

Third Edition



USAID
FROM THE AMERICAN PEOPLE

IUD Guidelines

for Family Planning Service Programs

Course Notebook for Trainers



JHPIEGO, an affiliate of The Johns Hopkins University, builds global and local partnerships to enhance the quality of health care services for women and families around the world. JHPIEGO is a global leader in the creation of innovative and effective approaches to developing human resources for health.

Copyright © 2006 by JHPIEGO. All rights reserved.

Published by:
JHPIEGO
Brown's Wharf
1615 Thames Street
Baltimore, Maryland 21231-3492, USA
<http://www.jhpiego.org>

The Capacity Project is an innovative global initiative funded by the United States Agency for International Development (USAID). The Capacity Project applies proven and promising approaches to improve the quality and use of priority health care services in developing countries by:

- Improving workforce planning and policy making;
- Developing better education and training systems for the workforce; and
- Strengthening systems to support workforce performance.

Led by IntraHealth International, the Capacity Project partnership includes: Emerging Markets Group, Ltd. (EMG); Interchurch Medical Assistance, Inc. (IMA); JHPIEGO; Liverpool Associates in Tropical Health (LATH); Management Sciences for Health (MSH); Program for Appropriate Technology in Health (PATH); and Training Resources Group, Inc. (TRG). <http://www.capacityproject.org>

Editors: Julia Bluestone
Rebecca Chase
Enriquito R. Lu

Editorial Assistance: Dana Lewison
Melissa McCormick

Graphic Assistance and Layout: Youngae Kim
Deborah Raynor

TRADEMARKS: All brand and product names are trademarks or registered trademarks of their respective companies.

This publication was completed for the Capacity Project through support provided by the United States Agency for International Development, under the terms of Award No. GPO-A-00-04-00026-00; and would not have been possible without initial support provided by Constella Futures (formerly Futures Group)/Key Social Marketing Pakistan Program, also through support provided by the U.S. Agency for International Development, under the terms of Award No. 391-A-00-0301017-00. The views expressed in this publication are those of JHPIEGO and do not necessarily reflect the views of the U.S. Agency for International Development or the United States Government.

June 2006

IUD COURSE NOTEBOOK FOR TRAINERS

SECTION ONE: GUIDE FOR PARTICIPANTS

OVERVIEW

Before Starting This Training Course	1
Training Approach	1
Key Features of Mastery Learning	2
Competency-Based Training	3
Components of the IUD Training Package	5
Using the IUD Training Package	5

INTRODUCTION

Course Design	7
Evaluation	8
Course Syllabus	9
Model IUD Course Schedule	13

INSTRUCTIONS FOR USING ZOE® GYNECOLOGIC SIMULATORS

Contents of the Original ZOE Model	15
Assembly of the Original ZOE Model	16
Procedures with All ZOE Models	18
Care and Maintenance of All ZOE Models	19

PRECOURSE QUESTIONNAIRE

How the Results Will Be Used	20
Precourse Questionnaire/Answer Sheet	21
Individual and Group Assessment Matrix	23

EXERCISE: HOW PEOPLE LEARN

EXERCISE 1: WHO ELIGIBILITY CRITERIA.....

EXERCISE 2: COUNSELING IUD USERS.....

EXERCISE 3: INFECTION PREVENTION

EXERCISE 4: CLIENT ASSESSMENT

EXERCISE 5: IUD INSERTION AND REMOVAL.....

EXERCISE 6: QUIZ

LEARNING GUIDES AND PRACTICE CHECKLIST

Using the Learning Guides	37
Using the Practice Checklist.....	38
Learning Guide for IUD Counseling Skills	39
Learning Guide for IUD Clinical Skills (Adapted for the Regular Copper T 380A)	43

Learning Guide for IUD Clinical Skills (Adapted for the Safe Load Copper T 380A)	49
Learning Guide for IUD Clinical Skills (Adapted for the Multiload Cu375)	56
Practice Checklist for IUD Counseling and Clinical Skills (Adapted for the Regular Copper T 380A)	62
Practice Checklist for IUD Counseling and Clinical Skills (Adapted for the Safe Load Copper T 380A)	65
Practice Checklist for IUD Counseling and Clinical Skills (Adapted for the Multiload Cu375)	68
COURSE EVALUATION	71
(Completed by participant)	

PRESENTATION GRAPHICS HANDOUTS

Intrauterine Contraceptive Devices (IUDs): Introduction	
Intrauterine Contraceptive Devices (IUDs): Education and Counseling	
Intrauterine Contraceptive Devices (IUDs): Infection Prevention	
Intrauterine Contraceptive Devices (IUDs): Client Assessment	
Intrauterine Contraceptive Devices (IUDs): Insertion and Removal	
Intrauterine Contraceptive Devices (IUDs): Follow-up Care and Management of Potential Problems	

SECTION TWO: GUIDE FOR TRAINERS

MODEL COURSE OUTLINE	1
PRECOURSE QUESTIONNAIRE	
Using the Individual and Group Assessment Matrix.....	12
Precourse Questionnaire Answer Key.....	13
EXERCISE: HOW PEOPLE LEARN	
Session Objective.....	15
Enabling Objectives.....	15
Comparison of Formal (School) and Practical (Hands-On) Methods of Learning	15
Stages of Learning Clinical Skills	18
Summary	19
Activity 1: Loading the TCu 380A IUD in a Sterile Package or Building a Paper Box	21
Activity 2: The Number Game	28
Activity 3: The Nine Dots Puzzle	37
PRECOURSE ASSESSMENT CHECKLIST	
Using the Checklist.....	40
Precourse Assessment Checklist for IUD Counseling and Clinical Skills.....	41
EXERCISE: WHO HAS AIDS?	43
EXERCISE 1 KEY: WHO ELIGIBILITY CRITERIA	44
EXERCISE 2 KEY: COUNSELING IUD USERS	46

EXERCISE 3 KEY: INFECTION PREVENTION	47
EXERCISE 4 KEY: CLIENT ASSESSMENT	48
EXERCISE 5 KEY: IUD INSERTION AND REMOVAL	50
EXERCISE 6 KEY: QUIZ	51
MIDCOURSE QUESTIONNAIRE	
Using the Questionnaire	53
Midcourse Questionnaire.....	54
Midcourse Questionnaire Answer Sheet	59
Midcourse Questionnaire Answer Key	61
CHECKLIST FOR IUD COUNSELING AND CLINICAL SKILLS	
Using the Checklist.....	65
Checklist for IUD Counseling and Clinical Skills (Adapted for the Regular Copper T 380A)	67
Checklist for IUD Counseling and Clinical Skills (Adapted for the Safe Load Copper T 380A)	70
Checklist for IUD Counseling and Clinical Skills (Adapted for the Multiload Cu375)	73
SECTION THREE: TIPS FOR TRAINERS	
BEING AN EFFECTIVE CLINICAL TRAINER	
Characteristics of an Effective Trainer and Coach	1
Skill Transfer and Assessment: The Coaching Process.....	2
CREATING A POSITIVE LEARNING ENVIRONMENT	
Preparing for the Course	4
Understanding How People Learn.....	6
Using Effective Presentation Skills	9
CONDUCTING LEARNING ACTIVITIES	
Delivering Interactive Presentations	11
Facilitating Group Discussions	14
Facilitating a Brainstorming Session	16
Facilitating Small Group Activities	17
Conducting an Effective Clinical Demonstration.....	19
TEACHING CLINICAL DECISION-MAKING	21
MANAGING CLINICAL PRACTICE	
Performing Clinical Procedures with Clients.....	24
Creating Opportunities for Learning	25
Conducting Pre- and Post-Clinical Practice Meetings	27
The Trainer as Supervisor	29
The Trainer as Coach.....	30

SECTION FOUR: SUPPLEMENTAL INFORMATION

THE MULTILOAD CU375: FREQUENTLY ASKED QUESTIONS	1
ANATOMY OF MULTILOAD CU375 ASSEMBLY AND PACKAGING	3
INSTRUCTIONS FOR INSERTING AND REMOVING THE MULTILOAD CU375	
Inserting Multiload	5
Removing Multiload	7
LEARNING GUIDE FOR IUD CLINICAL SKILLS	
(Adapted for the Multiload CU375)	9
CHECKLIST for IUD Counseling and Clinical Skills	
(Adapted for the Multiload Cu375)	15
MIRENA®: Frequently Asked Questions	19

OVERVIEW

BEFORE STARTING THIS TRAINING COURSE

This training course will be conducted in a way that is very different from traditional training courses. First of all, it is based on the assumption that people participate in training courses because they:

- Are **interested** in the topic
- Wish to **improve** their knowledge or skills, and thus their job performance
- Desire to be **actively involved** in course activities

The training approach used in this course stresses the importance of the cost-effective use of resources and application of relevant educational technologies including use of humane training techniques. The latter encompasses the use of anatomic models, such as the ZOE[®], to minimize client risk and facilitate learning.

TRAINING APPROACH

The **mastery learning** approach to clinical training assumes that all participants can master (learn) the required knowledge, attitudes, or skills provided sufficient time is allowed and appropriate training methods are used. The goal of mastery learning is that 100 percent of those being trained will “master” the knowledge and skills on which the training is based.

While some participants are able to acquire new knowledge or a new skill immediately, others may require additional time or alternative learning methods before they are able to demonstrate mastery. Not only do people vary in their abilities to absorb new material, but individuals learn best in different ways—through written, spoken, or visual means. Mastery learning takes these differences into account and uses a variety of teaching and training methods.

The mastery learning approach also enables the participant to have a self-directed learning experience. This is achieved by having the clinical trainer serve as facilitator and by changing the concept of testing and how test results are used. In courses that use traditional testing methods, the trainer administers pre- and post-tests to document an increase in the participants' knowledge, often without regard for how this change affects job performance.

By contrast, the philosophy underlying the mastery learning approach is one of a continual assessment of participant learning. With this approach, it is essential that the clinical trainer regularly inform participants of their progress in learning new information and skills, and **not** allow this to remain the trainer's secret.

With the mastery learning approach, assessment of learning is:

- **Competency-based**, which means assessment is keyed to the course objectives and emphasizes acquiring the essential knowledge, attitudinal concepts, and skills needed to perform a job, not simply acquiring new knowledge.
- **Dynamic**, because it enables clinical trainers to provide participants with continual feedback on how successful they are in meeting the course objectives and, when appropriate, to adapt the course to meet learning needs.
- **Less stressful**, because from the outset participants, both individually and as a group, know what they are expected to learn and where to find the information, and have ample opportunity for discussion with the clinical trainer.

KEY FEATURES OF MASTERY LEARNING

Effective clinical training is designed and conducted according to **adult learning principles**—learning is participatory, relevant, and practical—and:

- Uses **behavior modeling**
- Is **competency-based**
- Incorporates **humanistic training techniques**

Behavior Modeling

Social learning theory states that when conditions are ideal, a person learns most rapidly and effectively from watching someone perform (model) a skill or activity. For modeling to be successful, the trainer must clearly demonstrate the skill or activity so that participants have a clear picture of the performance expected of them.

Learning to perform a skill takes place in three stages. In the first stage, **skill acquisition**, the participant sees others perform the procedure and acquires a mental picture of the required steps. Once the mental image is acquired, the participant attempts to perform the procedure, usually with supervision. Next, the participant practices until **skill competency** is achieved and the individual feels **confident** performing the procedure. The final stage, **skill proficiency**, occurs only with repeated practice over time.

Skill Acquisition	Knows the steps and their sequence (if necessary) to perform the required skill or activity but needs assistance
Skill Competency	Knows the steps and their sequence (if necessary) and can perform the required skill or activity
Skill Proficiency	Knows the steps and their sequence (if necessary) and efficiently performs the required skill or activity

COMPETENCY-BASED TRAINING

Competency-based training (CBT) is distinctly different from traditional educational processes. Competency-based training is learning by **doing**. It focuses on the specific knowledge, attitudes, and skills needed to carry out a procedure or activity. How the participant performs (i.e., a combination of knowledge, attitudes, and, most important, skills) is emphasized rather than just what information the participant has acquired. Moreover, CBT requires that the clinical trainer facilitate and encourage learning rather than serve in the more traditional role of instructor or lecturer. Competency in the new skill or activity is assessed objectively by evaluating overall performance.

For CBT to occur, the clinical skill or activity to be taught first must be broken down into its essential steps. Each step is then analyzed to determine the most efficient and safe way to perform and learn it. This process is called **standardization**. Once a procedure, such as intrauterine contraceptive device (IUD) insertion, has been standardized, competency-based skill development (learning guides) and assessment (checklists) instruments can be designed. These instruments make learning the necessary steps or tasks easier and evaluating the participant's performance more objective.

An essential component of CBT is **coaching**, which uses positive feedback, active listening, questioning, and problem-solving skills to encourage a positive learning climate. To use coaching, the clinical trainer should first explain the skill or activity and then demonstrate it using an anatomic model or other training aid such as a video. Once the procedure has been demonstrated and discussed, the trainer/coach then observes and interacts with the participant to provide guidance in learning the skill or activity, monitors progress and helps the participant overcome problems.

The coaching process ensures that the participant receives **feedback** regarding performance:

- **Before practice**—The clinical trainer and participant should meet briefly before each practice session to review the skill/activity, including the steps/tasks that will be emphasized during the session.
- **During practice**—The clinical trainer observes, coaches, and provides feedback as the participant performs the steps/tasks outlined in the learning guide.
- **After practice**—This feedback session should take place immediately after practice. Using the learning guide, the clinical trainer discusses the strengths of the participant’s performance and also offers specific suggestions for improvement.

Humanistic Training Techniques

The use of more humane (humanistic) techniques also contributes to better clinical training. A major component of humanistic training is the use of anatomic models, which closely simulate the human body, and other learning aids such as videos. The effective use of models facilitates learning, shortens training time, and minimizes risks to clients. For example, by using anatomic models initially, participants more easily reach the performance levels of skill competency and beginning skill proficiency before they begin working in the clinic setting with clients.

Before a participant attempts a clinical procedure with a client, two learning activities should occur:

- The clinical trainer should demonstrate the required skills and client interactions several times using an anatomic model and appropriate audiovisual aids (e.g., video).
- While being supervised, the participant should practice the required skills and client interactions using the model and actual instruments in a simulated setting that is as similar as possible to the real situation.

Only when **skill competency** and some degree of **skill proficiency** have been demonstrated with models, however, should participants have their first contacts with clients.

When mastery learning, which is based on adult learning principles and behavior modeling, is integrated with CBT, the result is a powerful and extremely effective method for providing clinical training. And when humanistic training techniques, such as using anatomic models and other learning aids, are incorporated, training time and costs can be reduced significantly.

COMPONENTS OF THE IUD TRAINING PACKAGE

This course is built around use of the following components:

- Need-to-know information contained in a **reference manual**
- A **course handbook** containing validated questionnaires and learning guides, which break down the skill or activity (e.g., classroom presentation or clinical demonstration) into its essential steps
- A **trainer’s notebook**, which includes questionnaire answer keys and detailed information for conducting the course
- **Well-designed teaching aids and audiovisual materials**, such as videos, anatomic models, and other training aids
- **Competency-based performance evaluation**

The reference manual recommended for use in this course is *IUD Guidelines for Family Planning Service Programs: A Problem-Solving Reference Manual, Third Edition*, which contains practical “how-to” information and techniques to help the clinical trainer conduct participatory, humanistic IUD skills training courses.

USING THE IUD TRAINING PACKAGE

In designing the training materials for this course, particular attention has been paid to making them user-friendly and to permit the course participants and clinical trainer to easily adapt the training to the participants’ (group and individual) learning needs. For example, at the beginning of each course, an assessment is made of each participant’s knowledge. The results of this precourse assessment are then used jointly by the participants and the advanced or master trainer to adapt the course content as needed so that the training focuses on acquisition of **new** information and skills.

A second feature relates to the use of the reference manual and course handbook. The **reference manual** is designed to provide all of the essential information needed to conduct the course in a logical manner. Because it serves as the “text” for the participants and the “reference source” for the trainer, special handouts or supplemental materials are not needed. In addition, because the manual contains **only** information that is consistent with the course goals and objectives, it becomes an integral part of all classroom exercises, such as giving an illustrated lecture or providing problem-solving information.

The **course handbook**, on the other hand, serves a dual function. First, and foremost, it is the road map that guides the participant through each phase of the course. It contains the course syllabus and course schedule, as well as all supplemental printed materials (precourse questionnaire, individual and group assessment matrix, learning guides and course evaluation) needed during the course.

The **trainer's notebook** contains the same material as the course handbook for participants as well as material for the trainer. This includes the course outline, precourse questionnaire answer key, midcourse questionnaire and answer key, and competency-based qualification checklists.

In keeping with the training philosophy on which this course is based, all training activities will be conducted in an interactive, participatory manner. To accomplish this requires that the role of the trainer continually change throughout the course. For example, the trainer is an **instructor** when presenting a classroom demonstration; a **facilitator** when conducting small group discussions or using role plays; and shifts to the role of **coach** when helping participants practice a procedure. Finally, when objectively assessing performance, the trainer serves as an **evaluator**.

In summary, the CBT approach used in this course incorporates a number of key features. **First**, it is based on adult learning principles, which means that it is interactive, relevant, and practical. Moreover, it requires that the trainer facilitate the learning experience rather than serve in the more traditional role of an instructor or lecturer. **Second**, it involves use of behavior modeling to facilitate learning a standardized way of performing a skill or activity. **Third**, it is competency-based. This means that evaluation is based on **how well** the participant performs the procedure or activity, not just on **how much** has been learned. **Fourth**, where possible, it relies heavily on the use of anatomic models and other training aids (i.e., it is humanistic) to enable participants to practice repeatedly the standardized way of performing the skill or activity **before** working with clients. Thus, by the time the trainer evaluates each participant's performance using the checklist, **every** participant should be able to perform **every** skill or activity competently. **This is the ultimate measure of training.**

INTRODUCTION

COURSE DESIGN

This clinical training course is designed for service providers (physicians, nurses, and midwives). The course builds on each participant's past knowledge and experience and takes advantage of the individual's high motivation to accomplish the learning tasks in the minimum time. Training emphasizes **doing**, not just knowing, and uses **competency-based evaluation** of performance.

This training course differs from traditional courses in several ways:

- During the morning of the first day of the course, participants are introduced to the key features of mastery learning and then are briefly tested (**Precourse Questionnaire**) to determine their individual and group knowledge of the management of IUD services.
- Classroom and clinic sessions focus on key aspects of service delivery (e.g., counseling of clients, how to provide services, and manage side effects and other potential problems).
- Progress in knowledge-based learning is measured during the course using a standardized written assessment (**Midcourse Questionnaire**).
- Clinical skills training builds on the participant's previously mastered skills. Participants first practice on the anatomic models using learning guides that list the key steps in insertion and removal of IUDs. In this way, they learn more quickly the skills needed to insert and remove IUDs with clients in a standardized way.
- Progress in learning new skills is documented using the counseling and clinical skills learning guides.
- Evaluation of each participant's performance is conducted by a clinical trainer using competency-based skills checklists.

Successful completion of the course is based on mastery of both the content and skills components, as well as satisfactory overall performance in providing IUD services to clients.

IUD service delivery is a team effort, requiring the knowledge and skills of trained clinicians (physicians, nurses, or midwives) and other types of health professionals, such as counselors. Although this course is designed for a single health professional, it is easily adapted for training teams of two people (a clinician and a non-clinician, such as a counselor or health assistant) in all aspects of IUD service provision.

The person who actually performs the counseling or inserts the IUD may vary from country to country, depending on national and programmatic policies. Thus, opportunities are provided for learning and practicing IUD insertion and removal, as well as counseling techniques, infection prevention, record keeping and follow-up of clients. Even if a participant will not carry out a specific task, s/he needs to be familiar with it in order to ensure high-quality service delivery. Therefore, **all course participants** should be provided the opportunity to observe or perform all of the skills/activities associated with the safe delivery of IUD services.

EVALUATION

This clinical training course is designed to produce qualified IUD service providers. Qualification is a statement by the training organization that the participant has met the requirements of the course in knowledge, skills, and practice. Qualification does **not** imply certification. Personnel can be certified only by an authorized organization or agency.

Qualification is based on the participant's achievement in three areas:

- **Knowledge:** A score of at least 85% on the **Midcourse Questionnaire**
- **Skills:** Satisfactory performance of IUD counseling and clinical skills
- **Practice:** Demonstrated ability to provide IUD services in the clinical setting

Responsibility for the participant's becoming qualified is shared by the participant and the trainer.

The evaluation methods used in the course are described briefly below:

- **Midcourse Questionnaire.** This knowledge assessment will be given at the time in the course when all subject areas have been presented. A score of 85% or more correct indicates knowledge-based mastery of the material presented in the reference manual. For those scoring less than 85% on their first attempt, the clinical trainer should review the results with the participant individually and provide guidance on using the reference manual to learn the required information. Participants scoring less than 85% can take the Midcourse Questionnaire again at any time during the remainder of the course.
- **Provision of Services (Practice).** During the course, it is the clinical trainer's responsibility to observe each participant's overall performance in providing IUD services. This provides a key opportunity to observe the impact on clients of the participant's

attitude, a critical component of high-quality service delivery. Only by doing this can the clinical trainer assess the way the participant uses what s/he has learned.

- **Counseling and Clinical Skills Checklists.** The clinical trainer will use these checklists to evaluate each participant as s/he counsels clients and inserts or removes IUDs with clients. Evaluation of the **counseling skills** of each participant may be done with clients; however, it may be accomplished at any time during the course through observation during role plays using participants or volunteers. Evaluation of the **clinical skills** usually will be done during the last 2 days of the course (depending on class size and client caseload).

In determining whether the participant is qualified, the clinical trainer(s) will observe and rate the participant's performance for each step of the skill or activity. The participant must be rated satisfactory in each skill or activity to be evaluated as qualified.

It is recommended that, within 3 to 6 months of qualification, graduates be observed and evaluated working in their institution by a course trainer using the same counseling and clinical skills checklist. (At the very least, the graduate should be observed by a skilled provider soon after completing training.) This postcourse evaluation is important for several reasons. First, it not only gives the graduate direct feedback on her/his performance, but also provides the opportunity to discuss any startup problems or constraints to service delivery (e.g., lack of instruments, supplies or support staff). Second, and equally important, it provides the training center, via the clinical trainer, key information on the adequacy of the training and its appropriateness to local conditions. Without this type of feedback, training easily can become routine, stagnant and irrelevant to service delivery needs.

COURSE SYLLABUS

Course Description. This 6-day clinical training course is designed to prepare the participant to counsel individuals concerning the use of IUDs as a contraceptive method and to become competent in inserting and removing the Copper T 380A IUD (regular and/or with Safe Load) and in managing side effects and other potential problems associated with the use of IUDs.

Course Goals

- To influence in a positive way the attitudes of the participant toward the benefits and appropriate use of IUDs
- To provide the latest technical information on IUDs, including the most up-to-date WHO medical eligibility criteria (MEC)

- To provide the participant with information on general family planning counseling, as well as training in method-specific counseling for IUDs
- To provide the participant with the knowledge and skills necessary to use the appropriate infection prevention practices when providing IUD services
- To provide the participant with the knowledge and skills necessary to conduct an assessment of potential IUD users
- To provide the participant with the knowledge and skills needed for IUD insertion and removal
- To provide the participant with the knowledge and skills needed to provide routine follow-up care, and manage side effects and potential problems related to IUD use
- To provide the participant with the knowledge and skills needed to organize and manage quality IUD services

Participant Learning Objectives

By the end of the training course, the participant will be able to:

1. Explain how copper-bearing IUDs prevent pregnancy, their basic attributes, and their health benefits and risks, as well as most common side effects.
2. Address common misconceptions about the IUD.
3. Explain the WHO MEC for copper-bearing IUDs, as well as precautions and contraindications to IUD use.
4. Counsel a client interested in using a copper-bearing IUD.
5. Use recommended infection prevention practices to minimize the risk of postinsertion/postremoval infections and transmission of serious diseases (e.g., hepatitis B, HIV) to patients, clients, and health care staff.
6. Perform an assessment for potential IUD users, including a targeted history and physical examination (including a complete pelvic examination).
7. Load the Copper T (regular or with Safe Load) in its sterile package without using high-level disinfected (or sterile) gloves.
8. Insert the IUD gently and safely, using the “no-touch” technique.
9. Provide appropriate client education/counseling following IUD insertion (e.g., about when the IUD should be removed/replaced, side effects, the use of condoms to protect against sexually transmitted infections, warning signs, when to return to the clinic).
10. Explain the indications for IUD removal.

11. Remove an IUD gently and safely, using the using the “no-touch” technique.
12. Provide routine follow-up support to IUD users, as well as appropriate management of side effects and other potential problems.

Training/Learning Methods

- Illustrated lectures and group discussions
- Individual and group exercises
- Role plays
- Simulated practice with anatomic (pelvic) models
- Guided clinical activities (counseling and IUD insertion and removal)

Learning Materials. This course handbook is designed to be used with the following materials:

- Reference manual: *IUD Guidelines for Family Planning Service Programs: A Problem-Solving Reference Manual* (JHPIEGO)
- Infection prevention videos: *Infection Prevention Guidelines for Healthcare Facilities with Limited Resources: Overview and Practical Training Demonstration Segments* and *Safe Practices in the Operating Room*
- IUD insertion and removal kits, and Copper T IUDs in sterile packages
- Pelvic and hand-held uterine models for both types of IUDs

Participant Selection Criteria

Participants for this course should be clinicians (physicians, nurses, or midwives) working in a health care facility (clinic or hospital) that provides women’s health services.

Methods of Evaluation

Participant

- Pre- and Midcourse Questionnaires
- Learning Guides and Practice Checklist for IUD Counseling and Clinical Skills
- Checklist for IUD Counseling and Clinical Skills (to be completed by clinical trainer)

Course

- Course Evaluation (to be completed by each participant)

Course Duration

- 6 days

Suggested Course Composition

- 10 health professionals (clinicians) or 5 teams¹
- 2 clinical trainers

¹ The course size will be limited by the available space (classroom and demonstration areas/rooms) at the training facility and the number of potential IUD clients per session at the clinical training site(s).

MODEL IUD COURSE SCHEDULE (STANDARD COURSE: 6 DAYS, 12 SESSIONS)

DAY 1	DAY 2	DAY 3
0830–1200	0830–1200	0830–1200
<p>OPENING</p> <ul style="list-style-type: none"> Welcome Participant expectations <p>Overview of course</p> <ul style="list-style-type: none"> Goals and objectives Review of course materials and schedule <p>Precourse Questionnaire—Identify individual and group learning needs.</p> <p>Lecture/Discussion—Introduction to copper-bearing IUDs</p> <p>Lecture/Demonstration—Family planning education and counseling</p>	<p>Overview of day’s scheduled activities and warmup exercise</p> <p>Tour of Clinic Facilities and Observation</p> <p>Presentation—Infection prevention (IP)</p> <p>Discussion—Counseling, IP practices and method provision observed</p> <p>Demonstration—From abdominal exam through IUD insertion and removal</p>	<p>Overview of day’s scheduled activities and warmup exercise</p> <p>Discussion and Presentation—Client assessment</p> <p>Clinic Practice—Provide counseling, IP, or IUD services in the clinic with supervision or in classroom practice.</p>
LUNCH	LUNCH	LUNCH
1330–1630	1330–1630	1330–1630
<p>Assessment—Assess current skills in stations</p> <p>Discussion—Use and care of anatomical models</p> <p>Review of the day’s activities</p>	<p>Demonstration and Practice—Loading the IUD in its sterile package</p> <p>Activity and Discussion—Review IP practices and discuss</p> <p>Classroom Practice—Divide into two groups to practice:</p> <ul style="list-style-type: none"> Counseling a client Pelvic exam and insertion/removal of the IUD using pelvic models <p>Review of the day’s activities</p>	<p>Clinical Conference</p> <p>Exercise/Discussion—Client assessment and screening</p> <p>Exercise and discussion—Insertion of the IUD</p> <p>Discussion—Assessing individual risk of STIs</p> <p>Review progress so far</p>
<p>Reading Assignment: Chapters 1–5 and FHI’s “Quick Reference” Chart (at end of the manual)</p>	<p>Reading Assignment: Chapter 6 and Appendices A–D</p>	<p>Reading Assignment: As needed</p>

MODEL IUD COURSE SCHEDULE (STANDARD COURSE: 6 DAYS, 12 SESSIONS)

DAY 4	DAY 5	DAY 6
0830–1200	0830–1200	0830-1200
<p>Overview of day’s scheduled activities and warmup exercise</p> <p>Clinic Practice—Provide counseling, IP, or IUD services in the clinic with supervision or in classroom practice.</p> <p>(Note: Participants assess each other’s performance using learning guides or practice checklist. Over the next few days, those who wish to be assessed in certain skills should let the trainer know, and trainers will assess their performance using the checklist.)</p>	<p>Overview of day’s scheduled activities and warmup exercise</p> <p>Clinic Practice/Assessment—Provide counseling, IP, or IUD services in the clinic with supervision or in classroom practice.</p>	<p>Overview of day’s scheduled activities and warmup exercise</p> <p>Clinic Practice/Assessment—Provide counseling, IP, or IUD services in the clinic with supervision or in classroom practice.</p>
LUNCH	LUNCH	LUNCH
1330–1630	1330–1630	1330-1630
<p>Clinical Conference</p> <p>Demonstration/Discussion: Review IP guidelines</p> <p>Demonstration and Practice—In a simulated clinical area, demonstrate and practice insertion of IUD.</p> <p>Review of the day’s activities</p>	<p>Midcourse Questionnaire</p> <p>Classroom Practice— In a simulated clinical area, demonstrate and practice pelvic exam and insertion of IUD.</p> <p>Discussion/Activity—Quality assurance for IUD services</p> <p>Review of the day’s activities</p>	<p>Clinical Conference</p> <p>Classroom Assessment—In a simulated clinical area, the trainer will evaluate insertion of IUD.</p> <p>Demonstration/Discussion—Managing lost strings</p> <p>COURSE EVALUATION</p> <p>CLOSING</p>
<p>Reading Assignment: As needed to prepare for the Midcourse Questionnaire</p>	<p>Reading Assignment: As needed</p>	

INSTRUCTIONS FOR USING ZOE® GYNECOLOGIC SIMULATORS

A ZOE Gynecologic Simulator is a model of a full-sized, adult female lower torso (abdomen and pelvis). It is a versatile training tool developed to assist health professionals to teach the processes and skills needed to perform many gynecologic procedures. ZOE models are ideal for demonstrating and practicing the following procedures:

- Bimanual pelvic examination including palpation of normal and pregnant uteri
- Vaginal speculum examination
- Visual recognition of normal cervixes and abnormal cervixes
- Uterine sounding
- IUD insertion and removal
- Diaphragm sizing and fitting
- Laparoscopic inspection and occlusion of fallopian tubes (Falope rings or other clips)
- Minilaparotomy (both interval and postpartum tubal occlusion)
- Treatment of incomplete abortion using manual vacuum aspiration (MVA)

CONTENTS OF THE ORIGINAL ZOE MODEL

There are several models of ZOE Gynecologic Simulators now available, including an interval model and postpartum kit, so specific parts and accessories will vary. The original ZOE Gynecological Simulator kit includes the following:

ITEM	QUANTITY
Normal ante- and retroverted uteri with clear tops, attachments for round and ovarian ligaments as well as fallopian tubes and normal patent cervical os for pelvic examination and IUD insertion	2
6–8 week uterus with dilated (open) cervical os, which allows passage of a 5 or 6 mm flexible cannula	1
10–12 week uterus with dilated (open) cervical os, which allows passage of a 10 or 12 mm flexible cannula	1
Postpartum uterus (20 week size) with attached fallopian tubes for practicing postpartum tubal occlusion by minilaparotomy	1
Cervices (not open) for use in visual recognition:	
● Normal cervix	1
● Cervix with proliferation of columnar epithelium (ectropion)	1
● Cervix with inclusion (nabothian) cyst and endocervical polyp	1
● Cervix with lesion (cancer)	1

ITEM	QUANTITY
Normal cervixes with open os for IUD insertion/removal	5
Cervixes for 6–8 week and 10–12 week uteri (2 of each size)	4
Normal tubal fimbriae and ovaries (2 of each)	4
Fallopian tubes for tubal occlusion	8
Simulated round and ovarian ligaments (set of 2 each)	4
Extra thin cervical locking rings	3
Flashlight with batteries	1
Soft nylon carrying bag	1

Outer Skin

The **outer skin of the model** is foam-backed in order to simulate the feel of the anterior pelvic wall. The entire outer skin is removable to allow the model to be used for demonstration purposes (e.g., performing IUD insertion).

The 3 cm incision (reinforced at each end) located just **below** the umbilicus can be used to insert a laparoscope to look at the uterus, round ligaments, ovaries and fallopian tubes and practice laparoscopic tubal occlusion. This incision also can be used for practicing postpartum tubal ligation by minilaparotomy.

The 3 cm incision located a few centimeters **above** the symphysis pubis is used for practicing interval minilaparotomy. This incision also is reinforced, which allows the skin to be retracted to facilitate demonstration of the minilaparotomy technique.

Cervixes

The **normal** cervixes have a centrally located, oval-shaped os, which permits insertion of a uterine sound, uterine elevator or IUD. The **abnormal** cervixes are not open and can be used for demonstration only.

Each of the cervixes for treatment of incomplete abortion has a centrally located, oval-shaped os, which is dilated to allow passage of a 5 or 6 mm or 10 or 12 mm flexible cannula, respectively.

The normal cervixes and interchangeable uteri feature the patented “screw” design for fast and easy changing.

ASSEMBLY OF THE ORIGINAL ZOE MODEL

To use the original ZOE pelvic model for demonstrations or initially to learn how to change the parts (e.g., cervixes and uteri), you need to know how to remove the skin.

Removing and Replacing the Detachable Skin and Foam Backing

1. First, carefully remove the outer skin and its foam lining away from the rigid base at the “top” end of the model. (“Top” refers to the portion of ZOE nearest to the metal carrying handle located above the umbilicus.)
2. Lift the skin and foam up and over the legs, one leg at a time.
3. *Be as gentle as possible.* The detachable skin is made of material that approximates skin texture and it *can* tear.
4. If you wish to change the anteverted uterus and normal cervix that are shipped attached to ZOE, first you must remove the uterus.
5. Start by pulling the round ligaments away from the wall.
6. Then grasp the uterus while turning the *wide* grey ring counterclockwise until the cervix and uterine body are separated.
7. To remove the *cervix*, turn the *thin* grey ring counterclockwise until it comes off.
8. You then can push the cervix out through the vagina.
9. To **reassemble**, simply reverse this process.
10. To replace the skin and foam lining, start by pulling them down over the legs.
11. Then make sure the rectal opening is aligned with the opening in the rigid base.
12. Pull the skin and foam over the top of the model.
13. Finally, make sure both are pulled firmly down around the rigid base, and the skin is smoothly fitted over the foam.

Once you understand how ZOE’s anatomic parts fit together, we suggest you change them through the opening at the top of the model. This helps to preserve ZOE’s outer shell as you will only have to remove it for demonstrations or to change the postpartum (20 week size) uterus.

The anteverted and retroverted uteri have transparent top halves and opaque lower halves for use in demonstrating IUD insertion. These uteri are supported by round ligaments attached to the pelvic wall. The round ligaments, ovaries and fallopian tubes are removable.

To **remove the uterus:**

- Unscrew the wide locking ring attached to the uterus using a counterclockwise rotation.

To **remove the cervix**:

- Unscrew the thin locking ring immediately outside the apex of the vagina.
- The cervix should be pushed through the vagina and removed from the introitus.

To **reassemble**, proceed in reverse order.

PROCEDURES WITH ALL ZOE MODELS

Speculum examination:

- Use a medium bivalve speculum.
- Prior to inserting the speculum, dip it into clean water containing a small amount of soap. (This makes inserting the speculum easier.)
- To see the cervix, fully insert the speculum, angle it posteriorly (as in the human, the vagina in the ZOE model is angled posteriorly), then open the blades fully.
- To increase the diameter of the opening, use the speculum thumb screw (Pederson or Graves specula).

Passing instruments (uterine sound, uterine elevator, dilator or cannula) through the cervical os:

- Apply a small amount of clean water containing a drop or two of soap solution to the cervix (just as you would apply it with antiseptic solution in a client). This will make passing the instrument through the cervical os easier.

Sounding the uterus, inserting an IUD and interval minilaparotomy or laparoscopy:

- Use either the normal (nonpregnant) anteverted or retroverted uterus with a cervix having a patent os.

Postpartum minilaparotomy (tubal occlusion):

- Use the postpartum uterus (20 week size) with a cervix having a patent os.

Treatment of incomplete abortion using MVA:

- Use either the 6 to 8 or 10 to 12 week uteri (incomplete abortion) with the appropriate size cervix.

CARE AND MAINTENANCE OF ALL ZOE MODELS

The specific model of ZOE Gynecological Simulator will vary, depending on the location of the training site and the procedures being performed, but the care and maintenance of these models are the same for all.

- ZOE is constructed of material that approximates skin texture. Therefore, in handling the model, use the same gentle techniques as you would in working with a client.
- To avoid tearing ZOE's skin when performing a pelvic exam, use a dilute soap solution to lubricate the instruments and your gloved fingers.
- Clean ZOE after every training session using a mild detergent solution; rinse with clean water.
- DO NOT write on ZOE with any type of marker or pen, as these marks may not wash off.
- DO NOT use alcohol, acetone or Betadine⁷ or any other antiseptic that contains iodine on ZOE. They will damage or stain the skin.
- Store ZOE in the carrying case and plastic bag provided with your kit.
- **DO NOT** wrap ZOE in other plastic bags, newspaper, plastic wrap or any other kinds of material, as these may discolor the skin.

PRECOURSE QUESTIONNAIRE

HOW THE RESULTS WILL BE USED

The main objective of the **Precourse Questionnaire** is to assist both the **clinical trainer** and the **participant** as they begin their work together in the course by assessing what the participants, individually and as a group, know about the course topic. Providing the results of the precourse assessment to the participants enables them to focus on their individual learning needs. In addition, the questions alert participants to the content that will be presented in the course. The questions are presented in the true-false format.

For the clinical trainer, the questionnaire results will identify particular topics that may need additional emphasis during the learning sessions. Conversely, for those categories in which 85% or more of participants answer the questions correctly, the clinical trainer may elect to use some of the allotted time for other purposes. For example, if the participants as a group did well (85% or more of the questions correct) in answering the questions in the category “Counseling” (Questions 4 through 8), the clinical trainer may elect to assign that section as homework rather than discussing these topics in class.

For the participants, the learning objective(s) related to each question and the corresponding section(s) in the reference manual are noted beside the answer column. To make the best use of limited course time, participants are encouraged to address their individual learning needs by studying the designated section(s).

PRECOURSE QUESTIONNAIRE

Instructions: In the spaced provided, print a capital **T** if the statement is **true** or a capital **F** if the statement is **false**.

OVERVIEW

- | | | |
|--|-------|--|
| 1. A good candidate for using an IUD is a woman who wants at least several years of contraception. | _____ | Participant Objective 1
(Chapter 1) |
| 2. The risk of pelvic inflammatory disease in IUD users is related to sexually transmitted infections, not the IUD itself. | _____ | Participant Objective 2
(Chapter 1) |
| 3. Women who have had an ectopic pregnancy in the past can use the IUD. | _____ | Participant Objective 3
(Chapter 1) |

COUNSELING

- | | | |
|--|-------|--|
| 4. The service provider is the person best qualified to choose a contraceptive method for a woman in good health. | _____ | Participant Objective 4
(Chapter 2) |
| 5. Women who are not in a mutually faithful relationship (i.e., either partner has more than one sexual partner) are at increased risk for STIs and should be urged use condoms, in addition to the IUD, for protection. | _____ | Participant Objective 4
(Chapter 2) |
| 6. Counseling about possible side effects and how to manage them increases continued contraceptive use. | _____ | Participant Objective 4
(Chapter 2) |
| 7. The provider should avoid discussing “rumors” the woman may have heard about the method. | _____ | Participant Objective 4
(Chapter 2) |
| 8. Clients should be counseled that after IUD insertion, heavy vaginal discharge often occurs, which requires frequent douching. | _____ | Participant Objective 4
(Chapter 2) |

INFECTION PREVENTION

- | | | |
|---|-------|--|
| 9. Surgical (metal) instruments that have been decontaminated and thoroughly cleaned can be sterilized by boiling them in water for 20 minutes. | _____ | Participant Objective 5
(Chapter 3) |
| 10. High-level disinfection of gloves can be done by steaming them for 20 minutes. | _____ | Participant Objective 5
(Chapter 3) |
| 11. Tarnished (discolored) IUDs still inside the undamaged, sealed package should be discarded because they are no longer sterile. | _____ | Participant Objective 5
(Chapter 3) |

12. To minimize the risk of staff contracting hepatitis B or HIV/AIDS during the cleaning process, instruments and gloves **first** should be soaked for 20 minutes in 8% formaldehyde solution. _____ Participant Objective 5 (Chapter 3)

CLIENT ASSESSMENT

13. The physical examination of a potential IUD client **must** include breast, abdominal, and pelvic (speculum and bimanual) examinations. _____ Participant Objective 6 (Chapter 4)
14. If a woman is found to have a retroverted (posterior) uterus, she cannot have an IUD inserted. _____ Participant Objective 6 (Chapter 4)
15. If a client has current purulent cervicitis, the IUD should not be inserted at this time. _____ Participant Objective 6 (Chapter 4)

IUD INSERTION AND REMOVAL

16. To correctly insert the IUD, you must wear high-level disinfected or sterile gloves. _____ Participant Objective 7 (Chapter 5)
17. IUDs can be inserted at any time during the menstrual cycle provided that the client is not pregnant. _____ Participant Objective 8 (Chapter 5)
18. Following insertion of the IUD, the woman should be advised to return to the clinic after her next period (3 to 6 weeks). _____ Participant Objective 9 (Chapter 5)
19. A woman should not have her IUD removed unless she is willing to start another method immediately. _____ Participant Objective 10 (Chapter 5)
20. The Copper T 380A IUD should be removed/replaced in 12 years. _____ Participant Objective 10 (Chapter 5)
21. Prophylactic antibiotics should be given for routine IUD removal. _____ Participant Objective 11 (Chapter 5)

FOLLOW-UP CARE/MANAGEMENT OF POTENTIAL PROBLEMS

22. If a woman becomes pregnant with an IUD in place, she is more likely to have increased vaginal discharge. _____ Participant Objective 12 (Chapter 6)
23. When a woman is undergoing evaluation/treatment for a medical condition, the IUD usually does not need to be removed. _____ Participant Objective 12 (Chapter 6)

IUD TRAINING COURSE: INDIVIDUAL AND GROUP ASSESSMENT MATRIX

Course: _____ Dates: _____ Clinical Trainer(s): _____

QUESTION NUMBER	CORRECT ANSWERS (PARTICIPANTS)																						CATEGORIES	
	1	2	3	4	5	6	7	8	9	10	11	12	13	14	15	16	17	18	19	20	21	22		
1																								OVERVIEW
2																								
3																								
4																								COUNSELING
5																								
6																								
7																								
8																								INFECTION PREVENTION
9																								
10																								
11																								
12																								CLIENT ASSESSMENT
13																								
14																								
15																								

QUESTION NUMBER	CORRECT ANSWERS (PARTICIPANTS)																						CATEGORIES
	1	2	3	4	5	6	7	8	9	10	11	12	13	14	15	16	17	18	19	20	21	22	
16																							IUD INSERTION AND REMOVAL
17																							
18																							
19																							
20																							
21																							
22																							FOLLOW-UP CARE/ MANAGEMENT OF POTENTIAL PROBLEMS
23																							

HOW PEOPLE LEARN²

After completing this session, the participant will be able to identify how adults learn skills and apply this to attain the session objective. The participant will:

- Compare formal (school) and practical (hands-on) methods of learning
 - List the three stages of learning clinical skills
 - Identify the principles of learning
-

COMPARISON OF FORMAL (SCHOOL) AND PRACTICAL (HANDS-ON) METHODS OF LEARNING

- Characteristics of formal (school) teaching:
 - Structured
 - Instructor acts as though s/he is “better” than the students (top down)
 - Information is usually theoretical
 - Little or no interaction or student involvement
 - Few questions by the students
- Characteristics of practical training (e.g., the way a wood carver would teach his children about carving):
 - Informal
 - Learning is fun (low stress)
 - Learn by doing (hands-on)
 - Participatory (trainer and student are partners)
 - Interactive (questions going both ways)

The practical method is more like **coaching** as opposed to school teaching. An example of where coaching is an appropriate training method is learning a skill such as IUD insertion or removal.

HOW PEOPLE LEARN

- Training must be **relevant**. Learning experiences should relate directly to the job responsibilities of the participants.
- People often bring a **high level of motivation** to training:
 - Desire to improve job performance
 - Desire to learn

² Adapted from: Sullivan R et al. 1995. *Clinical Training Skills for Reproductive Health Professionals*. JHPIEGO: Baltimore, MD.

- Desire to improve their life
- People **need involvement** during training. This can be accomplished by:
 - Allowing participants to provide input regarding schedules, activities, and other events
 - Using questioning and feedback
 - Using brainstorming and discussions
 - Providing hands-on work
 - Conducting group and individual projects
 - Setting up classroom activities or games
- People desire **variety**. Ways to provide this include:
 - Varying the schedule
 - Using a variety of audiovisual aids:
 - Writing boards
 - Flipcharts
 - Overhead transparencies
 - Slides
 - Videos
 - Anatomic models or real items (e.g., instruments)
 - Using a variety of teaching methods:
 - Illustrated lectures
 - Demonstrations
 - Small group activities
 - Group discussions
 - Role plays and case studies
 - Guest speakers
- People need **positive feedback**. Positive feedback is letting participants know how they are doing, and providing this information in a positive manner. The clinical trainer provides positive feedback when s/he uses one or more of the following:
 - Verbal praise either in front of other participants or individually.
 - Recognizing appropriate responses during questioning:
 - That's correct!
 - Good answer!
 - That was an excellent response!

- Acknowledging appropriate skills while coaching in a clinical setting:
 - Very good work!
 - I would like everyone to notice the incision that was just made. Ilka did an excellent job. All incisions should look like this one.
- Letting the participants know how they are progressing toward achieving the learning objectives.
- The clinical trainer must recognize that participants may come to training with a number of **personal concerns** such as a fear of:
 - Failure or embarrassment
 - Fitting in with the other participants
 - Getting along with the trainer
 - Understanding the content
 - Being able to perform the skills being taught

The clinical trainer must be aware of these concerns and begin the course with an opening exercise that allows all participants to get to know each other in a safe and positive climate.

- People prefer to be treated as individuals who have **unique and particular backgrounds, experiences, and learning needs**. The clinical trainer can ensure that participants feel like individuals by using one or more of the following methods:
 - Using participant names as often as possible
 - Involving all participants as often as possible
 - Treating participants with respect
 - Allowing participants to share information with others during classroom and clinical instruction

Participants need to maintain **high self-esteem** to deal with the demands of clinical training. Respect on the part of the clinical trainer, which includes avoiding negative feedback, is essential to maintaining participant confidence while learning.
- The clinical trainer must maintain participants' **high expectations** by:
 - Conducting a training course that adds, rather than subtracts, from the participant's self-esteem and sense of competence
 - Setting high expectations for her/himself and her/his fellow trainers
 - Allowing participants to get to know and respect the trainer
 - Understanding and recognizing the participant's career accomplishments

- All participants have **personal needs** during training. Timely breaks from instruction, the best possible ventilation, proper lighting, and an environment as free from distraction as possible reduce tension and create a positive atmosphere.

STAGES OF LEARNING CLINICAL SKILLS

- **Skill acquisition** represents the initial phase in learning a new clinical skill or activity. One or more practice sessions are needed for learning how to perform the required steps and the sequence (if necessary) in which they should be performed. Assistance and coaching are necessary to achieve correct performance of the skill or activity.
- **Skill competency** represents an intermediate phase in learning a new clinical skill or activity. The participant can perform the required steps in the proper sequence (if necessary) but may not progress from step to step efficiently.
- **Skill proficiency** represents the final phase in learning a new clinical skill or activity. The participant efficiently and precisely performs the steps in the proper sequence (if necessary).

PRINCIPLES OF LEARNING (KEYS TO SUCCESS)

- The most productive way of learning is by **doing**. **Repetition** is necessary for **proficiency**.
- The more **realistic** the content, the more productive the learning.
- Learning is:
 - Most productive when the participant is ready to learn (It is up to the clinical trainer to create a climate that will motivate participants.)
 - Most productive when it builds on what the participant already has experienced or knows
 - Easier when the participant knows what s/he is expected to learn
 - More fun when a variety of methods and teaching techniques are used

EXERCISE 1: WHO MEDICAL ELIGIBILITY CATEGORIES

1. Which two eligibility categories mean you may provide the method?
2. Which two eligibility categories mean you generally should not use or can't use the method?
3. Which WHO category means use of the method is generally **not** recommended, and you should only use it if no other method is available or acceptable?
4. A woman has diabetes. What is the WHO category of this condition for IUD use?
5. A woman comes to you and would like an IUD. She is HIV-infected, her CD4 count is 400, and she is clinically well. What is the WHO category of this condition?

Can you give this woman the IUD? Why or why not?

6. The same woman comes to see you several years later. Now she has AIDS, her CD4 count is 150, and she is not on antiretroviral therapy. What is the WHO category for this woman for **continuing** the IUD?

What would the WHO eligibility category be for the same situation for **insertion**, not continuation?

7. If a woman has AIDS but is on antiretroviral therapy and receiving clinical care, what is the WHO category for IUD **insertion**?

For **continuation**?

8. A woman who wants the IUD has a reddened vagina and complains of some irritation. On pelvic examination, there is no purulent discharge, and STIs have been ruled out by lab tests. You treat her for bacterial vaginosis. Can you insert the IUD on this visit? Why or why not?

9. List six of the WHO category 4 conditions for IUD insertion.

10. A woman has herpes. What is the WHO category of this condition for IUD use?

11. A woman is nulliparous and would like the IUD for several years of protection. What is the WHO category?

What additional information/counseling would you give her about nulliparity and the IUD?

12. A woman had PID several months ago, but she and her partner have been treated. Upon reexamination, you find nothing unusual and she currently has no known risk factors for STIs. Can you give this woman the IUD? Why or why not?

EXERCISE 2: COUNSELING IUD USERS

Here are some sample scenarios for use in counseling role plays. Participants should use their learning guides as well as any informational/educational brochures or leaflets during practice.

1. A woman comes in who is interested in using an IUD. Counsel her using the GATHER technique.
2. A woman comes in who wants long-term contraceptive protection. As you are counseling her using the GATHER technique, she tells you she is concerned that an IUD can become dislodged and travel into other parts of her body. Address her fears by showing her how the IUD works using a handheld model or picture.
3. A woman comes in who is interested in using an IUD. As you are counseling her using the GATHER technique, she tells you she is concerned about the IUD will affect existing menstrual bleeding problems (heavy, prolonged, painful). Address her fears.
4. A woman comes in seeking contraception. As you are counseling her using the GATHER technique, she tells you that she got gonorrhea from her husband last year and is worried about getting another infection from him. Counsel her as appropriate.

EXERCISE 3: INFECTION PREVENTION

1. Which is the most important of the standard precaution practices?
2. Which is the first step in instrument processing and what is its purpose?
3. What is the key difference between sterilization and high-level disinfection?
4. When inserting an IUD, the client should put on a clean gown—true or false?
5. List the two antiseptics that may be used to cleanse the cervix and vagina prior to IUD insertion or removal.
6. Why is it appropriate to use new/clean examination gloves, rather than high-level disinfected (or sterile) surgical gloves, when inserting an IUD?
7. Define the **no-touch** technique.
8. A tarnished IUD inside its intact, sterile package is contaminated and should not be used—true or false?

EXERCISE 4: CLIENT ASSESSMENT

1. During the menstrual history, the woman complains of heavy menstrual bleeding and cramping. What would be your concern about the IUD for this woman?
2. When gathering her general medical history, you should ask every potential IUD user about which three medical conditions?
3. During the reproductive history, the woman complains of purulent discharge. What are three possible diagnoses?
4. What are you checking for when palpating the abdomen during the physical examination?
5. What are two reasons that the bimanual examination is so important?
6. During the visual inspection of the cervix using a speculum, list three things you are looking for.
7. In what situation would you perform a rectovaginal examination?
8. A woman has purulent cervical discharge, what should you do?
9. You are preparing to insert an IUD. When you insert the speculum, you notice purulent discharge from the cervix. What do you do?

EXERCISE 5: IUD INSERTION AND REMOVAL

1. List five things you can do to prevent infection when inserting an IUD.
2. List the two antiseptics that are appropriate for cleansing the cervix or vagina.
3. You sound the uterus at 8 cm; to what distance do you set the depth-gauge before IUD insertion?
4. You are explaining common side effects to a woman who just had an IUD inserted. What three points do you want to be sure to address about menstrual changes?

EXERCISE 6 KEY: QUIZ

1. When should a woman return for her first scheduled follow-up visit?
2. When else should she return to the clinic?
3. List three questions to ask clients when they return the first time.
4. The manual lists seven potential problems that may occur with IUD users. Which one is the most common cause of IUD removal?
5. If a woman becomes pregnant with the IUD in place, there are two things that are very important to do as soon as possible. What are they?
6. A woman comes to you and has heavy bleeding and cramping with her periods. She is extremely unhappy. What can you do to help her?
7. What are three possible signs of uterine perforation during uterine sounding or IUD insertion?
8. A woman is concerned about uterine perforation and asks for details about incidence and usual side effects. What can you tell her?

9. What are some of the signs/symptoms that can indicate expulsion, other than missing strings?

10. A woman with an IUD who has a partner with multiple partners comes in complaining of mild abdominal pain and fever. She has no unusual discharge, but has cervical motion tenderness. What would you do and why?

LEARNING GUIDES AND PRACTICE CHECKLIST FOR IUD COUNSELING AND CLINICAL SKILLS

The Learning Guides and Practice Checklist for IUD Counseling and Clinical Skills contain the steps or tasks performed by the counselor and clinician when providing IUD services. These tasks correspond to the information presented in the manual *IUD Guidelines for Family Planning Service Programs: A Problem-Solving Reference Manual*, 3rd ed.

These tools are designed to help the participant learn the steps or tasks involved in:

- Counseling a potential family planning client
- Counseling a client requesting IUD insertion or removal
- Inserting and removing the Copper T 380A IUD (regular or with Safe Load)

There are two learning guides in this handbook:

- Learning Guide for IUD Counseling Skills
- Learning Guide for IUD Clinical Skills—two versions:
 - *Adapted for the Regular Copper T 380A*
 - *Adapted for the TCU 380A with Safe Load*

There is one practice checklist in this handbook:

- Practice Checklist for IUD Counseling and Clinical Skills—two versions:
 - *Adapted for the Regular Copper T 380A*
 - *Adapted for the TCU 380A with Safe Load*

USING THE LEARNING GUIDES

The Learning Guide for IUD Clinical Skills is designed to be used primarily during the early phases of learning (i.e., skill acquisition) when participants are practicing with the anatomic (pelvic) model. Therefore, it does not include the steps involved in pre- and postinsertion counseling of clients.

- The participant is not expected to perform all of the steps or tasks correctly the first time s/he practices them. Instead, the learning guides are intended to:
 - Assist the participant in learning the correct steps and sequence in which they should be performed (**skill acquisition**)
 - Measure progressive learning in small steps as the participant gains confidence and skill (**skill competency**)

Note: If IUD insertion/removal training is conducted only with clients instead of using pelvic models, the clinical skills learning guide should be supplemented with relevant portions of the Learning Guide for IUD Counseling Skills.

- The Learning Guide for IUD Counseling Skills should be used initially during practice (simulated) counseling sessions with volunteers or with clients in real situations.
- Initially, participants can use the learning guides to follow the steps as the clinical trainer role plays counseling a client or demonstrates IUD insertion or removal using a pelvic model.
- Subsequently, during the classroom practice sessions, they serve as step-by-step guides for the participant as s/he performs the skill using pelvic models, or counsels a volunteer “client.”

Because the learning guides are used to assist in developing skills, it is important that the rating (scoring) be done carefully and as objectively as possible. The participant’s performance of each step is rated on a three-point scale as follows:

1	Needs Improvement: Step or task not performed correctly or out of sequence (if necessary) or is omitted
2	Competently Performed: Step or task performed correctly in proper sequence (if necessary) but participant does not progress from step to step efficiently
3	Proficiently Performed: Step or task efficiently and precisely performed in the proper sequence (if necessary)

USING THE PRACTICE CHECKLIST

The Practice Checklist for IUD Counseling and Clinical Skills combines, and is derived from, both the counseling and clinical skills learning guides, but it focuses only on the key steps in the **entire** procedure.

- As the participant progresses through the course and gains experience, dependence on the detailed learning guides decreases and the practice checklist may be used in their place.
- The practice checklist can be used by participants, when providing services in a clinical situation, to rate one another’s performance
- The practice checklist is the same as the Checklist for IUD Counseling and Clinical Skills, which the clinical trainer will use to evaluate each participant’s performance at the end of the course.

Because the checklist is used to measure skills, it is important that the rating (scoring) be done carefully and as objectively as possible. The participant’s performance of each step is rated on a three-level scale as follows:

Satisfactory: Performs the step or task according to the standard procedure or guidelines
Unsatisfactory: Unable to perform the step or task according to the standard procedure or guidelines
Not Observed: Step, task or skill not performed by participant during evaluation by trainer

Remember: It is the goal of this training that **every** participant perform **every** task or activity correctly with clients by the end of the course.

LEARNING GUIDE FOR IUD COUNSELING SKILLS

(To be used by **Participants**)

Rate the performance of each step or task observed using the following rating scale:

- 1 Needs Improvement:** Step or task not performed correctly or out of sequence (if necessary) or is omitted
- 2 Competently Performed:** Step or task performed correctly in proper sequence (if necessary) but participant does not progress from step to step efficiently
- 3 Proficiently Performed:** Step or task efficiently and precisely performed in the proper sequence (if necessary)

LEARNING GUIDE FOR IUD COUNSELING SKILLS					
STEP/TASK	CASES				
GENERAL FAMILY PLANNING COUNSELING					
Greet the Woman					
1. Greet the client with warmth and respect, and thank her for coming.					
2. Ask why she has come, and what she hopes to get out of the visit.					
3. Explain your role: to assist her in choosing a contraceptive method.					
4. Encourage her to talk and to answer questions openly.					
5. Assure her that the meeting will be confidential.					
Ask the Woman about Herself					
6. Ask about previous experiences with family planning.					
7. Assess partner/family attitudes about family planning.					
8. Ask about her reproductive goals (how many children she wants, desire for birth spacing, desire for long-term protection, etc.).					
9. Ask about her need for protection against STIs (this will be further assessed later).					
10. Ask whether she is interested in a particular family planning method.					
Tell the Woman about Family Planning [Tip: Use support materials such as diagrams, brochures, and actual samples of methods to emphasize and illustrate points.]					
11. Provide general information about family planning, focusing on the method(s) in which she is interested and any other appropriate methods. Tailoring information to fit her individual needs and situation, explain the following attributes of the method(s): <ul style="list-style-type: none"> ● Effectiveness and effective life ● Mechanism of action ● Side effects ● Health benefits and potential risks ● Protection against HIV and other STIs ● Cost and convenience ● Accessibility/availability of supplies needed [Note: Keep in mind that many women may not be aware of the IUD or know anything about it.]					
12. Correct any misconceptions the woman may have about the method(s) she is considering. Ask whether she has any concerns about the method. Ask what she has heard about it. [Note: This may be especially important for potential IUD users, as misinformation about the IUD is prevalent in many parts of the world.]					

LEARNING GUIDE FOR IUD COUNSELING SKILLS					
STEP/TASK	CASES				
Help the Woman Select a Method					
13. Once the woman has selected a method, assess her knowledge about it by asking her questions about it, and having her repeat key information back to you.					
13a. Ensure that the potential IUD user understands that menstrual changes (increase in amount and duration of bleeding and pain/cramping) are a common side effect among IUD users, and: <ul style="list-style-type: none"> • Are the main reason women choose to discontinue the method • Are not usually harmful • Often lessen or go away within a few months • Can be reduced by use of NSAIDs. 					
13b. Ensure that the potential IUD user understands that the IUD does not protect against STIs, including HIV, and: <ul style="list-style-type: none"> • The IUD is not a good choice for women who have a very high individual risk of gonorrhea and chlamydia (this will be further assessed later). • Women who may be at risk for STIs should use a condom, in addition to the IUD, for protection every time they have sex. 					
14. Encourage her to ask questions and state any remaining concerns about the method selected. Provide additional information and reassurance as needed.					
15. Ensure that the woman understands any examinations or procedures required for provision of the method selected. [Potential IUD users should understand that a medical assessment including a pelvic examination is required to confirm a woman's eligibility for IUD use, and that IUD insertion and removal require minor procedures that must be performed by a skilled provider.]					
16. Once the appropriate assessment is completed to confirm that the woman is medically eligible to start the method, provide the method. [Potential IUD users should be provided an overview of the procedure before the IUD is inserted; this is expanded upon below in "Preinsertion Education/Counseling."]					
METHOD-SPECIFIC COUNSELING					
Explain How to Use the Method [Expanded upon below in "Postinsertion Education/Counseling"]					
1. Explain to the client how to use the method, as well as what to do if she experiences side effects, and provide any other basic information needed.					
2. Provide information on warning signs that indicate a need to return to the clinic immediately.					
3. Provide specific instructions on when to return to the clinic for follow-up.					
4. Have the woman repeat key messages for safe and effective use of the method.					
5. Encourage her to ask questions and state any remaining concerns about the method selected. Provide additional information and reassurance as needed.					
Return Visit/Refer					
6. Assess the woman's satisfaction with the method.					
7. Check for problems or concerns. [For IUD users during the first routine check-up, emphasis is on menstrual problems, use of condoms for protection against STIs as needed, PAINS, and checking for IUD expulsion.]					
8. Reinforce key messages for safe and effective use of the method. [For new IUD users during the first routine check-up, emphasis is on providing reassurance for menstrual problems, and reminding the woman about use of condoms for protection against STIs as needed, PAINS, and checking for IUD expulsion.]					
9. Refer the woman if needed.					

LEARNING GUIDE FOR IUD COUNSELING SKILLS					
STEP/TASK	CASES				
IUD INSERTION (COUNSELING)					
Preinsertion Education/Counseling					
1. Provide an overview of the procedure, explaining what it involves, how long it will take, etc.					
2. Explain that it is very safe.					
3. Tell her that she may experience some discomfort, but that you will try to make it as comfortable as possible; advise her to let you know if/when she feels pain.					
4. Ask if she has questions or concerns; provide additional information or reassurance as needed.					
[Note: Continue informing the woman of what you are doing throughout the procedure; alert her to possible discomfort before performing the step that may cause it. Immediately following the procedure, ask the client how she feels. (She should stay in clinic for the next 15 to 30 minutes.)]					
Postinsertion Education/Counseling (before the woman leaves the clinic)					
5. Reinforce basic facts about her IUD: <ul style="list-style-type: none"> Type of IUD [Copper T 380A] Course of protection [immediately effective; lasts for 12 years] Removal [any time for any reason, as long as performed by a skilled provider] 					
6. Remind client of need to use condoms in addition to the IUD if she is at risk for STIs.					
7. Review common side effects (menstrual changes) and what to do if they occur.					
8. Review warning signs that indicate a need to return to the clinic immediately: PAINS (Period late or heavy, Abdominal pain, Infection symptoms, Not feeling well, String changes or problems).					
9. Tell the woman how and when to check for IUD expulsion. <ul style="list-style-type: none"> Check for IUD strings after first few menses Check for IUD on pad, in latrine, etc., during first few menses 					
10. Inform the client when to return for the follow-up visit: <ul style="list-style-type: none"> After first postinsertion menses (3 to 6 weeks) for routine check-up If side effects become bothersome If PAINS occur (immediately) To have IUD removed Any other time for any reason 					
11. Have the woman repeat key messages for safe and effective use of the method.					
12. Encourage her to ask questions and state any remaining concerns about the method selected. Provide additional information and reassurance as needed.					
IUD REMOVAL (COUNSELING)					
1. Greet the woman with warmth and respect and thank her for coming.					
2. Establish the purpose of the visit.					
3. Ask the woman her reason for having the IUD removed. [Note: Appropriate counseling, assessment, and other aspects of care will depend in part on the reason for IUD removal.]					
4. Determine whether she will have another IUD inserted immediately, start a different method, or neither.					

LEARNING GUIDE FOR IUD COUNSELING SKILLS					
STEP/TASK	CASES				
5. Provide basic family planning counseling as needed: <ul style="list-style-type: none"> • Ensure that she understands that there is immediate return to fertility upon IUD removal. • Ask client about her reproductive goals (Does she want to continue spacing or limiting births?). • Ask about her need for protection against STIs. • Help her choose another contraceptive method if needed. 					
6. Before removing the IUD, provide a brief overview of the procedure, and: <ul style="list-style-type: none"> • Advise her to let you know if/when she feels pain. • Ask if she has any questions or concerns. • Provide additional information or reassurance as needed. 					
<p>[Note: Continue informing the woman of what you are doing throughout the procedure; alert her to possible discomfort before performing the step that may cause it. Immediately following the procedure, ask the client how she feels. (She should stay in clinic for the next 15 to 30 minutes.)]</p>					
7. If the woman has had a new IUD inserted, review key messages for IUD users. [If the woman is starting a different method, provide the information she needs to use it safely and effectively (and a back-up method, if needed).]					
8. Have the woman repeat key messages for safe and effective use of the method she is using.					
9. Encourage her to ask questions and state any remaining concerns about the method selected. Provide additional information and reassurance as needed.					

LEARNING GUIDE FOR IUD CLINICAL SKILLS

(ADAPTED FOR THE REGULAR COPPER T 380A)

(To be used by **Participants**)

Rate the performance of each step or task observing the following rating scale:

- 1 Needs Improvement:** Step or task not performed correctly or out of sequence (if necessary) or is omitted
- 2 Competently Performed:** Step or task performed correctly in proper sequence (if necessary) but participant does not progress from step to step efficiently
- 3 Proficiently Performed:** Step or task efficiently and precisely performed in the proper sequence (if necessary)

LEARNING GUIDE FOR IUD <i>CLINICAL SKILLS</i> (REGULAR COPPER T 380A)					
STEP/TASK	CASES				
IUD INSERTION					
Client Assessment					
1. Greet the client with kindness and respect.					
2. Determine that the client has been counseled about the IUD in general, as well about the insertion procedure.					
History					
3. Review the client's contraceptive, menstrual, and obstetric history to confirm that the IUD is an appropriate choice for the client, focusing especially on ensuring that the client is not pregnant . Ask about: <ul style="list-style-type: none"> ● Heavy, prolonged, or menstrual painful periods ● Parity/gravida ● Childbirth or abortion within the last 4 weeks; signs/symptoms of infection with either ● Possibility of pregnancy (delayed or missing period, unprotected sex since last menstrual period [LMP]) (Note: If needed, use checklist provided in Appendix B to be reasonably sure the client is not pregnant.)					
4. Review the client's pertinent (general and reproductive) medical history to confirm that the IUD is an appropriate choice for the client, focusing especially on ensuring that the client is not at high individual risk of sexually transmitted infections (STIs) . Ask about: <ul style="list-style-type: none"> ● Severe anemia ● HIV/AIDS ● Complicated valvular heart disease ● Cancer of the reproductive organs ● Trophoblastic disease ● Pelvic tuberculosis ● Unexplained vaginal bleeding ● High individual risk of STIs <ul style="list-style-type: none"> – STI within last 3 months (self or partner) – Multiple partners (self or partner) – Partner with symptoms of STI (e.g., penile discharge) ● Diagnosis of pelvic inflammatory disease (PID), gonorrhea, chlamydia, or other STIs (within last 3 months) ● Symptoms of PID, gonorrhea, chlamydia, or other STIs <ul style="list-style-type: none"> – Lower abdominal pain – Current unusual or purulent vaginal discharge 					
Physical Examination					
5. Ensure that a high-level disinfected (HLD) instrument pan (or sterile pack), supplies, and light source are available.					

LEARNING GUIDE FOR IUD <i>CLINICAL SKILLS</i> (REGULAR COPPER T 380A)					
STEP/TASK	CASES				
6. Have the client empty her bladder and wash and rinse her perineal area if possible.					
7. Help the client onto the examination table.					
8. Tell the client what is going to be done, and ask her if she has any questions.					
9. Wash your hands thoroughly with soap and water; and dry them with clean, dry cloth or allow them to air dry.					
10. Check for signs of anemia/severe anemia .					
11. Palpate the abdomen : <ul style="list-style-type: none"> ● Check for suprapubic tenderness. ● Check for swellings, bulges, masses, or other gross-abnormalities. 					
12. Drape the client appropriately for pelvic exam.					
13. Wash your hands <u>again</u> thoroughly with soap and water; and dry them with clean, dry cloth or allow them to air dry.					
14. Open the HLD instrument pan (or sterile pack) without touching instruments.					
15. Using an HLD (or sterile) pick-up forcep, arrange the instruments and supplies on an HLD pan (or sterile tray), being very careful not to touch parts of the instruments that will go into the vagina or uterus.					
16. Put new/clean examination or HLD (or sterile) surgical gloves on both hands.					
17. Inspect the external genitalia and urethral opening: <ul style="list-style-type: none"> ● Check for ulcers, lesions, and sores. ● Check for buboes (enlarged groin nodes). ● Palpate Skene's and Bartholin's glands, checking for tenderness or discharge. 					
Note: <ul style="list-style-type: none"> ● If findings are normal (findings that do not suggest possible infection or other pelvic problems), perform the bimanual exam first and the speculum exam second. This allows you to sound the uterus and insert the IUD without having to insert the speculum twice. ● If there are potential problems (findings that suggest possible infection or other pelvic problems), perform the speculum exam first and a bimanual exam second. 					
18a. Perform a bimanual exam (see Note above): <ul style="list-style-type: none"> ● Determine the size, shape, and position of uterus. ● Check for enlargement or tenderness of the adnexa and for cervical motion tenderness. ● Check for uterine abnormalities that may interfere with proper placement of the IUD. 					
18b. Perform rectovaginal exam only if: <ul style="list-style-type: none"> ● Position or size of uterus is unclear. ● There is a possible mass behind the uterus. 					
18c. If rectovaginal exam is performed, do the following before continuing: <ul style="list-style-type: none"> ● Immerse both gloved hands in 0.5% solution. ● Remove gloves by turning inside out and dispose of them ● Put on new/clean examination or HLD (or sterile) gloves. 					
19. Perform a speculum exam (see Note above) of the vagina and cervix (by gently spreading the labia with two fingers and then inserting the HLD [or sterile] speculum, starting obliquely and then rotating it to the horizontal position): <ul style="list-style-type: none"> ● Check for purulent vaginal discharge. ● Check for ulcers, lesions, and sores. ● Check cervix for purulent cervicitis, bleeding, erosions, or narrowing of the cervical canal (stenosis). (Note: If laboratory testing is indicated and available, refer to steps at the end of learning guide.)					

LEARNING GUIDE FOR IUD <i>CLINICAL SKILLS</i> (REGULAR COPPER T 380A)					
STEP/TASK	CASES				
Preinsertion and Insertion Steps					
1. If both bimanual and speculum exams are normal, give the client a brief overview of the insertion procedure, encourage her to ask questions, and provide reassurance if needed. Remind her to let you know if she feels any pain.					
Sounding the Uterus					
2. Gently insert the HLD (or sterile) speculum (if not already done; visualize cervix), and cleanse the cervical os and vaginal wall with an appropriate antiseptic two or more times.					
3. Gently grasp the cervix with an HLD (or sterile) tenaculum and apply gentle traction. Do not lock the tenaculum beyond the first notch, unless necessary.					
4. While gently pulling on the tenaculum, and without allowing the tip of the sound to touch the vaginal walls or the speculum blades, carefully insert the sound into the cervical os.					
5a. Gently advance the sound at the appropriate angle (based on bimanual exam).					
5b. STOP advancing the sound when a slight resistance is felt, and confirm the position of the uterus (anterior or posterior) for the IUD insertion. Do not use force at any stage of this procedure.					
6. Remove the sound. (Do not pass the sound into the uterus more than once.)					
7. Determine the depth of the uterus by noting the level of mucus or wetness on the sound.					
8. Place the sound in 0.5% chlorine solution for 10 minutes for decontamination.					
Loading the IUD in Its Sterile Package (Important: Do not load the IUD until the final decision to insert the IUD has been made.)					
9. Adjust the contents of the package (through the package) so that the “T” is fully inside insertion tube.					
10. Peel the clear plastic cover half-way to blue depth-gauge.					
11. Place the white plunger rod in the clear insertion tube.					
12. Bend the “arms” of the T downward: <ul style="list-style-type: none"> Place the package on a flat surface. Stabilize the arms of the T with one hand. Slide the measurement insert under the T with the other hand. Still holding the arms of the T, push the insertion tube toward the IUD to push the arms downward. (Important: Do not fold the arms of the T into the insertion tube more than 5 minutes before the IUD is inserted into the uterus.)					
13. When the arms of the T touch the sides of the insertion tube, pull the tube away from the folded arms of the IUD.					
14. Slightly elevate the insertion tube, and push and rotate it back over the tips of the arms of the IUD, so that both tips are caught inside the tube.					
15. Push the folded arms of the IUD into the tube only as far as needed to keep them fixed in the tube.					
16. With the loaded IUD still in the package, set the blue depth-gauge to the corresponding measurement obtained from sounding the uterus. <ul style="list-style-type: none"> Press down on the gauge with one hand to keep it stable. At the same time, slide the insertion tube with your other hand until the tip of the IUD aligns with the tip in the diagram on the measurement insert. 					
17. Align the blue depth-gauge and the folded arms of the T so that they are both in horizontal position (flat against the package on the table).					

LEARNING GUIDE FOR IUD <i>CLINICAL SKILLS</i> (REGULAR COPPER T 380A)					
STEP/TASK	CASES				
18. Finish peeling back the cover in one brisk, continuous movement with one hand, while holding the loaded IUD through the open end of the package against the white backing (on the table) with the other hand.					
19. Lift the loaded IUD from the package, without allowing it to touch anything that is not sterile. Keep it level so that the IUD does not fall out, and be careful not to push the white rod toward the IUD.					
Inserting the IUD					
20. Put new/clean examination or HLD (or sterile) surgical gloves on both hands (if taken off to load the IUD).					
21. Give the client a brief overview of the procedure, encourage her to ask questions, and provide reassurance if needed. Remind her to let you know if she feels any pain.					
22. Hold the IUD so that blue depth-gauge is in horizontal position. Gently grasp the tenaculum with the other hand and gently pull outward and downward.					
23a. Carefully insert the loaded IUD into the vaginal canal and gently push it through the cervical os and into uterine cavity at the appropriate angle (based on sounding).					
23b. Gently advance the loaded IUD into the uterine cavity until the blue depth-gauge comes into contact with the cervix or slight resistance is felt. (Important: Be careful not to touch the wall of vagina or the speculum blades with the tip of the loaded IUD. Do not use force at any stage of this procedure.)					
24. Hold the tenaculum and white rod stationary with one hand, and release the arms of the T from the insertion tube using the withdrawal technique: <ul style="list-style-type: none"> • Gently pull the insertion tube away from the IUD (while holding the white rod stable) until it touches the circular thumb grip of the white plunger rod. • Remove the white plunger rod, while holding the insertion tube stationary. 					
25. Gently push insertion tube upward again, toward the fundus of the uterus, until you feel a slight resistance.					
26. Partially withdraw the insertion tube from the cervical canal until the string can be seen extending from the cervical os.					
27. Use HLD (or sterile) sharp Mayo scissors to cut the IUD strings to 3–4 cm length.					
28. Gently remove the tenaculum and place in 0.5% chlorine solution for 10 minutes for decontamination.					
29. Examine the cervix. If there is bleeding where the tenaculum was attached to the cervix, use HLD (or sterile) forceps to place cotton (or gauze) swab on the affected tissue, and apply gentle pressure for 30–60 seconds.					
30. Gently remove speculum and place in 0.5% chlorine solution for 10 minutes for decontamination.					
31. Ask the client if she is experiencing nausea, mild to moderate lower abdominal pain/cramping, and dizziness or fainting. If she is experiencing any of these symptoms, provide reassurance and allow her remain on the examination table until she feels better (she should stay in clinic for at least 15 to 30 minutes). Begin performing the postinsertion steps.					
Postinsertion Steps					
1. Before removing the gloves, place all used instruments in 0.5% chlorine solution for 10 minutes for decontamination. (After the client has left, wipe the examination table with 0.5% chlorine solution.)					
2. Dispose of waste materials (e.g., cotton balls) by placing in a leak-proof container (with a tight-fitting lid) or plastic bag.					

LEARNING GUIDE FOR IUD <i>CLINICAL SKILLS</i> (REGULAR COPPER T 380A)					
STEP/TASK	CASES				
3. Immerse both gloved hands in 0.5% chlorine solution. Remove gloves by turning inside out: <ul style="list-style-type: none"> ● If disposing of gloves, place in the leak-proof container or plastic bag. ● If reusing surgical gloves (not recommended), submerge them in 0.5% chlorine solution for 10 minutes for decontamination. 					
4. Wash hands thoroughly with soap and water; and dry them with a clean, dry cloth or air dry.					
5. Provide postinsertion instructions (key messages for IUD users): <ul style="list-style-type: none"> ● Basic facts about her IUD (e.g., type, how long effective, when to replace/remove) ● No protection against STIs; need for condoms if at risk ● Possible side effects ● Warning signs (PAINS) ● Checking for possible IUD expulsion ● When to return to clinic 					
IUD REMOVAL					
Preremoval Steps					
1. Greet the woman with kindness and respect, and establish purpose of visit.					
2. Ask the woman her reason for having the IUD removed.					
3. Determine whether she will have another IUD inserted immediately, start a different method, or neither.					
4. Counsel as appropriate: <ul style="list-style-type: none"> ● Ensure that she understands that there is immediate return to fertility after IUD removal. ● Review the client's reproductive goals and need for STI protection ● Discuss other contraceptive methods if desired. 					
5. Ensure that a high-level disinfected (HLD) instrument pan (or sterile pack), supplies, and light source are available.					
6. Open the HLD instrument pan (or sterile pack) without touching instruments. Using an HLD (or sterile) pick-up forcep, arrange the instruments and supplies on an HLD pan (or sterile tray), being very careful not to touch parts of the instruments that will go into the vagina or uterus.					
7. Have the client empty her bladder and wash and rinse her perineal area if possible.					
8. Help the client onto the examination table.					
9. Wash your hands thoroughly with soap and water; and dry them with clean, dry cloth or allow them to air dry.					
10. Put new/clean examination or HLD (or sterile) surgical gloves on both hands.					
11. Give the client a brief overview of the procedure, encourage her to ask questions, and provide reassurance as needed. Remind her to let you know if she feels any pain.					
Removing the IUD					
1. Insert an HLD (or sterile) speculum to visualize the IUD strings.					
2. Cleanse the cervix (especially the os) and vagina with an appropriate antiseptic two or more times.					
3. Alert the client immediately before you remove the IUD. Ask her to take slow, deep breaths and inform her that she may feel some discomfort and cramping, which is normal.					
4. Grasp the IUD strings close to the cervix with an HLD (or sterile) hemostat or other narrow forceps.					

LEARNING GUIDE FOR IUD <i>CLINICAL SKILLS</i> (REGULAR COPPER T 380A)					
STEP/TASK	CASES				
5. Apply steady but gentle traction, pulling the strings toward you, to remove the IUD. Do not use excessive force.					
6. Show the IUD to client.					
7. Place the IUD in 0.5% chlorine solution for 10 minutes for decontamination.					
8. If the woman is having a new IUD inserted, insert it now if appropriate. If she is not having a new IUD inserted, gently remove the speculum and place it in 0.5% chlorine solution for 10 minutes for decontamination.					
9. Ask the client if she is experiencing nausea, mild to moderate lower abdominal pain/cramping, and dizziness or fainting. If she is experiencing any of these symptoms, provide reassurance and allow her remain on the examination table until she feels better (she should stay in clinic for at least 15 to 30 minutes).					
Postremoval Steps					
1. Before removing the gloves, place all used instruments in 0.5% chlorine solution for 10 minutes for decontamination. (After the client has left, wipe the examination table with 0.5% chlorine solution.)					
2. Dispose of waste materials (e.g., cotton balls) by placing in a leak-proof container (with a tight-fitting lid) or plastic bag.					
3. Immerse both gloved hands in 0.5% chlorine solution. Remove gloves by turning inside out: <ul style="list-style-type: none"> ● If disposing of gloves, place in the leak-proof container or plastic bag. ● If reusing surgical gloves (not recommended), submerge them in 0.5% chlorine solution for 10 minutes for decontamination. 					
4. Wash hands thoroughly with soap and water; and dry them with a clean, dry cloth or air dry.					
5. If the woman has had a new IUD inserted, review key messages for IUD users. [If the woman is starting a different method, provide the information she needs to use it safely and effectively (and a back-up method, if needed).]					
*Laboratory Testing (if available and if indicated based on assessment)					
1. Remove speculum after taking samples of vaginal and cervical discharge.					
2. Immerse both gloved hands in 0.5% solution. Remove gloves by turning inside out. <ul style="list-style-type: none"> ● If disposing of gloves, place in leakproof container or plastic bag. ● If reusing surgical gloves (not recommended), submerge in 0.5% chlorine solution for 10 minutes for decontamination. 					
3. Prepare for saline and KOH wet mounts and Gram staining.					
4. Identify on the wet mounts: <ul style="list-style-type: none"> ● Vaginal epithelial cells ● Trichomoniasis (if present) ● Monilia (if present) ● Clue cells (if present) 					
5. Identify on the Gram stain: <ul style="list-style-type: none"> ● WBC (polymorphonuclear white cells) (if present) ● Gram-negative intracellular diplococci (GNID) (if present) ● Clue cells (if present) 					
6. When testing is done, wash hands thoroughly with soap and water; and dry them with clean, dry cloth or air-dry.					
7. Treat any conditions identified according to national guidelines/local protocols (refer, if needed).					

LEARNING GUIDE FOR IUD CLINICAL SKILLS

(ADAPTED FOR THE TCU 380A WITH SAFE LOAD)

(To be used by **Participants**)

Rate the performance of each step or task observing the following rating scale:

- 1 Needs Improvement:** Step or task not performed correctly or out of sequence (if necessary) or is omitted
- 2 Competently Performed:** Step or task performed correctly in proper sequence (if necessary) but participant does not progress from step to step efficiently
- 3 Proficiently Performed:** Step or task efficiently and precisely performed in the proper sequence (if necessary)

LEARNING GUIDE FOR IUD <i>CLINICAL SKILLS</i> (TCU 380A WITH SAFE LOAD)					
STEP/TASK	CASES				
IUD INSERTION					
Client Assessment					
1. Greet the client with kindness and respect.					
2. Determine that the client has been counseled about the IUD in general, as well about the insertion procedure.					
History					
3. Review the client's contraceptive, menstrual, and obstetric history to confirm that the IUD is an appropriate choice for the client, focusing especially on ensuring that the client is not pregnant . Ask about: <ul style="list-style-type: none"> ● Heavy, prolonged, or menstrual painful periods ● Parity/gravida ● Childbirth or abortion within the last 4 weeks; signs/symptoms of infection with either ● Possibility of pregnancy (delayed or missing period, unprotected sex since last menstrual period [LMP]) (Note: If needed, use checklist provided in Appendix B to be reasonably sure the client is not pregnant.)					
4. Review the client's pertinent (general and reproductive) medical history to confirm that the IUD is an appropriate choice for the client, focusing especially on ensuring that the client is not at high individual risk of sexually transmitted infections (STIs) . Ask about: <ul style="list-style-type: none"> ● Severe anemia ● HIV/AIDS ● Complicated valvular heart disease ● Cancer of the reproductive organs ● Trophoblastic disease ● Pelvic tuberculosis ● Unexplained vaginal bleeding ● High individual risk of STIs <ul style="list-style-type: none"> – STI within last 3 months (self or partner) – Multiple partners (self or partner) – Partner with symptoms of STI (e.g., penile discharge) ● Diagnosis of pelvic inflammatory disease (PID), gonorrhea, chlamydia, or other STIs (within last 3 months) ● Symptoms of PID, gonorrhea, chlamydia, or other STIs <ul style="list-style-type: none"> – Lower abdominal pain – Current unusual or purulent vaginal discharge 					
Physical Examination					
5. Ensure that a high-level disinfected (HLD) instrument pan (or sterile pack), supplies, and light source are available.					

LEARNING GUIDE FOR IUD <i>CLINICAL SKILLS</i> (TCU 380A WITH SAFE LOAD)					
STEP/TASK	CASES				
6. Have the client empty her bladder and wash and rinse her perineal area if possible.					
7. Help the client onto the examination table.					
8. Tell the client what is going to be done, and ask her if she has any questions.					
9. Wash your hands thoroughly with soap and water; and dry them with clean, dry cloth or allow them to air dry.					
10. Check for signs of anemia/severe anemia .					
11. Palpate the abdomen : <ul style="list-style-type: none"> • Check for suprapubic tenderness. • Check for swellings, bulges, masses, or other gross-abnormalities. 					
12. Drape the client appropriately for pelvic exam.					
13. Wash your hands <u>again</u> thoroughly with soap and water; and dry them with clean, dry cloth or allow them to air dry.					
14. Open the HLD instrument pan (or sterile pack) without touching instruments.					
15. Using an HLD (or sterile) pick-up forcep, arrange the instruments and supplies on an HLD pan (or sterile tray), being very careful not to touch parts of the instruments that will go into the vagina or uterus.					
16. Put new/clean examination or HLD (or sterile) surgical gloves on both hands.					
17. Inspect the external genitalia and urethral opening: <ul style="list-style-type: none"> • Check for ulcers, lesions, and sores. • Check for buboes (enlarged groin nodes). • Palpate Skene's and Bartholin's glands, checking for tenderness or discharge. 					
Note: <ul style="list-style-type: none"> • If findings are normal (findings that do not suggest possible infection or other pelvic problems), perform the bimanual exam first and the speculum exam second. This allows you to sound the uterus and insert the IUD without having to insert the speculum twice. • If there are potential problems (findings that suggest possible infection or other pelvic problems), perform the speculum exam first and a bimanual exam second. 					
18a. Perform a bimanual exam (see Note above): <ul style="list-style-type: none"> • Determine the size, shape, and position of uterus. • Check for enlargement or tenderness of the adnexa and for cervical motion tenderness. • Check for uterine abnormalities that may interfere with proper placement of the IUD. 					
18b. Perform rectovaginal exam only if: <ul style="list-style-type: none"> • Position or size of uterus is unclear. • There is a possible mass behind the uterus. 					
18c. If rectovaginal exam is performed, do the following before continuing: <ul style="list-style-type: none"> • Immerse both gloved hands in 0.5% solution. • Remove gloves by turning inside out and dispose of them • Put on new/clean examination or HLD (or sterile) gloves. 					
19. Perform a speculum exam (see Note above) of the vagina and cervix (by gently spreading the labia with two fingers and then inserting the HLD [or sterile] speculum, starting obliquely and then rotating it to the horizontal position): <ul style="list-style-type: none"> • Check for purulent vaginal discharge. • Check for ulcers, lesions, and sores. • Check cervix for purulent cervicitis, bleeding, erosions, or narrowing of the cervical canal (stenosis). (Note: If laboratory testing is indicated and available, refer to steps at the end of learning guide.)					

LEARNING GUIDE FOR IUD <i>CLINICAL SKILLS</i> (TCU 380A WITH SAFE LOAD)					
STEP/TASK	CASES				
Preinsertion and Insertion Steps					
1. If both bimanual and speculum exams are normal, give the client a brief overview of the insertion procedure, encourage her to ask questions, and provide reassurance if needed. Remind her to let you know if she feels any pain.					
Sounding the Uterus					
2. Gently insert the HLD (or sterile) speculum (if not already done; visualize cervix), and cleanse the cervical os and vaginal wall with an appropriate antiseptic two or more times.					
3. Gently grasp the cervix with an HLD (or sterile) tenaculum and apply gentle traction. Do not lock the tenaculum beyond the first notch, unless necessary.					
4. While gently pulling on the tenaculum, and without allowing the tip of the sound to touch the vaginal walls or the speculum blades, carefully insert the sound into the cervical os.					
5a. Gently advance the sound at the appropriate angle (based on bimanual exam).					
5b. STOP advancing the sound when a slight resistance is felt, and confirm the position of the uterus (anterior or posterior) for the IUD insertion. Do not use force at any stage of this procedure.					
6. Remove the sound. (Do not pass the sound into the uterus more than once.)					
7. Determine the depth of the uterus by noting the level of mucus or wetness on the sound.					
8. Place the sound in 0.5% chlorine solution for 10 minutes for decontamination.					
Loading the IUD in Its Sterile Package (Important: Do not load the IUD until the final decision to insert the IUD has been made.)					
9. Adjust the contents of the package (through the package) so that the “T” is fully inside insertion tube.					
10. Peel the clear plastic cover half-way to blue depth-gauge.					
11. Place the white plunger rod in the clear insertion tube.					
12. Push the insertion tube into the Safe Load device: <ul style="list-style-type: none"> Place the package back on the clean, hard, flat surface. Stabilize the Safe Load device with one hand. Slide measurement insert toward sealed end of the package. Still holding the Safe Load device, push the insertion tube toward the Safe Load device. Continue pushing until the arms of the T are inside the “profile” of the Safe Load device. (Important: Do not fold the arms of the T into the Safe Load device or insertion tube more than 5 minutes before the IUD is to be inserted into the uterus.)					
13. When the arms of the T are touching the sides of the insertion tube, slowly pull the insertion tube away from the folded arms of the IUD until it comes out of the Safe Load device.					
14. While keeping the Safe Load device flat on the table, gently push and rotate the insertion tube back over the tips of the folded arms of the T, so that both tips are caught inside the insertion tube. Push the folded arms of the IUD into the insertion tube only as far as necessary to keep them fixed in the tube.					
15. Turn the insertion tube by 90 degrees (in either direction), and gently withdraw the insertion tube along with the loaded IUD from the device, but do not remove the loaded IUD from the package.					

LEARNING GUIDE FOR IUD <i>CLINICAL SKILLS</i> (TCU 380A WITH SAFE LOAD)				
STEP/TASK	CASES			
16. With the loaded IUD still in the package, set the blue depth-gauge to the corresponding measurement obtained from sounding the uterus. <ul style="list-style-type: none"> Press down on the gauge with one hand to keep it stable. At the same time, slide the insertion tube with your other hand until the tip of the IUD aligns with the tip in the diagram on the measurement insert. 				
17. Align the blue depth-gauge and the folded arms of the T so that they are both in horizontal position (flat against the package on the table).				
18. Finish peeling back the cover in one brisk, continuous movement with one hand, while holding the loaded IUD through the open end of the package against the white backing (on the table) with the other hand.				
19. Lift the loaded IUD from the package, without allowing it to touch anything that is not sterile. Keep it level so that the IUD does not fall out, and be careful not to push the white rod toward the IUD.				
<i>Inserting the IUD</i>				
20. Put new/clean examination or HLD (or sterile) surgical gloves on both hands (if taken off to load the IUD).				
21. Give the client a brief overview of the procedure, encourage her to ask questions, and provide reassurance if needed. Remind her to let you know if she feels any pain.				
22. Hold the IUD so that blue depth-gauge is in horizontal position. Gently grasp the tenaculum with the other hand and gently pull outward and downward.				
23a. Carefully insert the loaded IUD into the vaginal canal and gently push it through the cervical os and into uterine cavity at the appropriate angle (based on sounding).				
23b. Gently advance the loaded IUD into the uterine cavity until the blue depth-gauge comes into contact with the cervix or slight resistance is felt. (Important: Be careful not to touch the wall of vagina or the speculum blades with the tip of the loaded IUD. Do not use force at any stage of this procedure.)				
24. Hold the tenaculum and white rod stationary with one hand, and release the arms of the T from the insertion tube using the withdrawal technique: <ul style="list-style-type: none"> Gently pull the insertion tube away from the IUD (while holding the white rod stable) until it touches the circular thumb grip of the white plunger rod. Remove the white plunger rod, while holding the insertion tube stationary. 				
25. Gently push insertion tube upward again, toward the fundus of the uterus, until you feel a slight resistance.				
26. Partially withdraw the insertion tube from the cervical canal until the string can be seen extending from the cervical os.				
27. Use HLD (or sterile) sharp Mayo scissors to cut the IUD strings to 3–4 cm length.				
28. Gently remove the tenaculum and place in 0.5% chlorine solution for 10 minutes for decontamination.				
29. Examine the cervix. If there is bleeding where the tenaculum was attached to the cervix, use HLD (or sterile) forceps to place cotton (or gauze) swab on the affected tissue, and apply gentle pressure for 30–60 seconds.				
30. Gently remove speculum and place in 0.5% chlorine solution for 10 minutes for decontamination.				
31. Ask the client if she is experiencing nausea, mild to moderate lower abdominal pain/cramping, and dizziness or fainting. If she is experiencing any of these symptoms, provide reassurance and allow her remain on the examination table until she feels better (she should stay in clinic for at least 15 to 30 minutes). Begin performing the postinsertion steps.				

LEARNING GUIDE FOR IUD <i>CLINICAL SKILLS</i> (TCU 380A WITH SAFE LOAD)					
STEP/TASK	CASES				
Postinsertion Steps					
1. Before removing the gloves, place all used instruments in 0.5% chlorine solution for 10 minutes for decontamination. (After the client has left, wipe the examination table with 0.5% chlorine solution.)					
2. Dispose of waste materials (e.g., cotton balls) by placing in a leak-proof container (with a tight-fitting lid) or plastic bag.					
3. Immerse both gloved hands in 0.5% chlorine solution. Remove gloves by turning inside out: <ul style="list-style-type: none"> • If disposing of gloves, place in the leak-proof container or plastic bag. • If reusing surgical gloves (not recommended), submerge them in 0.5% chlorine solution for 10 minutes for decontamination. 					
4. Wash hands thoroughly with soap and water; and dry them with a clean, dry cloth or air dry.					
5. Provide postinsertion instructions (key messages for IUD users): <ul style="list-style-type: none"> • Basic facts about her IUD (e.g., type, how long effective, when to replace/remove) • No protection against STIs; need for condoms if at risk • Possible side effects • Warning signs (PAINS) • Checking for possible IUD expulsion • When to return to clinic 					
IUD REMOVAL					
Preremoval Steps					
1. Greet the woman with kindness and respect, and establish purpose of visit.					
2. Ask the woman her reason for having the IUD removed.					
3. Determine whether she will have another IUD inserted immediately, start a different method, or neither.					
4. Counsel as appropriate: <ul style="list-style-type: none"> • Ensure that she understands that there is immediate return to fertility after IUD removal. • Review the client's reproductive goals and need for STI protection • Discuss other contraceptive methods if desired. 					
5. Ensure that a high-level disinfected (HLD) instrument pan (or sterile pack), supplies, and light source are available.					
6. Open the HLD instrument pan (or sterile pack) without touching instruments. Using an HLD (or sterile) pick-up forcep, arrange the instruments and supplies on an HLD pan (or sterile tray), being very careful not to touch parts of the instruments that will go into the vagina or uterus.					
7. Have the client empty her bladder and wash and rinse her perineal area if possible.					
8. Help the client onto the examination table.					
9. Wash your hands thoroughly with soap and water; and dry them with clean, dry cloth or allow them to air dry.					
10. Put new/clean examination or HLD (or sterile) surgical gloves on both hands.					
11. Give the client a brief overview of the procedure, encourage her to ask questions, and provide reassurance as needed. Remind her to let you know if she feels any pain.					

LEARNING GUIDE FOR IUD <i>CLINICAL SKILLS</i> (TCU 380A WITH SAFE LOAD)					
STEP/TASK	CASES				
Removing the IUD					
1. Insert an HLD (or sterile) speculum to visualize the IUD strings.					
2. Cleanse the cervix (especially the os) and vagina with an appropriate antiseptic two or more times.					
3. Alert the client immediately before you remove the IUD. Ask her to take slow, deep breaths and inform her that she may feel some discomfort and cramping, which is normal.					
4. Grasp the IUD strings close to the cervix with an HLD (or sterile) hemostat or other narrow forceps.					
5. Apply steady but gentle traction, pulling the strings toward you, to remove the IUD. Do not use excessive force.					
6. Show the IUD to client.					
7. Place the IUD in 0.5% chlorine solution for 10 minutes for decontamination.					
8. If the woman is having a new IUD inserted, insert it now if appropriate. If she is not having a new IUD inserted, gently remove the speculum and place it in 0.5% chlorine solution for 10 minutes for decontamination.					
9. Ask the client if she is experiencing nausea, mild to moderate lower abdominal pain/cramping, and dizziness or fainting. If she is experiencing any of these symptoms, provide reassurance and allow her remain on the examination table until she feels better (she should stay in clinic for at least 15 to 30 minutes).					
Postremoval Steps					
1. Before removing the gloves, place all used instruments in 0.5% chlorine solution for 10 minutes for decontamination. (After the client has left, wipe the examination table with 0.5% chlorine solution.)					
2. Dispose of waste materials (e.g., cotton balls) by placing in a leak-proof container (with a tight-fitting lid) or plastic bag.					
3. Immerse both gloved hands in 0.5% chlorine solution. Remove gloves by turning inside out: <ul style="list-style-type: none"> ● If disposing of gloves, place in the leak-proof container or plastic bag. ● If reusing surgical gloves (not recommended), submerge them in 0.5% chlorine solution for 10 minutes for decontamination. 					
4. Wash hands thoroughly with soap and water; and dry them with a clean, dry cloth or air dry.					
5. If the woman has had a new IUD inserted, review key messages for IUD users. [If the woman is starting a different method, provide the information she needs to use it safely and effectively (and a back-up method, if needed).]					
*Laboratory Testing (if available and if indicated based on assessment)					
1. Remove speculum after taking samples of vaginal and cervical discharge.					
2. Immerse both gloved hands in 0.5% solution. Remove gloves by turning inside out. <ul style="list-style-type: none"> ● If disposing of gloves, place in leakproof container or plastic bag. ● If reusing surgical gloves (not recommended), submerge in 0.5% chlorine solution for 10 minutes for decontamination. 					
3. Prepare for saline and KOH wet mounts and Gram staining.					
4. Identify on the wet mounts: <ul style="list-style-type: none"> ● Vaginal epithelial cells ● Trichomoniasis (if present) ● Monilia (if present) ● Clue cells (if present) 					

LEARNING GUIDE FOR IUD <i>CLINICAL SKILLS</i> (TCU 380A WITH SAFE LOAD)					
STEP/TASK	CASES				
5. Identify on the Gram stain: <ul style="list-style-type: none"> • WBC (polymorphonuclear white cells) (if present) • Gram-negative intracellular diplococci (GNID) (if present) • Clue cells (if present) 					
6. When testing is done, wash hands thoroughly with soap and water; and dry them with clean, dry cloth or air-dry.					
7. Treat any conditions identified according to national guidelines/local protocols (refer, if needed).					

LEARNING GUIDE FOR IUD CLINICAL SKILLS

(ADAPTED FOR THE MULTILOAD CU375)

(To be used by **Participants**)

Rate the performance of each step or task observing the following rating scale:

- 1 Needs Improvement:** Step or task not performed correctly or out of sequence (if necessary) or is omitted
- 2 Competently Performed:** Step or task performed correctly in proper sequence (if necessary) but participant does not progress from step to step efficiently
- 3 Proficiently Performed:** Step or task efficiently and precisely performed in the proper sequence (if necessary)

LEARNING GUIDE FOR IUD <i>CLINICAL SKILLS</i> (MULTILOAD CU375)					
STEP/TASK	CASES	1	2	3	4
IUD INSERTION					
Client Assessment					
1. Greet the client with kindness and respect.					
2. Determine that the client has been counseled about the IUD in general, as well about the insertion procedure.					
History					
3. Review the client's contraceptive, menstrual, and obstetric history to confirm that the IUD is an appropriate choice for the client, focusing especially on ensuring that the client is not pregnant . Ask about: <ul style="list-style-type: none"> ● Heavy, prolonged, or menstrual painful periods ● Parity/gravida ● Childbirth or abortion within the last 4 weeks; signs/symptoms of infection with either ● Possibility of pregnancy (delayed or missing period, unprotected sex since last menstrual period [LMP]) (Note: If needed, use checklist provided in Appendix B to be reasonably sure the client is not pregnant.)					
4. Review the client's pertinent (general and reproductive) medical history to confirm that the IUD is an appropriate choice for the client, focusing especially on ensuring that the client is not at high individual risk of sexually transmitted infections (STIs) . Ask about: <ul style="list-style-type: none"> ● Severe anemia ● HIV/AIDS ● Complicated valvular heart disease ● Cancer of the reproductive organs ● Trophoblastic disease ● Pelvic tuberculosis ● Unexplained vaginal bleeding ● High individual risk of STIs <ul style="list-style-type: none"> - STI within last 3 months (self or partner) - Multiple partners (self or partner) - Partner with symptoms of STI (e.g., penile discharge) ● Diagnosis of pelvic inflammatory disease (PID), gonorrhea, chlamydia, or other STIs (within last 3 months) ● Symptoms of PID, gonorrhea, chlamydia, or other STIs <ul style="list-style-type: none"> - Lower abdominal pain - Current unusual or purulent vaginal discharge 					
Physical Examination					
5. Ensure that a high-level disinfected (HLD) instrument pan (or sterile pack), supplies, and light source are available.					

LEARNING GUIDE FOR IUD <i>CLINICAL SKILLS</i> (MULTILOAD CU375)					
STEP/TASK	CASES				
6. Have the client empty her bladder and wash and rinse her perineal area if possible.					
7. Help the client onto the examination table.					
8. Tell the client what is going to be done, and ask her if she has any questions.					
9. Wash your hands thoroughly with soap and water; and dry them with clean, dry cloth or allow them to air dry.					
10. Check for signs of anemia/severe anemia .					
11. Palpate the abdomen : <ul style="list-style-type: none"> • Check for suprapubic tenderness. • Check for swellings, bulges, masses, or other gross-abnormalities. 					
12. Drape the client appropriately for pelvic exam.					
13. Wash your hands <u>again</u> thoroughly with soap and water; and dry them with clean, dry cloth or allow them to air dry.					
14. Open the HLD instrument pan (or sterile pack) without touching instruments.					
15. Using an HLD (or sterile) pick-up forcep, arrange the instruments and supplies on an HLD pan (or sterile tray), being very careful not to touch parts of the instruments that will go into the vagina or uterus.					
16. Put new/clean examination or HLD (or sterile) surgical gloves on both hands.					
17. Inspect the external genitalia and urethral opening: <ul style="list-style-type: none"> • Check for ulcers, lesions, and sores. • Check for buboes (enlarged groin nodes). • Palpate Skene's and Bartholin's glands, checking for tenderness or discharge. 					
Note: <ul style="list-style-type: none"> • If findings are normal (findings that do not suggest possible infection or other pelvic problems), perform the bimanual exam first and the speculum exam second. This allows you to sound the uterus and insert the IUD without having to insert the speculum twice. • If there are potential problems (findings that suggest possible infection or other pelvic problems), perform the speculum exam first and a bimanual exam second. 					
18a. Perform a bimanual exam (see Note above): <ul style="list-style-type: none"> • Determine the size, shape, and position of uterus. • Check for enlargement or tenderness of the adnexa and for cervical motion tenderness. • Check for uterine abnormalities that may interfere with proper placement of the IUD. 					
18b. Perform rectovaginal exam only if: <ul style="list-style-type: none"> • Position or size of uterus is unclear. • There is a possible mass behind the uterus. 					
18c. If rectovaginal exam is performed, do the following before continuing: <ul style="list-style-type: none"> • Immerse both gloved hands in 0.5% solution. • Remove gloves by turning inside out and dispose of them • Put on new/clean examination or HLD (or sterile) gloves. 					
19. Perform a speculum exam (see Note above) of the vagina and cervix (by gently spreading the labia with two fingers and then inserting the HLD [or sterile] speculum, starting obliquely and then rotating it to the horizontal position): <ul style="list-style-type: none"> • Check for purulent vaginal discharge. • Check for ulcers, lesions, and sores. • Check cervix for purulent cervicitis, bleeding, erosions, or narrowing of the cervical canal (stenosis). (Note: If laboratory testing is indicated and available, refer to steps at the end of learning guide.)					

LEARNING GUIDE FOR IUD <i>CLINICAL SKILLS</i> (MULTILOAD CU375)					
STEP/TASK	CASES				
Preinsertion and Insertion Steps					
1. If both bimanual and speculum exams are normal, give the client a brief overview of the insertion procedure, encourage her to ask questions, and provide reassurance if needed. Remind her to let you know if she feels any pain.					
Sounding the Uterus					
2. Gently insert the HLD (or sterile) speculum (if not already done; visualize cervix), and cleanse the cervical os and vaginal wall with an appropriate antiseptic two or more times.					
3. Gently grasp the cervix with an HLD (or sterile) tenaculum and apply gentle traction. Do not lock the tenaculum beyond the first notch, unless necessary.					
4. While gently pulling on the tenaculum, and without allowing the tip of the sound to touch the vaginal walls or the speculum blades, carefully insert the sound into the cervical os.					
5a. Gently advance the sound at the appropriate angle (based on bimanual exam).					
5b. STOP advancing the sound when a slight resistance is felt, and confirm the position of the uterus (anterior or posterior) for the IUD insertion. Do not use force at any stage of this procedure.					
6. Remove the sound. (Do not pass the sound into the uterus more than once.)					
7. Determine the depth of the uterus by noting the level of mucus or wetness on the sound.					
8. Place the sound in 0.5% chlorine solution for 10 minutes for decontamination.					
Removing Multiload from its Sterile Package (Note: The Multiload does not require loading because its vertical stem is “preloaded” in the inserter tube, and its arms are flexible enough to adapt to the shape of the cervical canal.)					
9. Prepare to remove Multiload from its sterile package: <ul style="list-style-type: none"> Place package on flat surface. Remove wrapping 1/3 of the way by lifting the transparent front sheet from the bottom end of the package 					
10. Grasp the insertion tube and the IUD string together at the lower end of the tube.					
11. Move the cervical guard to the number corresponding to the measurement obtained from sounding the uterus, using the no-touch technique.					
12. Remove loaded insertion tube from the package without touching anything that is not sterile. Make sure to hold the tube level so that the IUD does not fall out.					
Inserting Multiload					
13. Put new/clean examination or HLD (or sterile) surgical gloves on both hands (if not already done).					
14. Give the client a brief overview of the procedure, encourage her to ask questions, and provide reassurance if needed. Remind her to let you know if she feels any pain. (Note: Women who are having the Multiload Cu375 inserted may feel more discomfort [than those having a Copper T inserted] as the arms of the IUD pass through the cervical os, especially if they are nulliparous.)					
15. Hold the IUD so that cervical guard is in horizontal position. Gently grasp the tenaculum with the other hand and gently pull outward and downward.					
16a. Carefully insert the loaded IUD into the vaginal canal and gently push it through the cervical os and into uterine cavity at the appropriate angle (based on sounding).					

LEARNING GUIDE FOR IUD <i>CLINICAL SKILLS</i> (MULTILOAD CU375)					
STEP/TASK	CASES				
16b. Gently advance the loaded IUD into the uterine cavity until the cervical guard comes into contact with the cervix or slight resistance is felt. (Important: Be careful not to touch the wall of vagina or the speculum blades with the tip of the loaded IUD. Do not use force at any stage of this procedure.)					
17. Continuing to apply gentle downward traction to the tenaculum, remove the inserter tube from the cervical canal.					
18. Partially withdraw the insertion tube from the cervical canal until the string can be seen extending from the cervical os.					
19. Use HLD (or sterile) sharp Mayo scissors to cut the IUD strings to 3–4 cm length.					
20. Gently remove the tenaculum and place in 0.5% chlorine solution for 10 minutes for decontamination.					
21. Examine the cervix. If there is bleeding where the tenaculum was attached to the cervix, use HLD (or sterile) forceps to place cotton (or gauze) swab on the affected tissue, and apply gentle pressure for 30–60 seconds.					
22. Gently remove speculum and place in 0.5% chlorine solution for 10 minutes for decontamination.					
23. Ask the client if she is experiencing nausea, mild to moderate lower abdominal pain/cramping, and dizziness or fainting. If she is experiencing any of these symptoms, provide reassurance and allow her remain on the examination table until she feels better (she should stay in clinic for at least 15 to 30 minutes). Begin performing the postinsertion steps.					
Postinsertion Steps					
1. Before removing the gloves, place all used instruments in 0.5% chlorine solution for 10 minutes for decontamination. (After the client has left, wipe the examination table with 0.5% chlorine solution.)					
2. Dispose of waste materials (e.g., cotton balls) by placing in a leak-proof container (with a tight-fitting lid) or plastic bag.					
3. Immerse both gloved hands in 0.5% chlorine solution. Remove gloves by turning inside out: <ul style="list-style-type: none"> ● If disposing of gloves, place in the leak-proof container or plastic bag. ● If reusing surgical gloves (not recommended), submerge them in 0.5% chlorine solution for 10 minutes for decontamination. 					
4. Wash hands thoroughly with soap and water; and dry them with a clean, dry cloth or air dry.					
5. Provide postinsertion instructions (key messages for IUD users): <ul style="list-style-type: none"> ● Basic facts about her IUD (e.g., type, how long effective, when to replace/remove) ● No protection against STIs; need for condoms if at risk ● Possible side effects ● Warning signs (PAINS) ● Checking for possible IUD expulsion ● When to return to clinic 					
IUD REMOVAL					
Preremoval Steps					
1. Greet the woman with kindness and respect, and establish purpose of visit.					
2. Ask the woman her reason for having the IUD removed.					
3. Determine whether she will have another IUD inserted immediately, start a different method, or neither.					

LEARNING GUIDE FOR IUD <i>CLINICAL SKILLS</i> (MULTILOAD CU375)					
STEP/TASK	CASES				
4. Counsel as appropriate: <ul style="list-style-type: none"> • Ensure that she understands that there is immediate return to fertility after IUD removal. • Review the client's reproductive goals and need for STI protection • Discuss other contraceptive methods if desired. 					
5. Ensure that a high-level disinfected (HLD) instrument pan (or sterile pack), supplies, and light source are available.					
6. Open the HLD instrument pan (or sterile pack) without touching instruments. Using an HLD (or sterile) pick-up forcep, arrange the instruments and supplies on an HLD pan (or sterile tray), being very careful not to touch parts of the instruments that will go into the vagina or uterus.					
7. Have the client empty her bladder and wash and rinse her perineal area if possible.					
8. Help the client onto the examination table.					
9. Wash your hands thoroughly with soap and water; and dry them with clean, dry cloth or allow them to air dry.					
10. Put new/clean examination or HLD (or sterile) surgical gloves on both hands.					
11. Give the client a brief overview of the procedure, encourage her to ask questions, and provide reassurance as needed. Remind her to let you know if she feels any pain. (Note: Women who are having the Multiload Cu375 removed may feel more discomfort [than those having a Copper T removed] as the arms of the IUD pass through the cervical os, especially if they are nulliparous.)					
Removing Multiload					
1. Insert an HLD (or sterile) speculum to visualize the IUD strings.					
2. Cleanse the cervix (especially the os) and vagina with an appropriate antiseptic two or more times.					
3. Apply a HLD (or sterile) tenaculum to the cervix to straighten out the uterine axis. This will help prevent the IUD arms from breaking as they pass through the os.					
4. Alert the client immediately before you remove the IUD. Ask her to take slow, deep breaths and inform her that she may feel some discomfort and cramping, which is normal.					
5. Grasp the IUD strings close to the cervix with an HLD (or sterile) hemostat or other narrow forceps. With the Multiload, it is important to grasp the strings as close to the cervical os as possible.					
6. Apply steady but gentle traction, pulling the strings toward you, to remove the IUD. Do not use excessive force.					
7. Show the IUD to client.					
8. Place the IUD in 0.5% chlorine solution for 10 minutes for decontamination.					
9. If the woman is having a new IUD inserted, insert it now if appropriate. If she is not having a new IUD inserted, gently remove the speculum and place it in 0.5% chlorine solution for 10 minutes for decontamination.					
10. Ask the client if she is experiencing nausea, mild to moderate lower abdominal pain/cramping, and dizziness or fainting. If she is experiencing any of these symptoms, provide reassurance and allow her remain on the examination table until she feels better (she should stay in clinic for at least 15 to 30 minutes).					

LEARNING GUIDE FOR IUD <i>CLINICAL SKILLS</i> (MULTILOAD CU375)					
STEP/TASK	CASES				
Postremoval Steps					
1. Before removing the gloves, place all used instruments in 0.5% chlorine solution for 10 minutes for decontamination. (After the client has left, wipe the examination table with 0.5% chlorine solution.)					
2. Dispose of waste materials (e.g., cotton balls) by placing in a leak-proof container (with a tight-fitting lid) or plastic bag.					
3. Immerse both gloved hands in 0.5% chlorine solution. Remove gloves by turning inside out: <ul style="list-style-type: none"> • If disposing of gloves, place in the leak-proof container or plastic bag. • If reusing surgical gloves (not recommended), submerge them in 0.5% chlorine solution for 10 minutes for decontamination. 					
4. Wash hands thoroughly with soap and water; and dry them with a clean, dry cloth or air dry.					
5. If the woman has had a new IUD inserted, review key messages for IUD users. [If the woman is starting a different method, provide the information she needs to use it safely and effectively (and a back-up method, if needed).]					
*Laboratory Testing (if available and if indicated based on assessment)					
1. Remove speculum after taking samples of vaginal and cervical discharge.					
2. Immerse both gloved hands in 0.5% solution. Remove gloves by turning inside out. <ul style="list-style-type: none"> • If disposing of gloves, place in leakproof container or plastic bag. • If reusing surgical gloves (not recommended), submerge in 0.5% chlorine solution for 10 minutes for decontamination. 					
3. Prepare for saline and KOH wet mounts and Gram staining.					
4. Identify on the wet mounts: <ul style="list-style-type: none"> • Vaginal epithelial cells • Trichomoniasis (if present) • Monilia (if present) • Clue cells (if present) 					
5. Identify on the Gram stain: <ul style="list-style-type: none"> • WBC (polymorphonuclear white cells) (if present) • Gram-negative intracellular diplococci (GNID) (if present) • Clue cells (if present) 					
6. When testing is done, wash hands thoroughly with soap and water; and dry them with clean, dry cloth or air-dry.					
7. Treat any conditions identified according to national guidelines/local protocols (refer, if needed).					

PRACTICE CHECKLIST FOR IUD COUNSELING AND CLINICAL SKILLS

(ADAPTED FOR THE REGULAR COPPER T 380A)

(To be used by **Participants** for practice)

Place a “✓” in case box of step/task is performed satisfactorily, an “X” if it is not performed satisfactorily, or **N/O** if not observed.

Satisfactory: Performs the step or task according to the standard procedure or guidelines

Unsatisfactory: Unable to perform the step or task according to the standard procedure or guidelines

Not Observed: Step, task or skill not performed by participant during evaluation by trainer

Participant _____ Course Dates _____

CHECKLIST FOR IUD COUNSELING AND CLINICAL SKILLS (REGULAR COPPER T 380A)					
STEP/TASK	CASES				
METHOD-SPECIFIC COUNSELING					
1. Once the woman has chosen to use the IUD, assess her knowledge of the method.					
2. Ensure that she knows that menstrual changes are a common side effect among IUD users, and that the IUD does not protect against STIs.					
3. Describe the medical assessment required before IUD insertion, as well as the procedures for IUD insertion and removal.					
4. Encourage her to ask questions. Provide additional information and reassurance as needed.					
IUD INSERTION					
Client Assessment (Use Appendix B to confirm that the woman is eligible for IUD use.)					
1. Review the client’s medical and reproductive history.					
2. Ensure that equipment and supplies are available and ready to use.					
3. Have the client empty her bladder and wash her perineal area.					
4. Help the client onto the examination table.					
5. Tell the client what is going to be done, and ask her if she has any questions.					
6. Wash hands thoroughly and dry them.					
7. Palpate the abdomen .					
8. Wash hands thoroughly and dry them <u>again</u> .					
9. Put clean or HLD gloves on both hands.					
10. Inspect the external genitalia.					
Note:					
<ul style="list-style-type: none"> ● If findings are normal, perform the bimanual exam first and the speculum exam second. ● If there are potential problems, perform the speculum exam first and a bimanual exam second. 					
11a. Perform a bimanual exam (see Note above)					
11b. Perform rectovaginal exam only if indicated.					
11c. If rectovaginal exam is performed, change gloves before continuing.					
12. Perform a speculum exam (see Note above). (Note: If laboratory testing is indicated and available, take samples now.)					

CHECKLIST FOR IUD COUNSELING AND CLINICAL SKILLS (REGULAR COPPER T 380A)					
STEP/TASK	CASES				
Preinsertion and Insertion Steps (Using aseptic, “no touch” technique throughout)					
1. Provide an overview of the insertion procedure. Remind her to let you know if she feels any pain.					
2. Gently insert the HLD (or sterile) speculum to visualize the cervix (if not already done), and cleanse the cervical os and vaginal wall with antiseptic.					
3. Gently grasp the cervix with an HLD (or sterile) tenaculum and apply gentle traction.					
4. Insert the HLD (or sterile) sound using the “no touch” technique.					
5. Load the IUD in its sterile package.					
6. Set the blue depth-gauge to the measurement of the uterus.					
7. Carefully insert the loaded IUD, and release it into the uterus using the “withdrawal” technique.					
8. Gently push the insertion tube upward again until you feel a slight resistance.					
9. Withdraw the rod, and partially withdraw the insertion tube until the IUD strings can be seen.					
10. Use HLD (or sterile) sharp Mayo scissors to cut the IUD strings to 3–4 cm length.					
11. Gently remove the tenaculum and speculum and place in 0.5% chlorine solution for 10 minutes for decontamination..					
12. Examine the cervix for bleeding.					
13. Ask how the client is feeling and begin performing the postinsertion steps.					
Postinsertion Steps					
1. Before removing the gloves, place all used instruments in 0.5% chlorine solution for 10 minutes for decontamination.					
2. Properly dispose of waste materials.					
3. Process gloves according to recommended IP practices.					
4. Wash hands thoroughly and dry them.					
5. Provide postinsertion instructions (key messages for IUD users): <ul style="list-style-type: none"> ● Basic facts about her IUD (e.g., type, how long effective, when to replace/remove) ● No protection against STIs; need for condoms if at risk ● Possible side effects ● Warning signs (PAINS) ● Checking for possible IUD expulsion ● When to return to clinic 					
IUD REMOVAL					
Preremoval Steps					
1. Ask the woman her reason for having the IUD removed.					
2. Determine whether she will have another IUD inserted immediately, start a different method, or neither.					
3. Review the client’s reproductive goals and need for STI protection, and counsel as appropriate.					
4. Ensure that equipment and supplies are available and ready to use.					
5. Have the client empty her bladder and wash her perineal area.					
6. Help the client onto the examination table.					
7. Wash hands thoroughly and dry them.					
8. Put new or HLD gloves on both hands.					

CHECKLIST FOR IUD COUNSELING AND CLINICAL SKILLS (REGULAR COPPER T 380A)					
STEP/TASK	CASES				
Removing the IUD					
1. Provide an overview of the insertion procedure. Remind her to let you know if she feels any pain.					
2. Gently insert the HLD (or sterile) speculum to visualize the strings, and cleanse the cervical os and vaginal wall with antiseptic.					
3. Alert the client immediately before you remove the IUD.					
4. Grasp the IUD strings close to the cervix with an HLD (or sterile) hemostat or other narrow forceps.					
5. Apply steady but gentle traction, pulling the strings toward you, to remove the IUD. Do not use excessive force.					
6. Show the IUD to client.					
7. Place the IUD in 0.5% chlorine solution for 10 minutes for decontamination.					
8. If the woman is having a new IUD inserted, insert it now if appropriate. [If she is not having a new IUD inserted, gently remove the speculum and place it in 0.5% chlorine solution for 10 minutes for decontamination.]					
9. Ask how the client is feeling and begin performing the postremoval steps.					
Postremoval Steps					
1. Before removing the gloves, place all used instruments and the IUD in 0.5% chlorine solution for 10 minutes for decontamination.					
2. Properly dispose of waste materials.					
3. Process gloves according to recommended IP practices.					
4. Wash hands thoroughly and dry them.					
5. If the woman has had a new IUD inserted, review key messages for IUD users. [If the woman is starting a different method, provide the information she needs to use it safely and effectively (and a back-up method, if needed).]					

PRACTICE CHECKLIST FOR IUD COUNSELING AND CLINICAL SKILLS

(ADAPTED FOR THE TCU 380A WITH SAFE LOAD)

(To be used by **Participants** for practice)

Place a "✓" in case box of step/task is performed satisfactorily, an "X" if it is not performed satisfactorily, or **N/O** if not observed.

Satisfactory: Performs the step or task according to the standard procedure or guidelines

Unsatisfactory: Unable to perform the step or task according to the standard procedure or guidelines

Not Observed: Step, task or skill not performed by participant during evaluation by trainer

Participant _____ Course Dates _____

CHECKLIST FOR IUD COUNSELING AND CLINICAL SKILLS (TCU 380A WITH SAFE LOAD)					
STEP/TASK	CASES				
METHOD-SPECIFIC COUNSELING					
1. Once the woman has chosen to use the IUD, assess her knowledge of the method.					
2. Ensure that she knows that menstrual changes are a common side effect among IUD users, and that the IUD does not protect against STIs.					
3. Describe the medical assessment required before IUD insertion, as well as the procedures for IUD insertion and removal.					
4. Encourage her to ask questions. Provide additional information and reassurance as needed.					
IUD INSERTION					
Client Assessment (Use Appendix B to confirm that the woman is eligible for IUD use.)					
1. Review the client's medical and reproductive history.					
2. Ensure that equipment and supplies are available and ready to use.					
3. Have the client empty her bladder and wash her perineal area.					
4. Help the client onto the examination table.					
5. Tell the client what is going to be done, and ask her if she has any questions.					
6. Wash hands thoroughly and dry them.					
7. Palpate the abdomen .					
8. Wash hands thoroughly and dry them <u>again</u> .					
9. Put clean or HLD gloves on both hands.					
10. Inspect the external genitalia.					
Note:					
<ul style="list-style-type: none"> ● If findings are normal, perform the bimanual exam first and the speculum exam second. ● If there are potential problems, perform the speculum exam first and a bimanual exam second. 					
11a. Perform a bimanual exam (see Note above)					
11b. Perform rectovaginal exam only if indicated.					
11c. If rectovaginal exam is performed, change gloves before continuing.					
12. Perform a speculum exam (see Note above). (Note: If laboratory testing is indicated and available, take samples now.)					

CHECKLIST FOR IUD COUNSELING AND CLINICAL SKILLS (TCU 380A WITH SAFE LOAD)					
STEP/TASK	CASES				
Preinsertion and Insertion Steps (Using aseptic, “no touch” technique throughout)					
1. Provide an overview of the insertion procedure. Remind her to let you know if she feels any pain.					
2. Gently insert the HLD (or sterile) speculum to visualize the cervix (if not already done), and cleanse the cervical os and vaginal wall with antiseptic.					
3. Gently grasp the cervix with an HLD (or sterile) tenaculum and apply gentle traction.					
4. Insert the HLD (or sterile) sound using the “no touch” technique.					
5. Load the IUD in its sterile package.					
6. Set the blue depth-gauge to the measurement of the uterus.					
7. Carefully insert the loaded IUD, and release it into the uterus using the “withdrawal” technique.					
8. Gently push the insertion tube upward again until you feel a slight resistance.					
9. Withdraw the rod, and partially withdraw the insertion tube until the IUD strings can be seen.					
10. Use HLD (or sterile) sharp Mayo scissors to cut the IUD strings to 3–4 cm length.					
11. Gently remove the tenaculum and speculum and place in 0.5% chlorine solution for 10 minutes for decontamination..					
12. Examine the cervix for bleeding.					
13. Ask how the client is feeling and begin performing the postinsertion steps.					
Postinsertion Steps					
1. Before removing the gloves, place all used instruments in 0.5% chlorine solution for 10 minutes for decontamination.					
2. Properly dispose of waste materials.					
3. Process gloves according to recommended IP practices.					
4. Wash hands thoroughly and dry them.					
5. Provide postinsertion instructions (key messages for IUD users): <ul style="list-style-type: none"> ● Basic facts about her IUD (e.g., type, how long effective, when to replace/remove) ● No protection against STIs; need for condoms if at risk ● Possible side effects ● Warning signs (PAINS) ● Checking for possible IUD expulsion ● When to return to clinic 					
IUD REMOVAL					
Preremoval Steps					
1. Ask the woman her reason for having the IUD removed.					
2. Determine whether she will have another IUD inserted immediately, start a different method, or neither.					
3. Review the client’s reproductive goals and need for STI protection, and counsel as appropriate.					
4. Ensure that equipment and supplies are available and ready to use.					
5. Have the client empty her bladder and wash her perineal area.					
6. Help the client onto the examination table.					
7. Wash hands thoroughly and dry them.					
8. Put new or HLD gloves on both hands.					

CHECKLIST FOR IUD COUNSELING AND CLINICAL SKILLS (TCU 380A WITH SAFE LOAD)					
STEP/TASK	CASES				
Removing the IUD					
1. Provide an overview of the insertion procedure. Remind her to let you know if she feels any pain.					
2. Gently insert the HLD (or sterile) speculum to visualize the strings, and cleanse the cervical os and vaginal wall with antiseptic.					
3. Alert the client immediately before you remove the IUD.					
4. Grasp the IUD strings close to the cervix with an HLD (or sterile) hemostat or other narrow forceps.					
5. Apply steady but gentle traction, pulling the strings toward you, to remove the IUD. Do not use excessive force.					
6. Show the IUD to client.					
7. Place the IUD in 0.5% chlorine solution for 10 minutes for decontamination.					
8. If the woman is having a new IUD inserted, insert it now if appropriate. [If she is not having a new IUD inserted, gently remove the speculum and place it in 0.5% chlorine solution for 10 minutes for decontamination.]					
9. Ask how the client is feeling and begin performing the postremoval steps.					
Postremoval Steps					
1. Before removing the gloves, place all used instruments and the IUD in 0.5% chlorine solution for 10 minutes for decontamination.					
2. Properly dispose of waste materials.					
3. Process gloves according to recommended IP practices.					
4. Wash hands thoroughly and dry them.					
5. If the woman has had a new IUD inserted, review key messages for IUD users. [If the woman is starting a different method, provide the information she needs to use it safely and effectively (and a back-up method, if needed).]					

PRACTICE CHECKLIST FOR IUD COUNSELING AND CLINICAL SKILLS

(ADAPTED FOR THE MULTILOAD CU375)

(To be used by **Participants** for practice)

Place a “✓” in case box of step/task is performed satisfactorily, an “X” if it is not performed satisfactorily, or **N/O** if not observed.

Satisfactory: Performs the step or task according to the standard procedure or guidelines

Unsatisfactory: Unable to perform the step or task according to the standard procedure or guidelines

Not Observed: Step, task or skill not performed by participant during evaluation by trainer

Participant _____ Course Dates _____

CHECKLIST FOR IUD COUNSELING AND CLINICAL SKILLS (MULTILOAD CU375)					
STEP/TASK	CASES				
METHOD-SPECIFIC COUNSELING					
1. Once the woman has chosen to use the IUD, assess her knowledge of the method.					
2. Ensure that she knows that menstrual changes are a common side effect among IUD users, and that the IUD does not protect against STIs.					
3. Describe the medical assessment required before IUD insertion, as well as the procedures for IUD insertion and removal.					
4. Encourage her to ask questions. Provide additional information and reassurance as needed.					
IUD INSERTION					
Client Assessment (Use Appendix B to confirm that the woman is eligible for IUD use.)					
1. Review the client’s medical and reproductive history.					
2. Ensure that equipment and supplies are available and ready to use.					
3. Have the client empty her bladder and wash her perineal area.					
4. Help the client onto the examination table.					
5. Tell the client what is going to be done, and ask her if she has any questions.					
6. Wash hands thoroughly and dry them.					
7. Palpate the abdomen .					
8. Wash hands thoroughly and dry them <u>again</u> .					
9. Put clean or HLD gloves on both hands.					
10. Inspect the external genitalia.					
Note:					
<ul style="list-style-type: none"> ● If findings are normal, perform the bimanual exam first and the speculum exam second. ● If there are potential problems, perform the speculum exam first and a bimanual exam second. 					
11a. Perform a bimanual exam (see Note above)					
11b. Perform rectovaginal exam only if indicated.					
11c. If rectovaginal exam is performed, change gloves before continuing.					
12. Perform a speculum exam (see Note above). (Note: If laboratory testing is indicated and available, take samples now.)					

CHECKLIST FOR IUD COUNSELING AND CLINICAL SKILLS (MULTILOAD CU375)					
STEP/TASK	CASES				
Preinsertion and Insertion Steps (Using aseptic, “no touch” technique throughout)					
1. Provide an overview of the insertion procedure. Remind her to let you know if she feels any pain.					
2. Gently insert the HLD (or sterile) speculum to visualize the cervix (if not already done), and cleanse the cervical os and vaginal wall with antiseptic.					
3. Gently grasp the cervix with an HLD (or sterile) tenaculum and apply gentle traction.					
4. Insert the HLD (or sterile) sound using the “no touch” technique.					
5. Grasp the insertion tube and the IUD string together at the lower end of the tube.					
6. Move the cervical guard to the measurement of the uterus.					
7. Gently advance the loaded IUD into the uterine cavity until the cervical guard touches cervix or a slight resistance is felt					
8. Continuing to apply gentle downward traction to the tenaculum, remove the inserter tube from the cervical canal.					
9. Partially withdraw the insertion tube from the cervical canal until the string can be seen extending from the cervical os.					
10. Use HLD (or sterile) sharp Mayo scissors to cut the IUD strings to 3–4 cm length.					
11. Gently remove the tenaculum and speculum and place in 0.5% chlorine solution for 10 minutes for decontamination..					
12. Examine the cervix for bleeding.					
13. Ask how the client is feeling and begin performing the postinsertion steps.					
Postinsertion Steps					
1. Before removing the gloves, place all used instruments in 0.5% chlorine solution for 10 minutes for decontamination.					
2. Properly dispose of waste materials.					
3. Process gloves according to recommended IP practices.					
4. Wash hands thoroughly and dry them.					
5. Provide postinsertion instructions (key messages for IUD users): <ul style="list-style-type: none"> ● Basic facts about her IUD (e.g., type, how long effective, when to replace/remove) ● No protection against STIs; need for condoms if at risk ● Possible side effects ● Warning signs (PAINS) ● Checking for possible IUD expulsion ● When to return to clinic 					
IUD REMOVAL					
Preremoval Steps					
1. Ask the woman her reason for having the IUD removed.					
2. Determine whether she will have another IUD inserted immediately, start a different method, or neither.					
3. Review the client’s reproductive goals and need for STI protection, and counsel as appropriate.					
4. Ensure that equipment and supplies are available and ready to use.					
5. Have the client empty her bladder and wash her perineal area.					
6. Help the client onto the examination table.					

CHECKLIST FOR IUD COUNSELING AND CLINICAL SKILLS (MULTILOAD CU375)					
STEP/TASK	CASES				
7. Wash hands thoroughly and dry them.					
8. Put new or HLD gloves on both hands.					
Removing the IUD					
1. Provide an overview of the insertion procedure. Remind her to let you know if she feels any pain.					
2. Gently insert the HLD (or sterile) speculum to visualize the strings, and cleanse the cervical os and vaginal wall with antiseptic.					
3. Apply an HLD (or sterile) tenaculum to the cervix to straighten out the uterine axis.					
4. Alert the client immediately before you remove the IUD.					
5. Grasp the IUD strings close to the cervix with an HLD (or sterile) hemostat or other narrow forceps. With the Multiload, it is important to grasp the strings as close to the cervical os as possible.					
6. Show the IUD to client.					
7. Place the IUD in 0.5% chlorine solution for 10 minutes for decontamination.					
8. If the woman is having a new IUD inserted, insert it now if appropriate. [If she is not having a new IUD inserted, gently remove the speculum and place it in 0.5% chlorine solution for 10 minutes for decontamination.]					
9. Ask how the client is feeling and begin performing the postremoval steps.					
Postremoval Steps					
1. Before removing the gloves, place all used instruments and the IUD in 0.5% chlorine solution for 10 minutes for decontamination.					
2. Properly dispose of waste materials.					
3. Process gloves according to recommended IP practices.					
4. Wash hands thoroughly and dry them.					
5. If the woman has had a new IUD inserted, review key messages for IUD users. [If the woman is starting a different method, provide the information she needs to use it safely and effectively (and a back-up method, if needed).]					

IUD COURSE EVALUATION

(To be completed by **Participants**)

Please indicate your opinion of the course components using the following rate scale:

5-Strongly Agree 4-Agree 3-No Opinion 2-Disagree 1-Strongly Disagree

COURSE COMPONENT	RATING
1. The Precourse Questionnaire helped me to study more effectively.	
2. The role play sessions on counseling skills were helpful.	
3. There was sufficient time scheduled for practicing counseling through role play and with clients and volunteers.	
4. The demonstration helped me get a better understanding of how to insert and remove IUDs prior to practicing with the pelvic model.	
5. The practice sessions with the pelvic model made it easier for me to perform IUD insertion and removal when working with actual clients.	
6. There was sufficient time scheduled for practicing IUD insertion and removal with clients.	
7. The interactive training approach used in this course made it easier for me to learn how to provide IUD services.	
8. The time allotted for this course was sufficient for learning how to provide IUD services.	
9. I feel confident in IUD insertion and removal.	
10. I feel confident in using the infection prevention practices recommended for IUD services.	

ADDITIONAL COMMENTS (use reverse side if needed)

1. What topics (if any) should be **added** (and why) to improve the course?

2. What topics (if any) should be **deleted** (and why) to improve the course?

INTRAUTERINE CONTRACEPTIVE DEVICES (IUDs): INTRODUCTION

Slide 1



Slide 2

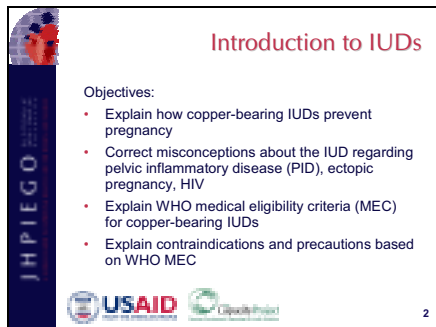

Slide 3

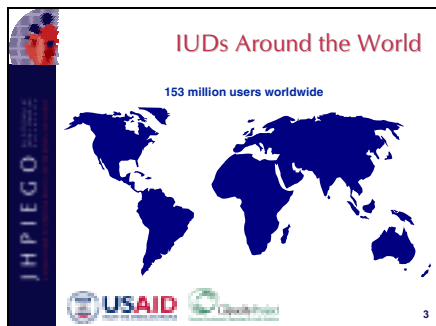

Slide 4

IUD Use in Different Parts of the World

- 60% (92 million) of world's married IUD users live in China
- 12% in other Asian countries
- 11% in Eastern Europe and Central Asia
- 7% in Near East and North Africa
- 5% in Latin America and the Caribbean
- 5% in developed countries
- <1% in Sub-Saharan Africa

USAID Contraceptive Project

4

Slide 5

Resurgence of Interest in the IUD

- Despite persistent misconceptions, IUD users have higher **satisfaction rates** (99% versus 91% for pill users) and **continuation rates** than users of many other methods
- Recent research has led to important changes in WHO MEC
- Risk of PID in IUD users is negligible
- The IUD is appropriate for most women, including...

USAID Contraceptive Project

5

Slide 6

Resurgence of Interest in the IUD (cont.)

- Women with the following characteristics/conditions:
 - Under 20 years of age and/or nulliparous
 - HIV-infected and clinically well
 - AIDS and on antiretroviral therapy (ARV) therapy and clinically well
 - History of ectopic pregnancy
 - History of PID (assuming no known risk factors for sexually transmitted infections [STIs])
 - Living in area with high STI prevalence (assuming no known risk factors for STIs)

USAID Contraceptive Project

6

Slide 7

Types of Medicated IUDs

Copper-bearing:

- Copper T 380A*
- TCu 200C
- Multiload Cu250 and Cu375
- Nova-T

Levonorgestrel-releasing:

- Mirena®

* This learning package focuses on the Copper T 380A



7

Slide 8

Copper T 380A

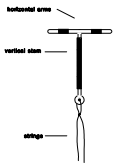

- Comes in regular and Safe Load varieties
- Effective for at least 12 years



8

Slide 9

Copper-Bearing IUDs: Mechanisms of Action

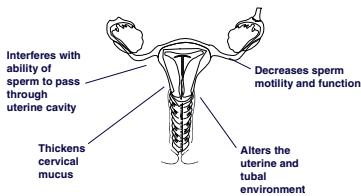

- Interferes with ability of sperm to pass through uterine cavity
- Thickens cervical mucus
- Decreases sperm motility and function
- Alters the uterine and tubal environment



9

Slide 10

IUDs: Basic Attributes

- Highly effective (failure rate less than 1% in first year of use)
- Long-term protection (at least 12 years)
- Effective immediately
- Immediate return to fertility upon removal

USAID Contraceptive Project 10

Slide 11

IUDs: Other Reasons Women Like Them

In addition to reasons listed on previous slide:

- No hormonal side effects
- Inexpensive over time
- Convenient:
 - No day-to-day action needed
 - After first routine check-up, no need to return to clinic unless experiencing problems
 - No additional supplies needed

USAID Contraceptive Project 11

Slide 12

IUDs: Considerations

- Pelvic examination required before IUD insertion
- IUD insertion and removal require provider trained in these procedures
- Client can not stop use whenever she wants (provider-dependent)

USAID Contraceptive Project 12

Slide 13

IUDs: Side Effects

Menstrual problems:

- Increase in menstrual bleeding (up to 50%) and associated cramping/pain
 - Worse during first few months
 - Most common reason for removal
- Cramping may occur during insertion and for several days afterward
- Spotting/light bleeding may occur for first few days or months after insertion

JHPIEGO
USAID
Quality Project

13

Slide 14

IUDs: Health Benefits

- May help protect against endometrial and cervical cancers

JHPIEGO
USAID
Quality Project

14

Slide 15

IUDs: Health Risks

Expulsion (uncommon):

- May be spontaneously expelled (2–8%)
- More common in first 3 months and during menstrual period
- Factors that increase risk:
 - Nulliparity
 - Heavy menstrual flow
 - Insertion immediately postpartum or after second-trimester abortion

JHPIEGO
USAID
Quality Project

15

Slide 16

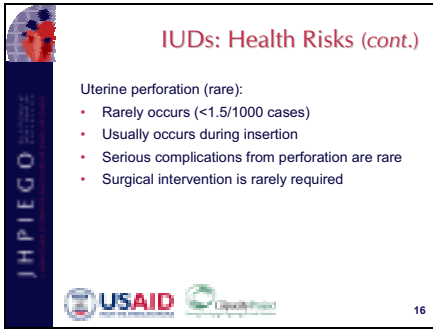

IUDs: Health Risks (cont.)

Uterine perforation (rare):

- Rarely occurs (<1.5/1000 cases)
- Usually occurs during insertion
- Serious complications from perforation are rare
- Surgical intervention is rarely required

JHPIEGO
USAID
Dignity Project

16

Slide 17

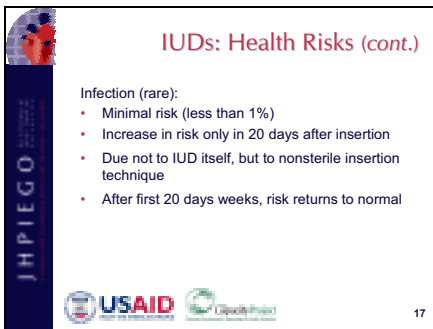

IUDs: Health Risks (cont.)

Infection (rare):

- Minimal risk (less than 1%)
- Increase in risk only in 20 days after insertion
- Due not to IUD itself, but to nonsterile insertion technique
- After first 20 days weeks, risk returns to normal

JHPIEGO
USAID
Dignity Project

17

Slide 18

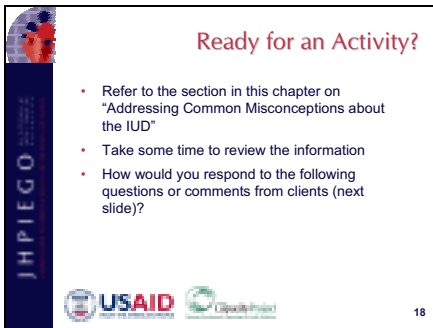

Ready for an Activity?

- Refer to the section in this chapter on "Addressing Common Misconceptions about the IUD"
- Take some time to review the information
- How would you respond to the following questions or comments from clients (next slide)?

JHPIEGO
USAID
Dignity Project

18

Slide 19

Ready for an Activity?

- "I heard the IUD can cause an ectopic pregnancy. Is this true?"
- "Doesn't the IUD cause PID?"
- "Can't the IUD make you sterile?"
- "I thought women who are HIV-infected couldn't use the IUD."
- "I've never been pregnant before. Shouldn't I use another method?"

JHPIEGO
USAID
Dignity Project

19

Slide 20

WHO Medical Eligibility Criteria

- **Category 1:** Use the method in any circumstances (no restrictions)
- **Category 2:** Generally use the method (advantages generally outweigh risks)
- **Category 3:** Use of the method not usually recommended (risks generally outweigh advantages)
- **Category 4:** Method not to be used (too risky)

JHPIEGO
USAID
Dignity Project

20

Slide 21

IUDs: Who Should Not Use (WHO Category 4)

IUD should not be inserted if a woman:

- Is pregnant
- Has puerperal sepsis or post-septic abortion
- Has a distorted uterine cavity
- Has current PID, gonorrhea, or chlamydia*
- Has current purulent cervical discharge*

* Category 2 for continuation while undergoing evaluation and treatment

JHPIEGO
USAID
Dignity Project

21

Slide 22

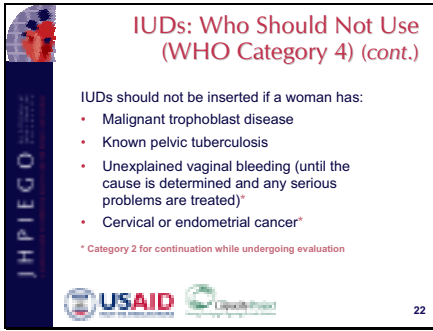

IUDs: Who Should Not Use (WHO Category 4) (cont.)

IUDs should not be inserted if a woman has:

- Malignant trophoblast disease
- Known pelvic tuberculosis
- Unexplained vaginal bleeding (until the cause is determined and any serious problems are treated)*
- Cervical or endometrial cancer*

* Category 2 for continuation while undergoing evaluation

JHPIEGO
USAID
Dignity Project

22

Slide 23

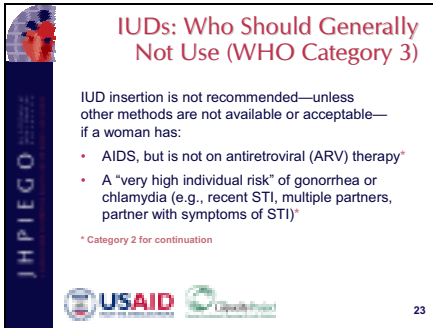

IUDs: Who Should Generally Not Use (WHO Category 3)

IUD insertion is not recommended—unless other methods are not available or acceptable—if a woman has:

- AIDS, but is not on antiretroviral (ARV) therapy*
- A "very high individual risk" of gonorrhea or chlamydia (e.g., recent STI, multiple partners, partner with symptoms of STI)*

* Category 2 for continuation

JHPIEGO
USAID
Dignity Project

23

Slide 24

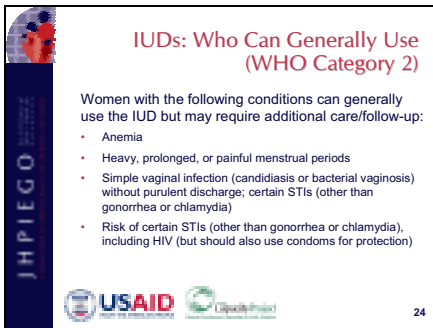

IUDs: Who Can Generally Use (WHO Category 2)

Women with the following conditions can generally use the IUD but may require additional care/follow-up:

- Anemia
- Heavy, prolonged, or painful menstrual periods
- Simple vaginal infection (candidiasis or bacterial vaginosis) without purulent discharge; certain STIs (other than gonorrhea or chlamydia)
- Risk of certain STIs (other than gonorrhea or chlamydia), including HIV (but should also use condoms for protection)

JHPIEGO
USAID
Dignity Project

24

Slide 25

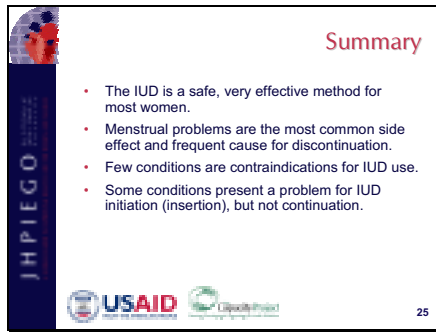

Summary

- The IUD is a safe, very effective method for most women.
- Menstrual problems are the most common side effect and frequent cause for discontinuation.
- Few conditions are contraindications for IUD use.
- Some conditions present a problem for IUD initiation (insertion), but not continuation.

JHPIEGO
USAID
Quality Project
25

INTRAUTERINE CONTRACEPTIVE DEVICES (IUDs): EDUCATION AND COUNSELING

Slide 1

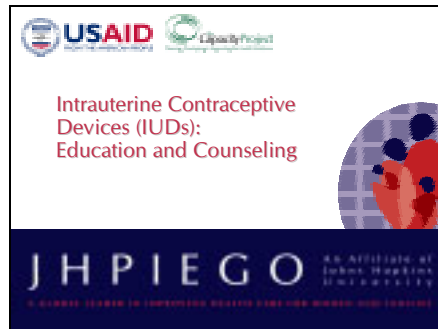

Slide 2



Slide 3

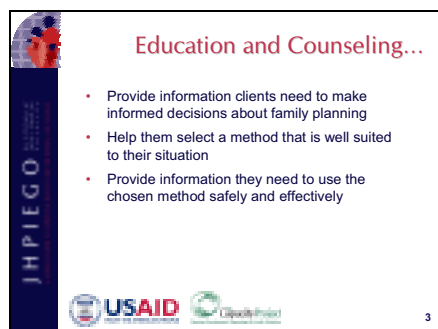

Slide 4



Client Rights

- Right to **unbiased** information about family planning, and to a wide range of contraceptive options
- Right to use method selected if available and medically eligible
- Right to switch/start/stop method as desired
- Right to kindness and respect, and to discuss concerns openly

JHPIEGO
USAID
Contraceptive Project
4

Slide 5



Client Rights (cont.)

- Right to confidentiality and privacy (bodily)
- Right to safe and comfortable environment
- Right to refuse examination, procedure, or treatment
- Right to appropriate referral and follow-up
- Right to continuity of services
- Right to express views about services provided

JHPIEGO
USAID
Contraceptive Project
5

Slide 6

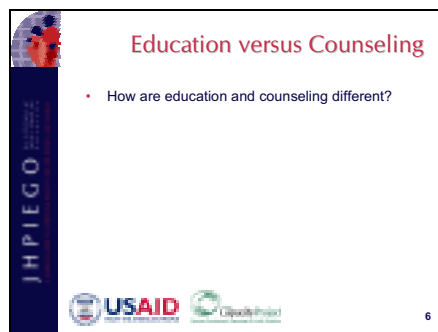

Education versus Counseling

- How are education and counseling different?

JHPIEGO
USAID
Contraceptive Project
6

Slide 7

Tips for Client Education

- Engage learners in an activity
- Focus/limit key messages
- Ensure appropriate timing
- Assess client understanding and retention
- Provide printed materials

- What might be some strategies for helping clients understand and retain information?
- What might be some ways to conduct a "group education" session?

USAID
Contraceptive Project

7

Slide 8

Effective Counseling

- What might be some characteristics of an effective counselor?

USAID
Contraceptive Project

8

Slide 9

Some Key Factors in Family Planning Decisions

- Reproductive goals
- Effectiveness
- Reversibility of method
- Side effects
- Health benefits/risks
- Need for protection against STIs
- Cost
- Availability
- Convenience

USAID
Contraceptive Project

9

Slide 10

The Counseling Process

- **General family planning counseling:** focus on assisting client in choosing a method
- **Method-specific counseling:** focus on ensuring client's safe and effective use of method chosen
- **Follow-up counseling:** focus on assessing client's satisfaction or problems with method chosen

10

Slide 11

Important Points for Potential IUD Users

- **Providing correct information:**
 - Long-term, highly effective, reversible contraceptive protection
 - Safe and appropriate for use by most women
- **Addressing rumors and myths:**
 - What have you heard about the IUD?

11

Slide 12

Important Points for Potential IUD Users (cont.)

Informing of important considerations:

- No protection against STIs; women at risk should use condoms (in addition to IUD)
- Menstrual changes are a common side effect
- A complete medical assessment (including a pelvic examination) is needed to confirm that a woman can use the IUD
- Starting and stopping the IUD requires a procedure performed by a skilled provider

12

Slide 13



GATHER Technique in Counseling

- Greet
- Ask
- Tell
- Help
- Explain
- Return/Refer

Ready for a demonstration?

USAID Quality Project

13

Slide 14



Summary

- It is important to aid, not persuade, the client in choosing a contraceptive.
- A client needs both education and counseling to select an appropriate method; and to help ensure safe, effective, continued use of the method chosen.
- Education and counseling should be integrated throughout the visit.

USAID Quality Project

14

INTRAUTERINE CONTRACEPTIVE DEVICES (IUDs): INFECTION PREVENTION

Slide 1

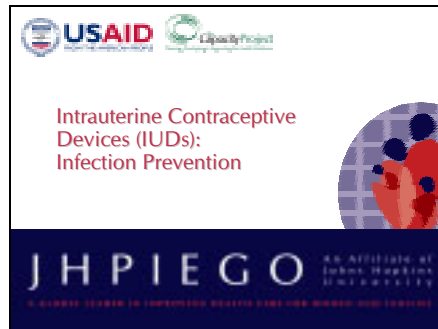

Slide 2

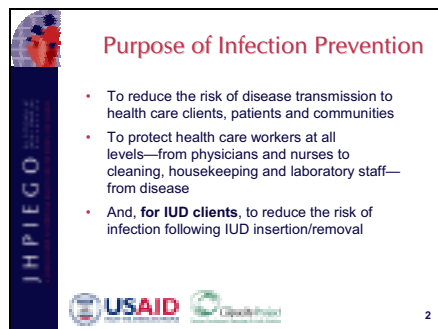

Slide 3

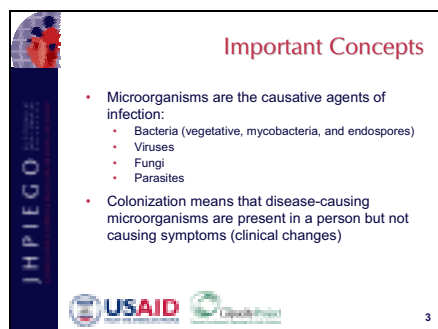

Slide 4

Important Concepts (cont.)

- Infection means that the colonizing microorganisms are now causing symptoms (clinical changes) or disease
- Infection prevention involves placing protective barriers (physical, chemical or mechanical) between an individual and microorganisms



4

Slide 5

Understanding the Disease Transmission Cycle

- All microorganisms can cause infection
- All humans are susceptible to most infectious agents unless immune (naturally or by vaccination)
- Risk of infection is related to the number and virulence of organisms
- Number of organisms needed to cause infection varies with location (blood stream—least; intact skin—greatest)



5

Slide 6

Standard Precautions

- Are guidelines designed to create barriers between microorganisms and an individual to prevent the spread of infection (i.e., the barrier serves to break the disease transmission cycle)



6

Slide 7

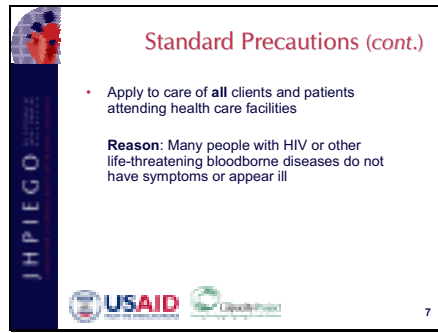

Standard Precautions (cont.)

- Apply to care of **all** clients and patients attending health care facilities

Reason: Many people with HIV or other life-threatening bloodborne diseases do not have symptoms or appear ill

JHPIEGO
USAID
Dignity Project

7

Slide 8

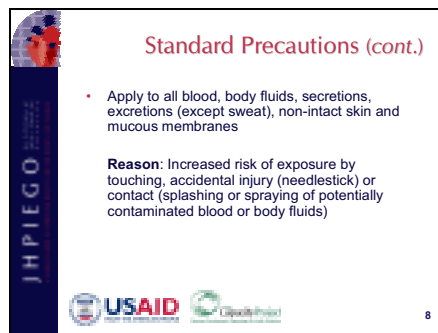

Standard Precautions (cont.)

- Apply to all blood, body fluids, secretions, excretions (except sweat), non-intact skin and mucous membranes

Reason: Increased risk of exposure by touching, accidental injury (needlestick) or contact (splashing or spraying of potentially contaminated blood or body fluids)

JHPIEGO
USAID
Dignity Project

8

Slide 9

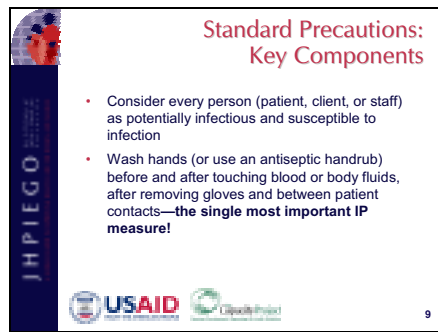

**Standard Precautions:
Key Components**

- Consider every person (patient, client, or staff) as potentially infectious and susceptible to infection
- Wash hands (or use an antiseptic handrub) before and after touching blood or body fluids, after removing gloves and between patient contacts—**the single most important IP measure!**

JHPIEGO
USAID
Dignity Project

9

Slide 10



**Standard Precautions:
Key Components (cont.)**

- Wear gloves (both hands) before touching anything wet—broken skin, mucous membranes, blood or body fluids, soiled instruments or contaminated waste materials—and before performing invasive procedures
- Use physical barriers (protective goggles, face masks and aprons) if splashes and spills of blood or body fluids (secretions and excretions) are likely

JHPIEGO
USAID
Quality Project
10

Slide 11



**Standard Precautions:
Key Components (cont.)**

- Use antiseptic agents for cleansing the skin or mucous membrane prior to surgery, cleaning wounds or doing handrubs or surgical handscrubs with an alcohol-based antiseptic product
- Use safe work practices such as not recapping or bending needles, safely passing sharp instruments and suturing, when appropriate, with blunt needles

JHPIEGO
USAID
Quality Project
11

Slide 12



**Standard Precautions:
Key Components (cont.)**

- Safely dispose of infectious waste materials to protect those who handle them and prevent injury or spread of infection to the community
- Process instruments, gloves, and other items after use by first decontaminating them, then thoroughly cleaning them, and then either high-level disinfecting or sterilizing them using recommended procedures

JHPIEGO
USAID
Quality Project
12

Slide 13

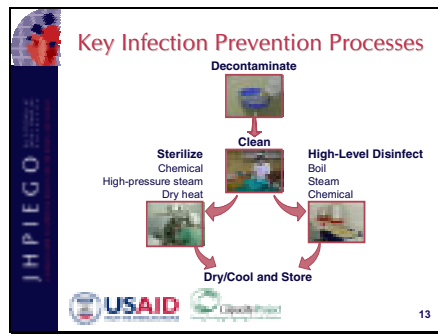

Slide 14



Slide 15

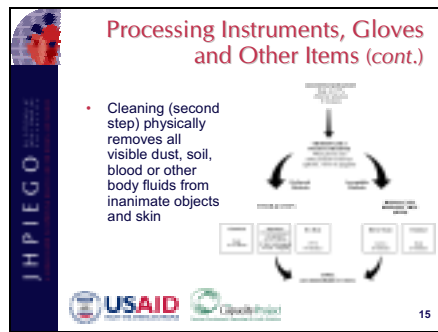

Slide 16



Processing Instruments, Gloves and Other Items (cont.)

- Final-processing by high-level disinfection (HLD) or sterilization is the third step
 - HLD eliminates all organisms (bacteria, viruses, fungi, and parasites) except some endospores
- Sterilization eliminates all organisms including all endospores

Note: HLD is the recommended method of final-processing for IUD services. (It is sufficient because mucus membranes are left intact during IUD insertion.)

JHPIEGO
USAID
Dignity Project

16

Slide 17

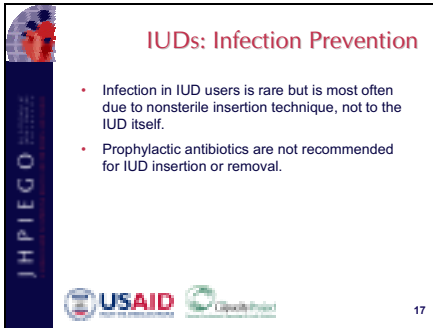

IUDs: Infection Prevention

- Infection in IUD users is rare but is most often due to nonsterile insertion technique, not to the IUD itself.
- Prophylactic antibiotics are not recommended for IUD insertion or removal.

JHPIEGO
USAID
Dignity Project

17

Slide 18

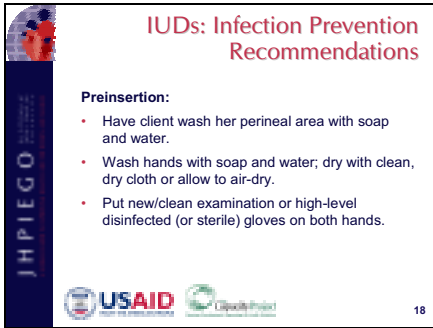

IUDs: Infection Prevention Recommendations

Preinsertion:

- Have client wash her perineal area with soap and water.
- Wash hands with soap and water; dry with clean, dry cloth or allow to air-dry.
- Put new/clean examination or high-level disinfected (or sterile) gloves on both hands.

JHPIEGO
USAID
Dignity Project

18

Slide 19

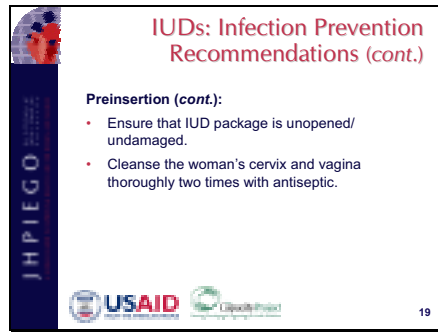

IUDs: Infection Prevention Recommendations (cont.)

Preinsertion (cont.):

- Ensure that IUD package is unopened/undamaged.
- Cleanse the woman's cervix and vagina thoroughly two times with antiseptic.

USAID
Global Project

19

Slide 20

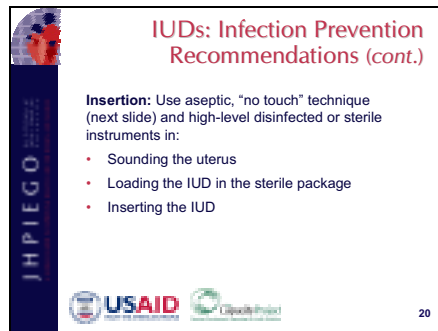

IUDs: Infection Prevention Recommendations (cont.)

Insertion: Use aseptic, "no touch" technique (next slide) and high-level disinfected or sterile instruments in:

- Sounding the uterus
- Loading the IUD in the sterile package
- Inserting the IUD

USAID
Global Project

20

Slide 21

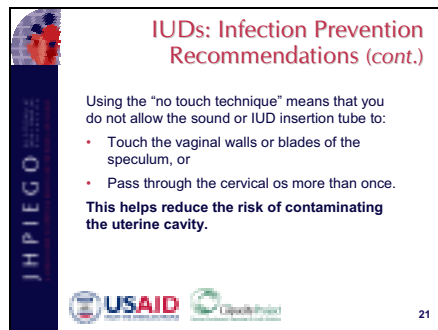

IUDs: Infection Prevention Recommendations (cont.)

Using the "no touch technique" means that you do not allow the sound or IUD insertion tube to:

- Touch the vaginal walls or blades of the speculum, or
- Pass through the cervical os more than once.

This helps reduce the risk of contaminating the uterine cavity.

USAID
Global Project

21

Slide 22

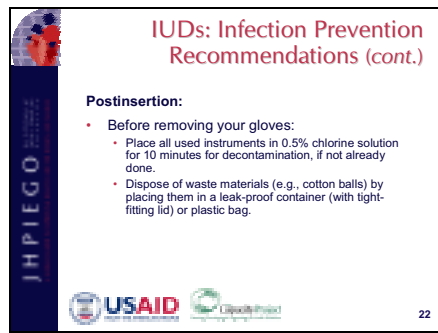

IUDs: Infection Prevention Recommendations (cont.)

Postinsertion:

- **Before removing your gloves:**
 - Place all used instruments in 0.5% chlorine solution for 10 minutes for decontamination, if not already done.
 - Dispose of waste materials (e.g., cotton balls) by placing them in a leak-proof container (with tight-fitting lid) or plastic bag.

JHPIEGO
USAID
Dignity Project

22

Slide 23

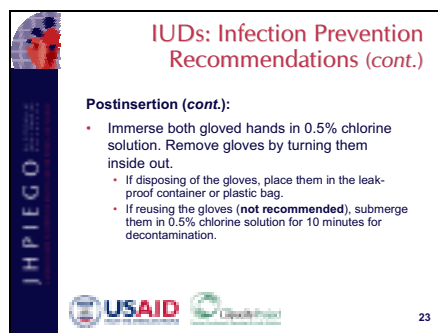

IUDs: Infection Prevention Recommendations (cont.)

Postinsertion (cont.):

- Immerse both gloved hands in 0.5% chlorine solution. Remove gloves by turning them inside out.
 - If disposing of the gloves, place them in the leak-proof container or plastic bag.
 - If reusing the gloves (**not recommended**), submerge them in 0.5% chlorine solution for 10 minutes for decontamination.

JHPIEGO
USAID
Dignity Project

23

Slide 24

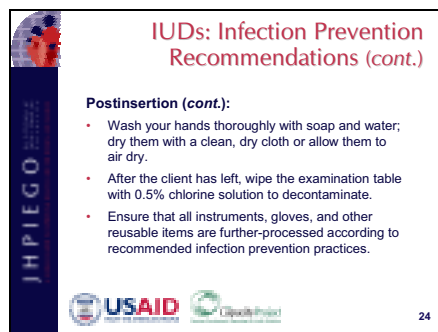

IUDs: Infection Prevention Recommendations (cont.)

Postinsertion (cont.):

- Wash your hands thoroughly with soap and water; dry them with a clean, dry cloth or allow them to air dry.
- After the client has left, wipe the examination table with 0.5% chlorine solution to decontaminate.
- Ensure that all instruments, gloves, and other reusable items are further-processed according to recommended infection prevention practices.

JHPIEGO
USAID
Dignity Project

24

Slide 25

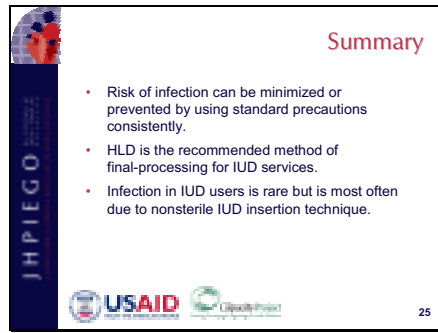

Summary

- Risk of infection can be minimized or prevented by using standard precautions consistently.
- HLD is the recommended method of final-processing for IUD services.
- Infection in IUD users is rare but is most often due to nonsterile IUD insertion technique.

JHPIEGO
USAID
Global Project

25

Slide 26

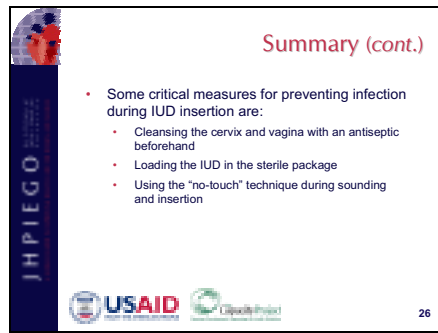

Summary (cont.)

- Some critical measures for preventing infection during IUD insertion are:
 - Cleansing the cervix and vagina with an antiseptic beforehand
 - Loading the IUD in the sterile package
 - Using the "no-touch" technique during sounding and insertion

JHPIEGO
USAID
Global Project

26

INTRAUTERINE CONTRACEPTIVE DEVICES (IUDs): CLIENT ASSESSMENT

Slide 1

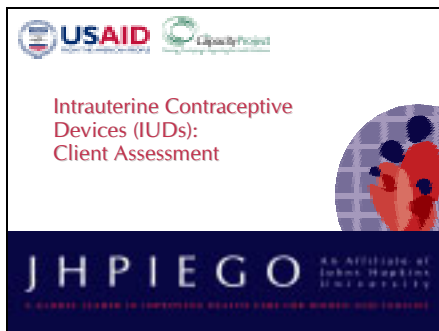

Slide 2

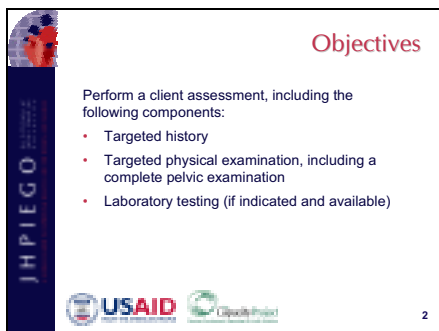

Slide 3

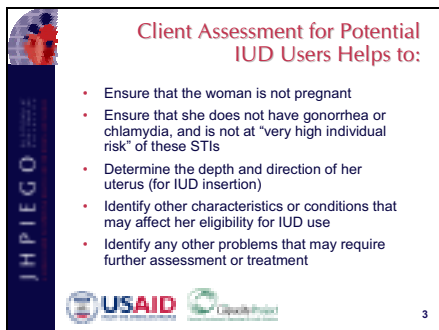

Slide 4

History

Contraceptive history/reproductive goals:

- Past experience/methods used
- Desire for children/more children or birth spacing
- Desire for long-term contraceptive protection

JHPIEGO
USAID
Dignity Project

4

Slide 5

History (cont.)

Menstrual history:

- Possibility of pregnancy/last menstrual period (LMP) (if not currently menstruating)
- Menstrual patterns (e.g., duration, amount, cramping/pain)

JHPIEGO
USAID
Dignity Project

5

Slide 6

History (cont.)

Obstetric history:

- Parity, gravida
- Past pregnancies and childbirths
 - Birth within last 4 weeks
- Past abortions (spontaneous and induced)
 - Abortion within last 4 weeks
- Signs/symptoms of infection (puerperal sepsis, post-septic abortion)

JHPIEGO
USAID
Dignity Project

6

Slide 7

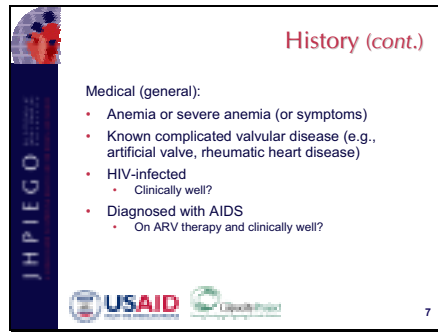

History (cont.)

Medical (general):

- Anemia or severe anemia (or symptoms)
- Known complicated valvular disease (e.g., artificial valve, rheumatic heart disease)
- HIV-infected
 - Clinically well?
- Diagnosed with AIDS
 - On ARV therapy and clinically well?

Logos: JHPIEGO, USAID, Quality Project

7

Slide 8

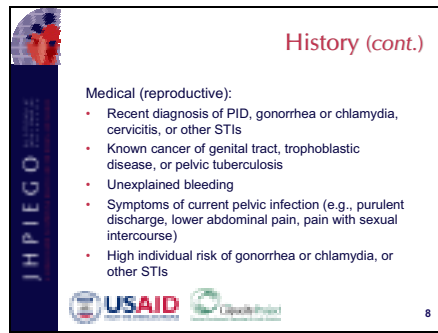

History (cont.)

Medical (reproductive):

- Recent diagnosis of PID, gonorrhea or chlamydia, cervicitis, or other STIs
- Known cancer of genital tract, trophoblastic disease, or pelvic tuberculosis
- Unexplained bleeding
- Symptoms of current pelvic infection (e.g., purulent discharge, lower abdominal pain, pain with sexual intercourse)
- High individual risk of gonorrhea or chlamydia, or other STIs

Logos: JHPIEGO, USAID, Quality Project

8

Slide 9

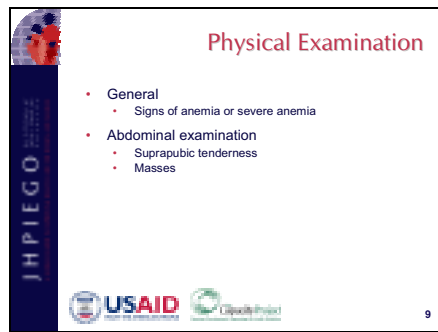

Physical Examination

- General
 - Signs of anemia or severe anemia
- Abdominal examination
 - Suprapubic tenderness
 - Masses

Logos: JHPIEGO, USAID, Quality Project

9

Slide 10

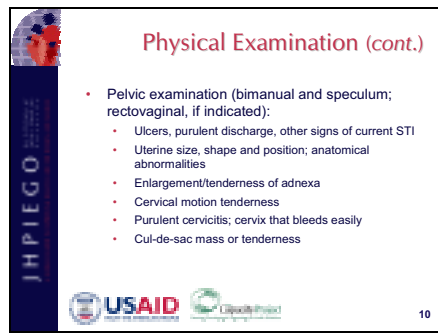

Physical Examination (cont.)

- Pelvic examination (bimanual and speculum; rectovaginal, if indicated):
 - Ulcers, purulent discharge, other signs of current STI
 - Uterine size, shape and position; anatomical abnormalities
 - Enlargement/tenderness of adnexa
 - Cervical motion tenderness
 - Purulent cervicitis; cervix that bleeds easily
 - Cul-de-sac mass or tenderness

USAID
Dignity Project

10

Slide 11



Laboratory Tests (if indicated and available)

- To rule out/diagnose gonorrhea or chlamydia
- To diagnose anemia/severe anemia
- To rule out pregnancy (in cases in which the pregnancy checklist does not apply)

Note: Although laboratory testing would be ideal in certain situations, it is not always available. Therefore, guidelines for providing the IUD generally do not depend on laboratory tests. The provider must weigh the advantages and disadvantages of providing the IUD on a case-by-case basis.

USAID
Dignity Project

11

Slide 12

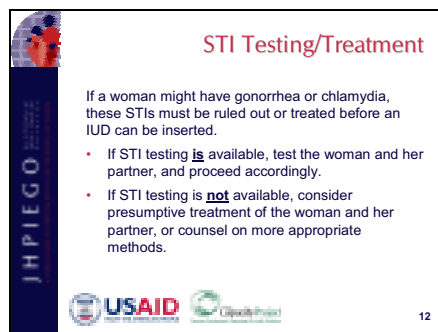

STI Testing/Treatment

If a woman might have gonorrhea or chlamydia, these STIs must be ruled out or treated before an IUD can be inserted.

- If STI testing **is** available, test the woman and her partner, and proceed accordingly.
- If STI testing is **not** available, consider presumptive treatment of the woman and her partner, or counsel on more appropriate methods.



USAID
Dignity Project

12

Slide 13

Determining Whether the IUD Should Be Inserted

- Pregnant or can not be reasonably certain she is not pregnant—IUD should not be inserted
- Never been pregnant—can generally use IUD, but slightly increased risk of expulsion



13

Slide 14

Determining Whether the IUD Should Be Inserted (cont.)

- Heavy, prolonged or painful periods—can generally use IUD, but symptoms may increase (a common side effect)
 - Inform the woman of these side effects
 - Provide careful counseling/reassurance
 - Discuss other contraceptive methods, if appropriate

Note: A hormone-releasing IUD, such as the Mirena, is an excellent option for women with heavy bleeding



 

14

Slide 15

Determining Whether the IUD Should Be Inserted (cont.)

- Birth within last 4 weeks—IUD should not be inserted
- Birth within last 48 hours—can generally use IUD (provided no infection) but insertion requires specially trained provider
- Immediately following first-trimester abortion—can use the IUD (provided no infection) (insertion after second-trimester abortion requires specially trained provider)

15

Slide 16

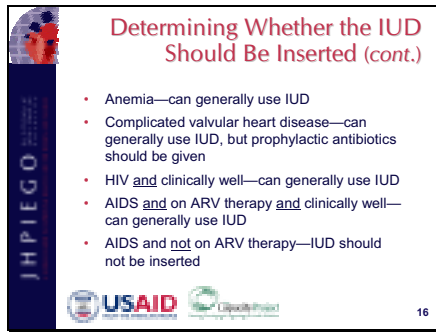

Determining Whether the IUD Should Be Inserted (cont.)

- Anemia—can generally use IUD
- Complicated valvular heart disease—can generally use IUD, but prophylactic antibiotics should be given
- HIV and clinically well—can generally use IUD
- AIDS and on ARV therapy and clinically well—can generally use IUD
- AIDS and not on ARV therapy—IUD should not be inserted

JHPIEGO
USAID
Dignity Project

16

Slide 17

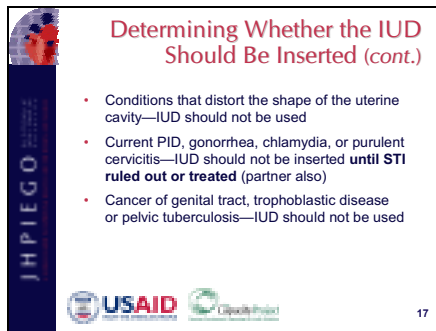

Determining Whether the IUD Should Be Inserted (cont.)

- Conditions that distort the shape of the uterine cavity—IUD should not be used
- Current PID, gonorrhea, chlamydia, or purulent cervicitis—IUD should not be inserted **until STI ruled out or treated** (partner also)
- Cancer of genital tract, trophoblastic disease or pelvic tuberculosis—IUD should not be used

JHPIEGO
USAID
Dignity Project

17

Slide 18

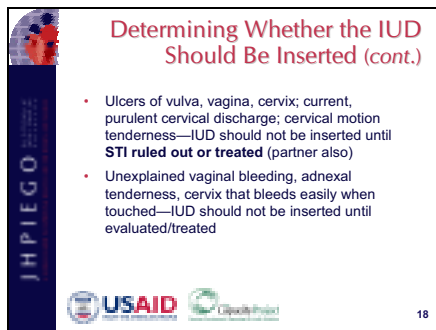

Determining Whether the IUD Should Be Inserted (cont.)

- Ulcers of vulva, vagina, cervix; current, purulent cervical discharge; cervical motion tenderness—IUD should not be inserted until **STI ruled out or treated** (partner also)
- Unexplained vaginal bleeding, adnexal tenderness, cervix that bleeds easily when touched—IUD should not be inserted until evaluated/treated

JHPIEGO
USAID
Dignity Project

18

Slide 19

Next Steps

- If there are no conditions that contraindicate IUD insertion at this time, the IUD can be inserted immediately after assessment

USAID Contraceptive Project

19

Slide 20

Next Steps (cont.)

If there is a condition that contraindicates IUD insertion at this time, do the following (as appropriate):

- Explain the reason to the woman
- Conduct further evaluation and treatment for any problems identified; refer if needed
- Treat woman's partner(s) when applicable
- Provide alternative method if IUD can never be used
- Provide back-up method, if needed (until IUD can be inserted or until alternative method begins working)
- Schedule a follow-up appointment for reassessment

USAID Contraceptive Project

20

Slide 21

Summary

- Careful assessment is needed to confirm that a woman is a good candidate for the IUD.
- If available and appropriate, the IUD can be inserted immediately after assessment.
- If the IUD can not be inserted at this time, an alternative method should be provided and appropriate follow-up arranged.

USAID Contraceptive Project

21

INTRAUTERINE CONTRACEPTIVE DEVICES (IUDs): INSERTION AND REMOVAL

Slide 1

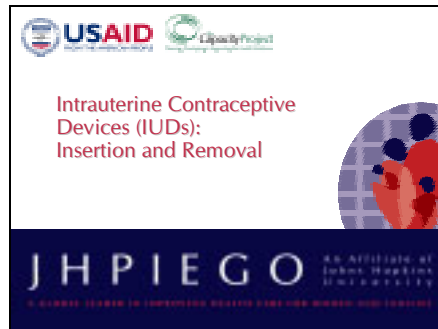

Slide 2

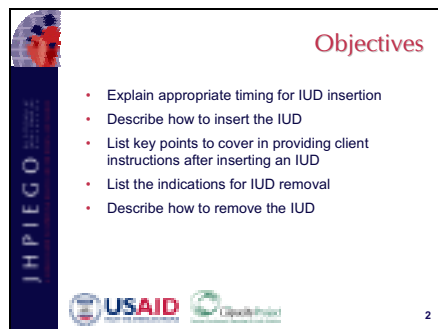

Slide 3

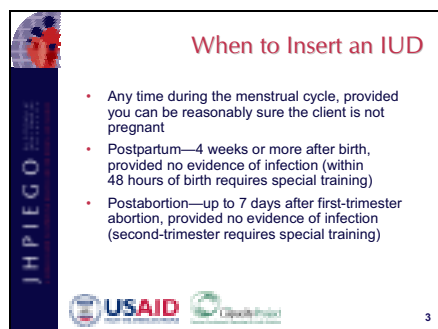

Slide 4

General Steps: Preinsertion

After the client has undergone appropriate assessment:

- Wash hands with soap and water; dry with clean, dry cloth or allow to air-dry
- Provide a brief overview of procedure to client
 - Prepare her for the possibility of pain
 - Ask her to tell you if she feels pain
- Place new/clean examination or high-level disinfected (or sterile) gloves on both hands

JHPIEGO
USAID
Dignity Project

4

Slide 5

General Steps: Preinsertion (cont.)

- Cleanse the cervix and vagina two times with antiseptic
- Sound the uterus (using "no-touch" technique and high-level disinfected [or sterile] instruments)
- Load the IUD in its sterile package

Note: The TCu 380A with Safe Load comes with a special device that makes it easier to load the IUD in the sterile package.

JHPIEGO
USAID
Dignity Project

5

Slide 6

General Steps: Preinsertion (cont.)

- Adjust the IUD depth-gauge to indicate uterine depth
- Remove the IUD from its package, ensuring that tip does not become contaminated

JHPIEGO
USAID
Dignity Project

6

Slide 7

General Steps: Insertion

- Carefully insert the IUD (using "no-touch" technique) until slight resistance is felt or depth-gauge comes in contact with cervix
- Release the IUD using the "withdrawal" technique
- Reposition the IUD at the top of the fundus by gently pushing the insertion tube
- Trim the IUD strings (3–4 cm from cervical os)

USAID Contraceptive Project

7

Slide 8

General Steps: Postinsertion

- Process instruments, gloves and other items according to recommended practices
- Properly dispose of waste
- Wash hands with soap and water; dry with clean, dry cloth or allow to air-dry
- Assess woman for nausea, cramping, dizziness/fainting
- Provide postinsertion education/counseling ("Key Messages for IUD Users"—next slides)

USAID Contraceptive Project

8

Slide 9

Key Messages for IUD Users

- The Copper T 380A protects against pregnancy for 12 years; the IUD should be removed/replaced at that time
- The IUD is effective immediately
- The IUD may be removed (by a trained provider) any time the client wishes for any reason
- IUDs do not provide protection against STIs (e.g., HBV, HIV/AIDS, gonorrhea, chlamydia); **use condoms also if at risk for STIs**



USAID Contraceptive Project

9

Slide 10

Key Messages for IUD Users (cont.)

- Menstrual changes are a common side effect:
 - Cramping and spotting during first few days after insertion
 - Increased menstrual bleeding/cramping and sometimes spotting/light bleeding between periods
 - Often lessen or go away within first few months
 - Generally not harmful
 - May be reduced by NSAIDs

10

Slide 11

Key Messages for IUD Users (cont.)

Warning signs for IUD Users (**PAINS**), which indicate a need to return to the clinic **immediately**:



P: Period-related problems or pregnancy symptoms

A: Abdominal pain or pain during intercourse

I: Infection (signs/symptoms or exposure to STI)

N: Not feeling well, fever, chills (other signs/symptoms of infection)

S: String problems—strings are shorter, longer or missing (or something hard felt in vaginal canal)



11

Slide 12

Key Messages for IUD Users (cont.)

- Check for possible IUD expulsion (first few months)
 - Check for IUD strings (after menses)
 - Check for expelled IUD on pad/cloth/tampon and in latrine (during menses)

Note: IUD expulsion is uncommon. When it does occur, it is most common during the first few months after insertion, and in women who are nulliparous, have heavy menstrual bleeding, or had an IUD inserted immediately postpartum or following second-trimester abortion.

12

Slide 13

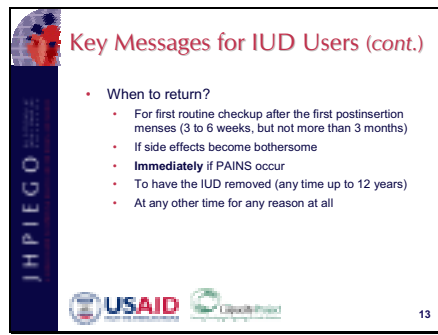

Key Messages for IUD Users (cont.)

- When to return?
 - For first routine checkup after the first postinsertion menses (3 to 6 weeks, but not more than 3 months)
 - If side effects become bothersome
 - **Immediately** if PAINS occur
 - To have the IUD removed (any time up to 12 years)
 - At any other time for any reason at all

JHPIEGO
USAID
Contraceptive Project

13

Slide 14

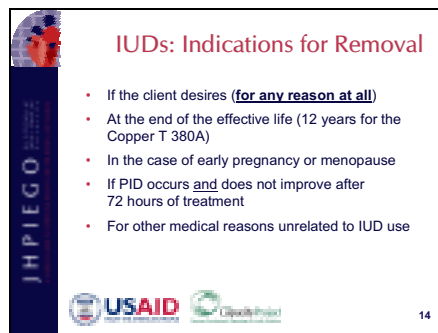

IUDs: Indications for Removal

- If the client desires (**for any reason at all**)
- At the end of the effective life (12 years for the Copper T 380A)
- In the case of early pregnancy or menopause
- If PID occurs **and** does not improve after 72 hours of treatment
- For other medical reasons unrelated to IUD use

JHPIEGO
USAID
Contraceptive Project

14

Slide 15

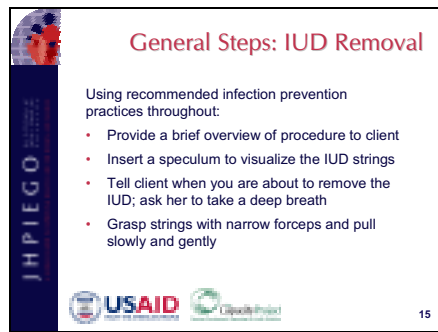

General Steps: IUD Removal

Using recommended infection prevention practices throughout:

- Provide a brief overview of procedure to client
- Insert a speculum to visualize the IUD strings
- Tell client when you are about to remove the IUD; ask her to take a deep breath
- Grasp strings with narrow forceps and pull slowly and gently

JHPIEGO
USAID
Contraceptive Project

15

Slide 16

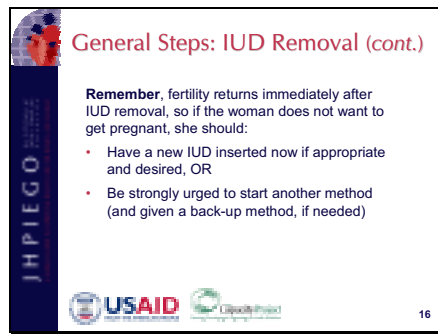

General Steps: IUD Removal (cont.)

Remember, fertility returns immediately after IUD removal, so if the woman does not want to get pregnant, she should:

- Have a new IUD inserted now if appropriate and desired, OR
- Be strongly urged to start another method (and given a back-up method, if needed)

JHPIEGO

USAID **Global Project**

16

Slide 17

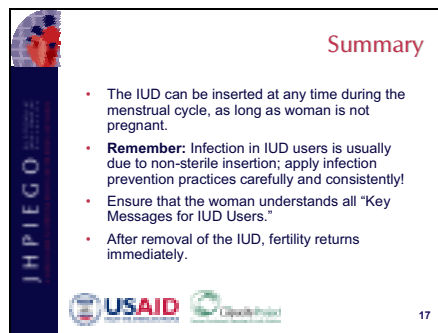

Summary

- The IUD can be inserted at any time during the menstrual cycle, as long as woman is not pregnant.
- **Remember:** Infection in IUD users is usually due to non-sterile insertion; apply infection prevention practices carefully and consistently!
- Ensure that the woman understands all "Key Messages for IUD Users."
- After removal of the IUD, fertility returns immediately.

JHPIEGO

USAID **Global Project**

17

INTRAUTERINE CONTRACEPTIVE DEVICES (IUDs): FOLLOW-UP CARE AND MANAGEMENT OF POTENTIAL PROBLEMS

Slide 1

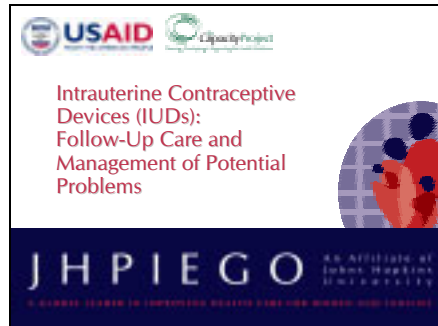

Slide 2

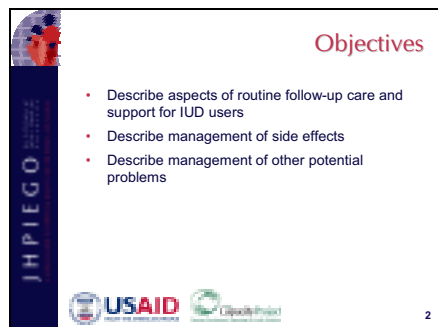

Slide 3

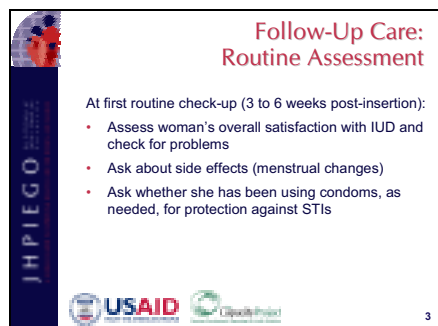

Slide 4

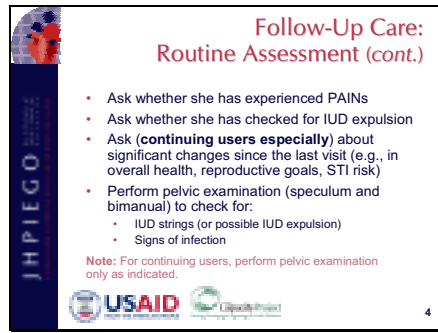

Follow-Up Care: Routine Assessment (cont.)

- Ask whether she has experienced PAINs
- Ask whether she has checked for IUD expulsion
- Ask (**continuing users especially**) about significant changes since the last visit (e.g., in overall health, reproductive goals, STI risk)
- Perform pelvic examination (speculum and bimanual) to check for:
 - IUD strings (or possible IUD expulsion)
 - Signs of infection

Note: For continuing users, perform pelvic examination only as indicated.

JHPIEGO | USAID | Contraceptive Project

4

Slide 5



Follow-Up Care: Routine Support

- Address any questions and concerns
- Provide reassurance and support for menstrual changes if needed
- Reinforce key messages:
 - Warning signs (PAINs)
 - Need for use of condoms to protect against STIs
 - Need to check for IUD expulsion, as appropriate
 - When to return to clinic
- Schedule return visit for one year

JHPIEGO | USAID | Contraceptive Project

5

Slide 6

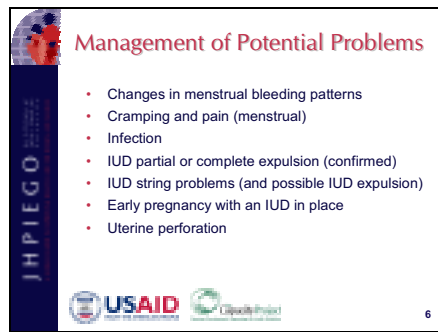

Management of Potential Problems

- Changes in menstrual bleeding patterns
- Cramping and pain (menstrual)
- Infection
- IUD partial or complete expulsion (confirmed)
- IUD string problems (and possible IUD expulsion)
- Early pregnancy with an IUD in place
- Uterine perforation

JHPIEGO | USAID | Contraceptive Project

6

Slide 7

Changes in Menstrual Bleeding Patterns

- Find out more about symptoms
- Conduct further evaluation/treatment if:
 - Bleeding is twice as much or twice as long as usual
 - Changes persist beyond 3–6 months and a gynecologic problem is suspected
 - Changes began long after IUD insertion

7

Slide 8

Changes in Menstrual Bleeding Patterns (cont.)

- If changes are accompanied by anemia:
 - Provide iron supplementation
 - Counsel on local, iron-rich foods
- If changes are accompanied by severe anemia:
 - Counsel on methods that may be more appropriate

8

Slide 9

Changes in Menstrual Bleeding Patterns (cont.)

- If changes are within normal range:
 - Provide reassurance that symptoms often subside, and do not usually indicate a problem
 - Encourage prophylactic medication (an NSAID such as ibuprofen: 200–400 mg every 4–6 hours) a day before and during menses

9

Slide 10

Cramping and Pain (Menstrual)

- Find out more about symptoms
- Conduct additional assessment as appropriate to rule out other possible causes of symptoms (e.g., infection, partial IUD expulsion, uterine perforation, pregnancy/ectopic pregnancy)

10

Slide 11

Cramping and Pain (Menstrual) (cont.)

- If other possible causes are ruled out and symptoms are **severe**, remove the IUD
 - If IUD is improperly placed or abnormal looking, advise woman that new IUD may solve problem
 - If IUD is properly placed and normal looking, counsel woman on other contraceptive methods

11

Slide 12

Cramping and Pain (Menstrual) (cont.)

- If other possible causes are ruled out and symptoms are **not severe**:
 - Provide reassurance that symptoms often subside, and do not usually indicate a problem
 - Encourage prophylactic medication (an NSAID such as ibuprofen: 200–400 mg every 4–6 hours) a day before and during menses

12

Slide 13

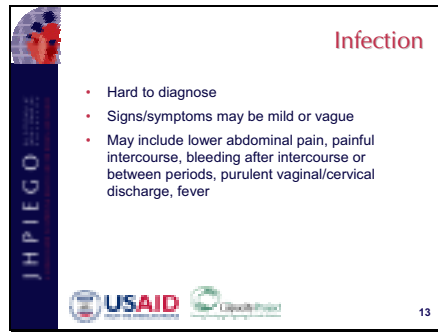

Infection

- Hard to diagnose
- Signs/symptoms may be mild or vague
- May include lower abdominal pain, painful intercourse, bleeding after intercourse or between periods, purulent vaginal/cervical discharge, fever

13

Slide 14

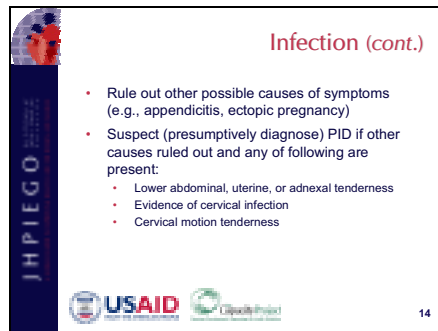

Infection (cont.)

- Rule out other possible causes of symptoms (e.g., appendicitis, ectopic pregnancy)
- Suspect (presumptively diagnose) PID if other causes ruled out and any of following are present:
 - Lower abdominal, uterine, or adnexal tenderness
 - Evidence of cervical infection
 - Cervical motion tenderness

14

Slide 15

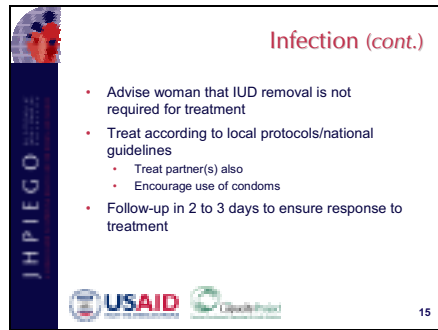

Infection (cont.)

- Advise woman that IUD removal is not required for treatment
- Treat according to local protocols/national guidelines
 - Treat partner(s) also
 - Encourage use of condoms
- Follow-up in 2 to 3 days to ensure response to treatment

15

Slide 16

IUD Partial or Complete Expulsion (Confirmed)

- May not be noticed
- May be associated with irregular bleeding, pain with intercourse, unusual discharge, postcoital bleeding or longer/missing strings
- Rule out pregnancy and infection

USAID Contraceptive Project 16

Slide 17

IUD Partial or Complete Expulsion (Confirmed) (cont.)

- If complete expulsion confirmed (seen by woman or by provider on X-ray/ultrasound):
 - Replace IUD now, if desired and appropriate; OR
 - Provide alternative method (and back-up, if needed)

USAID Contraceptive Project 17

Slide 18

IUD Partial or Complete Expulsion (Confirmed) (cont.)

- If partial expulsion confirmed (felt/seen by woman or provider in cervix or vagina):
 - Remove IUD
 - If IUD seems embedded in cervical wall, refer woman to specially trained provider for IUD removal
 - Replace IUD now, if desired and appropriate; OR
 - Provide alternative method (and back-up, if needed)

USAID Contraceptive Project 18

Slide 19

**IUD String Problems:
Partner Complaints**

- Discuss client/couple's concerns
- Provide reassurance (strings cut too short, IUD still working, not harmful)
- If bothersome:
 - Cut strings shorter (but explain that she will not be able to check them), OR
 - Insert new IUD and ensure that strings are not cut too short

JHPIEGO
USAID
Dignity Project

19

Slide 20

**IUD String Problems:
Missing Strings**

- Possible causes: IUD expulsion or malposition, uterine perforation, ascension of strings
- **FIRST**, rule out pregnancy
- Try to locate strings using cervical brush or narrow forceps
 - If strings are located, leave IUD in place if desired
 - If strings are not located, do X-ray (or ultrasound) to see whether IUD is in place

JHPIEGO
USAID
Dignity Project

20

Slide 21

**IUD String Problems:
Missing Strings (cont.)**

- If IUD is located in the uterus, leave IUD in place if desired
- If IUD is located in the uterus but woman wants it removed, refer the woman for IUD removal by a qualified provider

JHPIEGO
USAID
Dignity Project

21

Slide 22

Early Pregnancy with an IUD in Place

- Rule out ectopic pregnancy
- Determine whether woman wants to continue pregnancy
- If woman elects **not to continue** pregnancy:
 - Obtain formal consent
 - If strings are visible, remove IUD immediately (do not wait until procedure)
 - If strings are not visible, refer the woman for IUD removal by a qualified provider

USAID Contraceptive Project

22

Slide 23

Early Pregnancy with an IUD in Place (cont.)

- If woman elects to **continue** pregnancy, counsel woman about risks:
 - Increased risk of septic abortion and preterm labor if IUD kept in place
 - Only slightly increased risk of miscarriage if IUD removed early

USAID Contraceptive Project

23

Slide 24

Early Pregnancy with an IUD in Place (cont.)

- If woman agrees to have IUD removed:
 - Obtain formal consent
 - If strings are visible, remove IUD immediately
- If strings are not visible or woman does not want IUD removed:
 - Obtain an ultrasound to verify IUD location in the uterus
 - Closely monitor throughout pregnancy
 - Remove IUD at delivery

USAID Contraceptive Project

24

Slide 25

Uterine Perforation

- Rare: less than 1 in 1000
- Result of poor insertion technique
- Common signs (during insertion):
 - Sudden loss of resistance during sounding or insertion
 - Uterine depth greater than expected
 - Unexplained pain
- Rare signs (during insertion): pain, vaginal bleeding, rapid pulse

USAID Contraceptive Project 25

Slide 26

Uterine Perforation (cont.)

- If any of these signs/symptoms occur, stop immediately
- Attempt removal of sound or IUD
 - If resistance is encountered or complete perforation is suspected (rare), refer for laparoscopy for further evaluation and removal
- Monitor woman's vital signs and level of discomfort until stable

USAID Contraceptive Project 26

Slide 27

Uterine Perforation (cont.)

- For uterine perforation discovered (by X-ray/ultrasound) a **few days/weeks** after IUD insertion:
 - For partial perforations, refer to specially trained provider for IUD removal
 - For complete perforations, refer to surgeon qualified to perform laparoscopy and laparotomy for evaluation and IUD removal

USAID Contraceptive Project 27

Slide 28

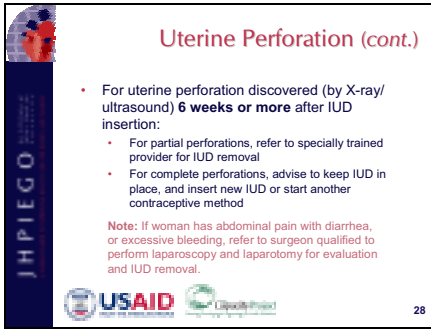

Uterine Perforation (cont.)

- For uterine perforation discovered (by X-ray/ultrasound) **6 weeks or more** after IUD insertion:
 - For partial perforations, refer to specially trained provider for IUD removal
 - For complete perforations, advise to keep IUD in place, and insert new IUD or start another contraceptive method

Note: If woman has abdominal pain with diarrhea, or excessive bleeding, refer to surgeon qualified to perform laparoscopy and laparotomy for evaluation and IUD removal.

JHPIEGO
USAID
Quality Project

28

Slide 29



Summary

- Quality follow-up care helps maintain client satisfaction
- Providing reassurance and treatment for side effects encourages continuation of method
- Recognizing and managing problems (or referring the woman when appropriate) is an essential element of follow-up care/support

JHPIEGO
USAID
Quality Project

29

SECTION TWO: GUIDE FOR TRAINERS

MODEL COURSE OUTLINE	1
PRECOURSE QUESTIONNAIRE	
Using the Individual and Group Assessment Matrix.....	12
Precourse Questionnaire Answer Key.....	13
EXERCISE: HOW PEOPLE LEARN	
Session Objective.....	15
Enabling Objectives.....	15
Comparison of Formal (School) and Practical (Hands-On) Methods of Learning	15
Stages of Learning Clinical Skills	18
Summary	19
Activity 1: Loading the TCu 380A IUD in a Sterile Package or Building a Paper Box	21
Activity 2: The Number Game	28
Activity 3: The Nine Dots Puzzle	37
PRECOURSE ASSESSMENT CHECKLIST	
Using the Checklist.....	40
Precourse Assessment Checklist for IUD Counseling and Clinical Skills.....	41
EXERCISE: WHO HAS AIDS?	43
EXERCISE 1 KEY: WHO ELIGIBILITY CRITERIA	44
EXERCISE 2 KEY: COUNSELING IUD USERS	46
EXERCISE 3 KEY: INFECTION PREVENTION	47
EXERCISE 4 KEY: CLIENT ASSESSMENT	48
EXERCISE 5 KEY: IUD INSERTION AND REMOVAL	50
EXERCISE 6 KEY: QUIZ	51
MIDCOURSE QUESTIONNAIRE	
Using the Questionnaire	53
Midcourse Questionnaire.....	54
Midcourse Questionnaire Answer Sheet	59
Midcourse Questionnaire Answer Key	61
CHECKLIST FOR IUD COUNSELING AND CLINICAL SKILLS	
Using the Checklist.....	65
Checklist for IUD Counseling and Clinical Skills (Adapted for the Regular Copper T 380A)	67
Checklist for IUD Counseling and Clinical Skills (Adapted for the Safe Load Copper T 380A)	70
Checklist for IUD Counseling and Clinical Skills (Adapted for the Multiload Cu375)	73

MODEL COURSE OUTLINE

The course outline presented here is a model plan of the training to be delivered. It presents enabling objectives needed to accomplish the participant learning objectives described in the course syllabus. For each enabling objective, there are suggestions regarding appropriate learning activities and resources and materials needed. The trainer may develop other practice activities and prepare case studies, role plays, or other learning situations that are specific to the country or group of participants.

The course outline is divided into four columns.

- **Time.** This section of the outline indicates the approximate amount of time to be devoted to each learning activity.
- **Objectives/Activities.** This column lists the enabling objectives and learning activities. Because the objectives outline the sequence of training, the objectives are presented here in order. The combination of the objectives and activities (introductory activities, small-group exercises, clinical practice, breaks, etc.) outlines the **flow** of training.
- **Training/Learning Methods.** This column describes the various methods, activities, and strategies to be used to deliver the content and skills related to each enabling objective.
- **Resources/Materials.** The fourth column in the course outline lists the resources and materials needed to support the learning activities.

Note that the course schedule is based on the course outline. As such, changes or modifications to one should be reflected in the other.

Note: There are several different types of IUDs available on the market. Two commonly available IUDs are the Copper T 380A (regular and with Safe Load) and the Multiload Cu375, both copper-bearing IUDs. This learning package focuses on the knowledge and skills needed to provide services for the Copper T 380A; however, supplemental materials for Multiload Cu375 are also provided in the Trainer's Notebook.

MODEL IUD COURSE OUTLINE (STANDARD COURSE: 6 DAYS)			
TIME	OBJECTIVES/ACTIVITIES	TRAINING/LEARNING METHODS	RESOURCES/MATERIALS
Session One: Day 1, AM			
20 minutes	Objective: Identify participant expectations.	Opening: Introduce trainers and ask participants to introduce themselves and summarize their experience with providing IUDs. Identify participant expectations and tell participants which expectations will be addressed during this course.	
20 minutes	Objective: Describe course goals and objectives, course materials, and schedule.	Overview of Course: Review the course materials and schedule with the group. Tell them that in order to ensure that they get the most clinical practice possible, you will: <ul style="list-style-type: none"> Assess their current knowledge and skills; and Adjust the training (e.g., schedule, content) accordingly. 	IUD Reference Manual (1 per participant) IUD Course Handbook (1 per participant)
45 minutes	Objective: Assess participants' precourse knowledge.	Precourse Questionnaire: Complete precourse questionnaire and grade it as a group.	Handbook: Precourse Questionnaire
45 minutes	Objectives: <ul style="list-style-type: none"> Influence participants' attitudes toward the advantages of the IUD. Provide latest technical information on the IUD. 	Lecture/Discussion: Share presentation on Chapter 1. This presentation includes a small group exercise that is explained on one of the slides. Assessment: While one trainer is presenting, the other should fill out the individual and group assessment matrix.	Handbook: Individual and Group Assessment Matrix Other: Presentation graphics 1
20 minutes	Objective: Identify individual and group learning needs.	Discussion: Post matrix and share with the group. Discuss areas that will need extra focus during the course. Assessment: Clinical trainers complete precourse assessment checklist for each participant and review results individually.	
60 minutes	Objective: Provide participants with general counseling skills.	Brainstorming: Begin session by asking participants why counseling is important. List on a flipchart. Spend up to 10 minutes discussing this. Lecture/demonstration: Share presentation on Chapter 2. In the middle, demonstrate the GATHER counseling approach when indicated in the slides. Have participants follow along with the IUD counseling learning guide. Then finish the presentation with a focus on client instructions.	Handbook: Learning Guide for Counseling Skills Other: Presentation graphics 2
Equipment for course:			
<ul style="list-style-type: none"> Blackboard/chalk (or flipchart/marker pens) Projection unit and laptop 		<ul style="list-style-type: none"> Video player and monitor Handheld uterine models 	<ul style="list-style-type: none"> IUD insertion/removal kits Copper T 380A IUDs in sterile packages

MODEL IUD COURSE OUTLINE (STANDARD COURSE: 6 DAYS)			
TIME	OBJECTIVES/ACTIVITIES	TRAINING/LEARNING METHODS	RESOURCES/MATERIALS
Session Two: Day 1, PM			
2 hours 15 minutes	Objective: Assess participants' current skill level in key areas.	<p>Assessment (see Note below): Set up three different skills stations:</p> <ol style="list-style-type: none"> 1. Pelvic examination 2. IUD insertion, including necessary IP steps 3. "No-touch" technique of manipulating the IUD through its sterile packet <ul style="list-style-type: none"> • Have a copy of the appropriate learning guide at each station. • Divide the group into three smaller groups. Each group will take turns rotating through the station, spending about 45 minutes at each one. • Tell the participants (1) to use the learning guides and take notes, especially for skills areas that are most difficult for them; (2) that you will review these with them later. • Plan a time to review learning guides and notes with each participant, advising them on which areas to focus their study and practice. <p>Note: You may need an extra trainer for this afternoon because you should have a trainer at each station.</p>	<p>Handbook: Learning Guide for IUD Clinical Skills</p> <p>Other: Two ZOE models, an IUD kit, needed IP supplies, packets of the IUD for loading in the sterile package</p>
30 minutes	Objective: Review use and care of anatomical models	Discussion: Review the different cervices available for use and different uses of the model. Demonstrate how to remove the skin and how to change the cervices. Demonstrate care and maintenance for the model.	Handbook: Instructions for Using ZOE Gynecologic Simulators
15 minutes	Closing	Review: Review areas that you will focus on based on your assessment. Assign Chapters 1–5 and Exercise 1 as homework. Tell the group you will be reviewing both on the next day.	
Reading Assignment: Reference Manual: Chapters 1–5 and FHI's Quick Reference Chart (end of the manual).			

MODEL IUD COURSE OUTLINE (STANDARD COURSE: 6 DAYS)			
TIME	OBJECTIVES/ACTIVITIES	TRAINING/LEARNING METHODS	RESOURCES/MATERIALS
Session Three: Day 2, AM			
15 minutes	Objective: Review day's scheduled activities.	Warm-up Exercise Overview of day's scheduled activities	
30 minutes	Objective: Review Exercise 1.	Review: Either ask participants to trade with their neighbor to grade these, or go through them as a group. Ask the group whether there are any questions they disagree with or don't understand.	Notebook: Exercise 1
105 minutes	Objective: Observe different aspects of clinical IUD services.	Tour of Clinical Facilities: You may wish to divide the group into smaller groups to observe each of the following: counseling/education, method provision, IP practices and facilities. Note: If possible, demonstrate these clinical activities with clients' permission and allow participants to observe.	
30 minutes	Objective: Review clinic practices.	Discussion: Discuss participants' experience in the clinic. Which skills are performed to standard? Which are not? What did they learn? How did what they see compare to their own practice?	
30 minutes	Objective: Observe demonstration of pelvic examination, IUD insertion (including IP), and removal.	Demonstration: Demonstrate IUD insertion from abdominal exam all the way through IUD insertion and removal. Use a model and handheld uterus to show participants the whole procedure from beginning to end. Instruct them to follow along with their learning guides.	Handbook: Learning Guide for IUD Clinical Skills Other: One each—ZOE pelvic and handheld uterine models
Session Four: Day 2, PM			
45 minutes	Objective: Learn to manipulate the IUD in the sterile package.	Demonstration and Practice: Demonstrate loading the Copper T in the sterile package. Provide participants with time to practice in pairs until they are comfortable.	Handbook: Learning Guide for IUD Clinical Skills Other: IUD
45 minutes	Objective: Review recommended IP practices to reduce risks to providers and clients.	Presentation: Use Exercise 2 to ask the group questions about IP. Share presentation on Chapter 3, highlighting any information that has not already been covered. You may also use this time to focus on identified areas of weakness in IP.	Reference Manual: Chapter 3 Notebook: Exercise 2 Other: IUD IP training video (JHPIEGO); Presentation graphics 3
The participants are divided into two groups, with five to six participants per trainer. Group 1 and Group 2 will exchange activities. Each participant must demonstrate competency in counseling (role play by participants or with volunteers) and in the standard methods for IUD insertion and removal using models before beginning Guided Clinical Activities with Clients. GROUPS 1 AND 2 SHOULD SWITCH ACTIVITIES AFTER AN HOUR.			

MODEL IUD COURSE OUTLINE (STANDARD COURSE: 6 DAYS)			
TIME	OBJECTIVES/ACTIVITIES	TRAINING/LEARNING METHODS	RESOURCES/MATERIALS
120 minutes	<p>Group 1 Objective: Practice general family planning counseling and method-specific counseling in a simulated clinic setting.</p>	<p>Group 1: Guided Counseling Activities Working in pairs, participants use role plays from Exercise 3 to practice counseling each other. You may randomly assign the role plays or allow them to choose the one that most interests them. Participants should assess each other's performance using Learning Guide for IUD Counseling Skills.</p>	<p>Reference Manual: Chapter 2</p> <p>Handbook: Learning Guide for IUD Counseling Skills</p> <p>Notebook: Exercise 3</p>
	<p>Group 2 Objective: Practice standard IUD insertion and removal methods in a simulated clinical setting and satisfactorily demonstrate:</p> <ul style="list-style-type: none"> ● Performing the screening pelvic exam ● Sounding the uterus ● Manipulating the IUD in sterile package ● IUD insertion ● IUD removal ● Use of recommended IP practices 	<p>Group 2: Guided Clinical Skills Activities with Models Working in pairs, participants perform the following activities, and assess each other's performance using Learning Guide and Practice Checklist for IUD Clinical Skills.</p> <p>Handheld Model: Practice inserting the IUD using the withdrawal technique and IUD removal.</p> <p>ZOE Pelvic Model: Practice pelvic exam (speculum and bimanual), placing the cervical tenaculum, sounding the uterus, inserting the IUD, releasing the IUD and removing the IUD.</p>	<p>Reference Manual: Chapter 5, FHI's Quick Reference Chart (end of the manual)</p> <p>Handbook: Learning Guide and Practice Checklist for IUD Clinical Skills</p> <p>Other: 1 ZOE pelvic model per 2–3 participants and 1 handheld uterine model per participant; participants should use IUDs from Session Two; extra IUDs in sterile packages for demonstration and practice</p>
5 minutes	Closing	<p>Review: Review areas that were confusing or required clarification from today's activities. Assign Chapter 6 and Appendices A–D as homework.</p>	
Reading Assignment: Reference Manual: Chapter 6, Appendices A–D			

MODEL IUD COURSE OUTLINE (STANDARD COURSE: 6 DAYS)			
TIME	OBJECTIVES/ACTIVITIES	TRAINING/LEARNING METHODS	RESOURCES/MATERIALS
Session Five: Day 3, AM			
15 minutes	Objective: Review day's scheduled activities.	Warmup Exercise	
45 minutes	Objective: Provide participants with information about skills needed to perform client assessment and screening.	Discussion and Presentation: Begin by brainstorming with participants what they would include in client screening and assessment for an IUD. Write their responses on a flipchart. Identify missing information by sharing the presentation on Chapter 4.	Reference Manual: Chapter 4 Other: Presentation graphics 4
Those participants who were observed as competent in either counseling or IUD insertion may go to clinic for supervised practice either in IP, in counseling, or with clients for IUD insertion. (For guidance on Guided Clinical Practice with Trainers, see Session 7.) Those who need further practice should be divided up into groups to practice either counseling, IP, or IUD insertion or removal.			
150 minutes	Objectives: Provide participants opportunity to demonstrate competency in performing assessment, screening and service provision: <ul style="list-style-type: none"> • Providing counseling (including method-specific counseling) • Performing client assessments, including reproductive history, focused physical examination and laboratory tests (if indicated and available) • Inserting and removing IUDs • Providing postinsertion counseling and instructions on possible side effects and other problems • Practicing the above-described skills with real clients OR through role plays or using models as appropriate 	Clinic Practice: Those who are not yet competent in counseling in a role play or in IUD insertion or removal with models should practice in small groups, receive feedback, and be assessed as competent before practicing with clients. Those who are more advanced may practice with clients in the areas in which they have achieved competency in simulation.	Handbook: Learning Guide and Practice Checklist for IUD Clinical Skills Other: 1 ZOE pelvic model per 2–3 participants and 1 handheld uterine model per participant; participants should use IUDs from Session Two; extra IUDs in sterile packages for demonstration and practice

MODEL IUD COURSE OUTLINE (STANDARD COURSE: 6 DAYS)			
TIME	OBJECTIVES/ACTIVITIES	TRAINING/LEARNING METHODS	RESOURCES/MATERIALS
Session Six: Day 3, PM			
30 minutes	Objective: Review selected cases from morning session.	Clinical Conference	
60 minutes	Objective: Provide participants with information about skills needed to perform client assessment and screening.	Exercise and Discussion: <ul style="list-style-type: none"> • Divide the group into pairs. Give them 30 minutes to complete Exercise 4, using their manual. Then review the answers and discuss as a group. • Share the portion of Appendix B that deals with ensuring that the client is not pregnant. Based on this, describe some different scenarios and ask participants whether the woman would/would not be a suitable candidate for the IUD. 	Reference Manual: Chapter 4, Appendix B Notebook: Exercise 4
30 minutes	Objective: Review key steps in IUD insertion.	Discussion: Review the IUD insertion flow chart with the group. Ask questions that encourage them to use the flow chart as a decision-making tool. Exercise: Divide the group into teams. Ask questions from Exercise 5 (one by one), and give whichever participant raises his/her hand first the chance to respond. You can assign points to the team whose participants have respond correctly: 3 points if right first try, and 2 points if right after someone else failed. Use Chapter 5 to supplement any information needed.	Reference Manual: IUD insertion flow chart (Chapter 1); Chapter 5 (as needed) Notebook: Exercise 5
30 minutes	Objective: Describe the process of assessing for high individual risk of STIs.	Discussion: Review the IUD client assessment checklist, focus discussion on how the term “very high individual risk” is defined. Discuss the various ways to assess individual risk of STIs, using both the manual and the checklist. Highlight the need for weighing these risks against that of unintended pregnancy, as well as providers’ tendency to overestimate risks. Spend some time looking at the use of questions as a self-assessment tool.	Reference Manual: Chapter 4, Appendix B
30 minutes	Objective: Review progress so far.	Discussion: Refer participants to their learning objectives in their handbooks. Discuss which areas require focus for the rest of the training in order to meet the objectives. Assign participants Exercise 6 as homework.	Notebook: Exercise 6

MODEL IUD COURSE OUTLINE (STANDARD COURSE: 6 DAYS)			
TIME	OBJECTIVES/ACTIVITIES	TRAINING/LEARNING METHODS	RESOURCES/MATERIALS
Session Seven: Day 4, AM			
20 minutes	Objective: Review day's scheduled activities.	Review: Review the answers to Exercise 6, and discuss any questions or content that was not understood.	
180 minutes	Objectives: Provide participants opportunity to demonstrate competency (in the following skills areas) with clients under the supervision of trainers: <ul style="list-style-type: none"> • Providing counseling (including method-specific counseling) • Performing client assessments, including reproductive history, focused physical examination and laboratory tests (if indicated and available) • Inserting and removing IUDs, applying IP practices throughout • Providing postinsertion counseling and instructions on possible side effects and other problems 	Assessment: Participants assess each other's performance using the Practice Checklist. If participants feel ready and wish to be assessed, they should let the trainers know; the trainers will assess participants' performance using the Checklist.	Handbook: Practice Checklist for IUD Counseling and Clinical Skills
Session Eight: Day 4, PM			
30 minutes	Objective: Review selected cases from morning session.	Clinical Conference	
60 minutes	Objectives: <ul style="list-style-type: none"> • Review the guidelines for decontaminating, cleaning, high-level disinfecting and sterilizing equipment where you work. • Describe the steps in handling contaminated wastes. 	Demonstration/Discussion: Discuss how current practices are different from IP standards in the training. Review handling contaminated wastes. Demonstrate or review any topics in IP that you have noted are weak in either the participants' knowledge or the clinic's practice. If needed, use the presentation on Chapter 3 to highlight important issues.	Reference Manual: Chapter 3 Other: Presentation graphics 3

MODEL IUD COURSE OUTLINE (STANDARD COURSE: 6 DAYS)			
TIME	OBJECTIVES/ACTIVITIES	TRAINING/LEARNING METHODS	RESOURCES/MATERIALS
105 minutes	<p>Objectives:</p> <ul style="list-style-type: none"> Observe demonstration of insertion and removal using another type of IUD. Learn to manipulate the IUD in the sterile package. Practice on pelvic model inserting and removing IUD. 	<p>Divide in groups of 2–3 and on ZOE Pelvic Model Practice: Practice pelvic exam (speculum and bimanual), placing the cervical tenaculum, sounding the uterus, inserting the IUD and removing the IUD.</p>	<p>Reference Manual: Chapter 5, Appendices C and D</p> <p>Handbook: Learning Guide and Practice Checklist for IUD Clinical Skills</p> <p>Other: 1 ZOE pelvic model per 2–3 participants and 1 handheld uterine model per participant; participants should use IUDs from Session Two; extra IUDs in sterile packages for demonstration and practice</p>
15 minutes		<p>Remind participants that the Midcourse Questionnaire is tomorrow afternoon. Review key information or areas that were confusing or required clarification from today's activities.</p>	
Session Nine: Day 5, AM			
15 minutes	<p>Objective: Review day's scheduled activities.</p>	<p>Warmup Exercise</p>	
195 minutes	<p>Objectives: Provide participants opportunity to demonstrate competency (in the following skills areas) with clients under the supervision of trainers:</p> <ul style="list-style-type: none"> Providing counseling (including method-specific counseling) Performing client assessments, including reproductive history, focused physical examination and laboratory tests (if indicated and available) Inserting and removing IUDs, applying IP practices throughout Providing postinsertion counseling and instructions on possible side effects and other problems 	<p>Clinical Practice/Assessment:</p> <p>Participants perform the following guided clinical activities:</p> <ul style="list-style-type: none"> Counseling clients Client assessment IUD insertion with clients IUD removal with clients (if available) Followup care Management of side effects and other problems <p>Participants assess each other's performance using the Practice Checklist for IUD Counseling and Clinical Skills. Trainers assess the performance and complete a Checklist for IUD Counseling and Clinical Skills for each participant.</p>	<p>Handbook: Practice Checklist for IUD Counseling and Clinical skills</p>

MODEL IUD COURSE OUTLINE (STANDARD COURSE: 6 DAYS)			
TIME	OBJECTIVES/ACTIVITIES	TRAINING/LEARNING METHODS	RESOURCES/MATERIALS
Session Ten: Day 5, PM			
45 minutes	Objective: Assess participants' knowledge.	Midcourse Questionnaire	Notebook: Midcourse Questionnaire
60 minutes	Objective: Practice on pelvic model inserting and removing IUD	Classroom Practice: Divide in groups of 2–3 and on ZOE Pelvic Model practice pelvic exam and IUD insertion—placing the cervical tenaculum, sounding the uterus, inserting the IUD and removing the IUD.	Handbook: Learning Guide and Practice Checklist for IUD Clinical Skills Other: 1 ZOE pelvic model per 2–3 participants and 1 handheld uterine model per participant; participants should use IUDs from previous sessions
60 minutes	Objective: Apply principles of quality assurance to clinic services.	Discussion: Discuss aspects of quality services. Spend time reviewing the performance standards for IUD services. Activity: Divide the group into smaller groups; groups will take turns practicing using the standards to assess the clinic or services in simulation. Discussion: Discuss their experiences with using the performance standards tool. Did they find it useful? How would they use it in their own practice?	Other: IUD performance standards
15 minutes	Closing	Review: Review areas that were confusing or required clarification from today's activities.	

MODEL IUD COURSE OUTLINE (STANDARD COURSE: 6 DAYS)			
TIME	OBJECTIVES/ACTIVITIES	TRAINING/LEARNING METHODS	RESOURCES/MATERIALS
Session Eleven: Day 6, AM			
15 minutes	Objective: Review day's scheduled activities.	Warmup Exercise	
195 minutes	Objectives: Provide participants opportunity to demonstrate competency (in the following skills areas) with clients under the supervision of trainers: <ul style="list-style-type: none"> • Providing counseling (including method-specific counseling) • Performing client assessments, including reproductive history, focused physical examination and laboratory tests (if indicated and available) • Inserting and removing IUDs, applying IP practices throughout • Providing postinsertion counseling and instructions on possible side effects and other problems 	Clinical Practice/Assessment: Participants perform the following guided clinical activities: <ul style="list-style-type: none"> • Counseling clients • Client assessment • IUD insertion with clients • IUD removal with clients (if available) • Follow-up care • Management of side effects and other problems Trainers continue assessing the performance and complete a Checklist for IUD Counseling and Clinical Skills for each participant.	Handbook: Checklist for IUD Counseling and Clinical Skills
Session Twelve: Day 6, PM			
15 minutes	Objective: Review selected cases from morning session.	Clinical Conference	
90 minutes	Objective: Assess on pelvic model inserting and removing IUD	Classroom Assessment: Divide in groups of 2-3 and on ZOE Pelvic Model evaluate pelvic exam and IUD insertion—placing the cervical tenaculum, sounding the uterus, inserting the IUD and removing the IUD.	Handbook: Checklist for IUD Clinical Skills Other: 1 ZOE pelvic model per 2-3 participants and 1 handheld uterine model per participant; participants should use IUDs from previous sessions
45 minutes	Objective: Provide information on and opportunity to practice skills related to management of lost strings.	Demonstration: Demonstrate and practice management of lost strings using ZOE and handheld models in small groups. Review steps to take if strings are missing.	Other: 1 ZOE pelvic model per 2B3 participants and 1 handheld uterine model per participant; participants should use IUDs from Session Two; extra IUDs in sterile packages for demonstration and practice
15 minutes	Objective: Identify strengths and weaknesses of the training course.	Evaluation: Each participant completes a course evaluation questionnaire.	Handbook: Course Evaluation
15 minutes	Closing	Graduation: Award certificates to graduates.	

PRECOURSE QUESTIONNAIRE

USING THE INDIVIDUAL AND GROUP ASSESSMENT MATRIX

The **precourse questionnaire** is not intended to be a test but rather an assessment of what the participants, individually and as a group, know about the course topic. Participants, however, are often unaware of this and may become anxious and uncomfortable at the thought of being “tested” in front of their colleagues on the first day of a course. The clinical trainer should be sensitive to this attitude and administer the questionnaire in a neutral and non-threatening way as the following guide illustrates:

- Participants draw numbers to assure anonymity (e.g., from 1 to 12 if there are 12 participants in the course).
- Participants complete the precourse questionnaire.
- The clinical trainer gives the answers to each question.
- The clinical trainer passes around the individual and group assessment matrix for each participant to complete according to her/his number.
- The clinical trainer posts the completed matrix.
- The clinical trainer and participants discuss the results of the questionnaire as charted on the matrix and jointly decide how to allocate course time.

PRECOURSE QUESTIONNAIRE ANSWER KEY

OVERVIEW

- | | | |
|--|-------------|--|
| 1. A good candidate for using an IUD is a woman who wants at least several years of contraception. | TRUE | Participant Objective 1
(Chapter 1) |
| 2. The risk of pelvic inflammatory disease in IUD users is related to sexually transmitted infections, not the IUD itself. | TRUE | Participant Objective 2
(Chapter 1) |
| 3. Women who have had an ectopic pregnancy in the past can use the IUD. | TRUE | Participant Objective 3
(Chapter 1) |

COUNSELING

- | | | |
|--|--------------|--|
| 4. The service provider is the person best qualified to choose a contraceptive method for a woman in good health. | FALSE | Participant Objective 4
(Chapter 2) |
| 5. Women who are not in a mutually faithful relationship (i.e., either partner has more than one sexual partner) are at increased risk for STIs and should be urged use condoms, in addition to the IUD, for protection. | TRUE | Participant Objective 4
(Chapter 2) |
| 6. Counseling about possible side effects and how to manage them increases continued contraceptive use. | TRUE | Participant Objective 4
(Chapter 2) |
| 7. The provider should avoid discussing “rumors” the woman may have heard about the method. | FALSE | Participant Objective 4
(Chapter 2) |
| 8. Clients should be counseled that after IUD insertion, heavy vaginal discharge often occurs, which requires frequent douching. | FALSE | Participant Objective 4
(Chapter 2) |

INFECTION PREVENTION

- | | | |
|---|--------------|--|
| 9. Surgical (metal) instruments that have been decontaminated and thoroughly cleaned can be sterilized by boiling them in water for 20 minutes. | FALSE | Participant Objective 5
(Chapter 3) |
| 10. High-level disinfection of gloves can be done by steaming them for 20 minutes. | TRUE | Participant Objective 5
(Chapter 3) |
| 11. Tarnished (discolored) IUDs still inside the undamaged, sealed package should be discarded because they are no longer sterile. | FALSE | Participant Objective 5
(Chapter 3) |
| 12. To minimize the risk of staff contracting hepatitis B or HIV/AIDS during the cleaning process, instruments and gloves first should be soaked for 20 minutes in 8% formaldehyde solution. | FALSE | Participant Objective 5
(Chapter 3) |

CLIENT ASSESSMENT

- | | | |
|--|--------------|-------------------------------------|
| 13. The physical examination of a potential IUD client must include breast, abdominal, and pelvic (speculum and bimanual) examinations. | FALSE | Participant Objective 6 (Chapter 4) |
| 14. If a woman is found to have a retroverted (posterior) uterus, she cannot have an IUD inserted. | FALSE | Participant Objective 6 (Chapter 4) |
| 15. If a client has current purulent cervicitis, the IUD should not be inserted at this time. | TRUE | Participant Objective 6 (Chapter 4) |

IUD INSERTION AND REMOVAL

- | | | |
|---|--------------|--------------------------------------|
| 16. To correctly insert the IUD, you must wear high-level disinfected or sterile gloves. | FALSE | Participant Objective 7 (Chapter 5) |
| 17. IUDs can be inserted at any time during the menstrual cycle provided that the client is not pregnant. | TRUE | Participant Objective 8 (Chapter 5) |
| 18. Following insertion of the IUD, the woman should be advised to return to the clinic after her next period (3 to 6 weeks). | TRUE | Participant Objective 9 (Chapter 5) |
| 19. A woman should not have her IUD removed unless she is willing to start another method immediately. | FALSE | Participant Objective 10 (Chapter 5) |
| 20. The Copper T 380A IUD should be removed/replaced in 12 years. | TRUE | Participant Objective 10 (Chapter 5) |
| 21. Prophylactic antibiotics should be given for routine IUD removal. | FALSE | Participant Objective 11 (Chapter 5) |

FOLLOW-UP CARE/MANAGEMENT OF POTENTIAL PROBLEMS

- | | | |
|---|--------------|--------------------------------------|
| 22. If a woman becomes pregnant with an IUD in place, she is more likely to have increased vaginal discharge. | FALSE | Participant Objective 12 (Chapter 6) |
| 23. When a woman is undergoing evaluation/treatment for a medical condition, the IUD usually does not need to be removed. | TRUE | Participant Objective 12 (Chapter 6) |

HOW PEOPLE LEARN²

SESSION OBJECTIVE

After completing this session, the participant will be able to identify how adults learn.

ENABLING OBJECTIVES

After completing this session, the participant will be able to:

- Compare formal (school) and practical (hands-on) methods of learning
- List the three stages of learning clinical skills
- Identify the key principles of learning

Competency will be determined by participation in this session, completion of the session activity sheets, and application of this information in a clinical setting.

STOP: CLINICAL TRAINER COMPLETE ACTIVITY 1

COMPARISON OF FORMAL (SCHOOL) AND PRACTICAL (HANDS-ON) METHODS OF LEARNING

- Characteristics of formal (school) teaching:
 - Structured
 - Instructor acts as though s/he is “better” than the students (top down)
 - Information usually is theoretical
 - Little or no interaction or student involvement
 - Few questions by the students
- Characteristics of practical training (e.g., the way a wood carver would teach his children about carving):
 - Informal
 - Learning is fun (low stress)
 - Learn by doing (hands-on)
 - Participatory (trainer and student are partners)
 - Interactive (questions going both ways)

² Adapted from: Sullivan R et al. 1995. *Clinical Training Skills for Reproductive Health Professionals*. JHPIEGO: Baltimore, MD.

- The practical method is more like **coaching** as opposed to school teaching. An example of where coaching is an appropriate training method is learning a skill such as IUD or Norplant implants insertion or removal.

How People Learn

- Training must be **relevant**. Learning experiences should relate directly to the job responsibilities of the participants.
- People often bring a **high level of motivation** and interest to training:
 - Desire to improve job performance
 - Desire to learn
 - Desire to improve their life
- People **need involvement** during training. This can be accomplished by:
 - Allowing participants to provide input regarding schedules, activities and other events
 - Using questioning and feedback
 - Using brainstorming and discussions
 - Providing hands-on work
 - Conducting group and individual projects
 - Setting up classroom activities or games
- People desire **variety**. Ways to provide this include:
 - Varying the schedule
 - Using a variety of audiovisual aids:
 - Writing boards
 - Flipcharts
 - Overhead transparencies
 - Slides
 - Videotapes
 - Anatomic models or real items (e.g., instruments)
 - Using a variety of teaching methods:
 - Illustrated lectures
 - Demonstrations
 - Small group activities
 - Group discussions

- Role plays and case studies
- Guest speakers
- People need **positive feedback**. Positive feedback is letting participants know how they are doing, and providing this information in a positive manner. The clinical trainer provides positive feedback when s/he uses one or more of the following:
 - Verbal praise either in front of other participants or individually.
 - Recognizing appropriate responses during questioning:
 - That’s correct!
 - Good answer!
 - That was an excellent response!
 - Acknowledging appropriate skills while coaching in a clinical setting:
 - Very good work!
 - I would like everyone to notice the incision that was just made. Ilka did an excellent job. All incisions should look like this one.
 - Letting the participants know how they are progressing toward achieving the learning objectives.
- The clinical trainer must recognize that many participants fear failure and embarrassment in front of their colleagues. Participants often have **concerns** about their ability to:
 - Fit in with the other participants
 - Get along with the trainer
 - Understand the content
 - Perform the skills being taught

The clinical trainer must be aware of these concerns and begin the course with an opening exercise that allows all participants to get to know each other in a safe and positive climate.

- People prefer to be treated as individuals who have **unique and particular backgrounds, experiences and learning needs**. The clinical trainer can ensure that participants feel like individuals by using one or more of the following methods:
 - Using participant names as often as possible
 - Involving all participants as often as possible
 - Treating participants with respect
 - Allowing participants to share information with others during classroom and clinical instruction

- Participants need to maintain **high self-esteem** to deal with the demands of clinical training. Respect on the part of the clinical trainer, which includes avoiding negative feedback, is essential to maintaining participant confidence while learning.
- The clinical trainer must maintain participants' **high expectations** by:
 - Conducting a training course which adds, rather than subtracts, from the participant's self-esteem and sense of competence
 - Setting high expectations for her/himself and her/his fellow trainers
 - Allowing participants to get to know and respect the trainer
 - Understanding and recognizing the participants' career accomplishments
- All participants have **personal needs** during training. Timely breaks from instruction, the best possible ventilation, proper lighting and an environment as free from distraction as possible reduce tension and create a positive atmosphere.

STOP: CLINICAL TRAINER COMPLETE ACTIVITY 2

STAGES OF LEARNING CLINICAL SKILLS

- **Skill acquisition** represents the initial phase in learning a new clinical skill or activity. One or more practice sessions are needed for learning how to perform the required steps and the sequence (if necessary) in which they should be performed. Assistance and coaching are necessary to achieve correct performance of the skill or activity.
- **Skill competency** represents an intermediate phase in learning a new clinical skill or activity. The participant can perform the required steps in the proper sequence (if necessary) but may not progress from step to step efficiently.
- **Skill proficiency** represents the final phase in learning a new clinical skill or activity. The participant efficiently and precisely performs the steps in the proper sequence (if necessary).

Principles of Learning (Keys to Success)

- The most productive way of learning is by **doing**. **Repetition** is necessary for **proficiency**.
- The more **realistic** the content, the more productive the learning.

- Learning is:
 - Most productive when the participant is **ready to learn** (It is up to the clinical trainer to create a climate that motivates participants.)
 - Most productive when it **builds on** what the participant already has experienced or knows
 - Easier when the participant knows **what he/she is expected to learn**
 - More fun when a **variety** of training methods and teaching techniques are used

STOP: CLINICAL TRAINER COMPLETE ACTIVITY 3

SUMMARY

1. What are the differences between the formal (school) and practical (hands-on) methods of learning? **Answers:**
 - Formal: structured, instructor acts as though s/he is “better” than the students (top down), information usually is theoretical, little or no interaction or involvement, few questions by the students
 - Practical: informal, fun, learn by doing, participatory, interactive

2. What should the clinical trainer do to encourage learning? **Answers:**
 - Relate the training to participant’s job
 - Build on the participant’s high level of motivation and interest
 - Involve participants in learning
 - Vary the learning experience
 - Provide positive feedback
 - Consider participant’s personal concerns
 - Consider participant’s individual background, experience and learning needs
 - Maintain participant’s self-esteem
 - Maintain participant’s high expectations
 - Consider participant’s personal needs

3. What are the three stages of learning clinical skills? **Answers:**
 - Skill acquisition
 - Skill competency
 - Skill proficiency

4. What are some of the principles of clinical instruction? **Answers:**

- Repetition is necessary for proficiency
- Content must be realistic
- A variety of teaching methods should be used
- Learners must be ready to learn
- Training should build on what the learner already knows
- Learners must be aware of the training objectives

ACTIVITY 1: LOADING THE TCU 380A IUD IN THE STERILE PACKAGE OR BUILDING A PAPER BOX

OBJECTIVES

The participants will be able to point out the importance of effective training and coaching.

Time: 20 minutes

Materials

- Sufficient number of IUDs in the sterile package or pieces of paper to build the box for each participant
- Handout describing “How to Load the Copper T 380A in the Sterile Package” or “How to Build a Paper Box”
- Flipchart paper and markers *or* overhead transparency *or* white board

INSTRUCTIONS TO THE TRAINER

- This activity requires two sessions. An **ineffective** clinical trainer teaches the first; an **effective** clinical trainer/coach teaches the second.
- Conduct this activity by following the steps below.
 1. Ask the participants to work individually and load an IUD or build a box following your instructions (demonstrate this first session working rapidly, and using *ineffective coaching and training* techniques).
 - Do not state any objectives. Just start demonstrating how to load the IUD or build the box.
 - Do not show a sample to the participants.
 - Do not provide a handout explaining the steps.
 - Display a negative attitude and do not provide positive feedback.
 - Do not maintain eye contact.
 - Do not ask questions or interact with the participants.
 - Do not offer any help or assistance.

Note: For the IUD course, loading the Copper T 380A in the sterile package is very appropriate and works well. For other courses the box building activity can be used. For either activity, load an IUD and build a box in advance to show to the participants at the start of the second session.)

2. After the demonstration, conduct a brainstorming session. Ask for a list of all the poor training and coaching techniques the participants observed. List these on one side of a flipchart, writing board, or overhead transparency.
3. Ask the participants for suggestions of how the demonstration could have been improved. List these suggestions on the flipchart or transparency next to the first list, and compare the two lists.
4. Ask the participants to work individually again and load an IUD or build a box using the instructions of an *effective coach and trainer*.
 - State the objective while showing the participants the loaded IUD in the package or the box they will be building.
 - Distribute a handout describing the steps of the activity and materials needed for the activity (see pages 7–9).
 - Demonstrate the entire activity once and then show each step individually.
 - Repeat individual steps for participants to follow.
 - Ask if there are any questions or if anyone needs assistance.
 - Ask participants to practice loading the IUD or to build additional boxes until they feel comfortable in mastery of the skill.
 - Check their progress, giving immediate feedback and correcting mistakes.

SUMMARIZE THE MAIN POINTS

Compare the *ineffective* with the *effective* training and coaching techniques. Reiterate the importance of each of the steps in Number 4 above. Also, relate this exercise with the importance of positive feedback when they return to their workplaces and start coaching people on new practices.

ACTIVITY 1 HANDOUT: HOW TO LOAD THE COPPER T 380A IN THE STERILE PACKAGE³

Do **not** open the IUD's sterile package or load it (as instructed below) until the final decision to insert an IUD has been made (i.e., until after the pelvic examination, including both bimanual and speculum exams, has been performed). In addition, do not bend the "arms" of the "T" into the insertion tube more than 5 minutes before the IUD is to be introduced into the uterus.

While performing the following steps, do not allow any part of the IUD or the IUD insertion assembly to touch any non-sterile surfaces (e.g., your hands, the table) that may contaminate it:

STEP 1: Adjust the contents of the package through the clear plastic cover:

- Ensure that the vertical stem of the T is fully inside the insertion tube (Figure 1, arrow).
- Ensure that the other end of the insertion tube (farthest from the IUD) is close to the sealed end of the package.

Figure 1. Vertical Stem of T Fully inside Insertion Tube

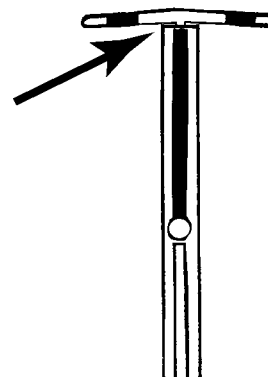

STEP 2: Partially open the package:

- Place the package on a clean, hard, flat surface with the clear plastic side up.
- Pull up on the clear plastic cover from the end that is farthest from the IUD (marked OPEN).
- Keep pulling the plastic cover until the package is open approximately half way to the blue depth-gauge.

STEP 3: Place the white plunger rod in the clear insertion tube:

- Pick up the package, holding the open end up toward the ceiling so that the contents do not fall out.
- Starting at the open end of the package, fold the clear plastic cover and white backing "flaps" away from each other (as shown in Figure 2a).
- Using your free hand, grasp the white plunger rod (behind the measurement insert) by the circular thumb grip and remove it from the package.

³ Adapted from: The Population Council and Program for Appropriate Technology in Health (PATH). 1989. *The Copper T 380A IUD: A Manual for Clinicians*, 2nd ed. PATH: Seattle, Washington.

Do **not** touch the tip of the white plunger rod or brush it against another surface, as this will cause it to lose its sterility.

- Place the plunger rod inside the insertion tube (Figure 2a) and gently push until the tip of the rod almost touches the bottom of the T (Figure 2b, arrow).

Figure 2a. Placing White Plunger Rod inside Insertion Tube

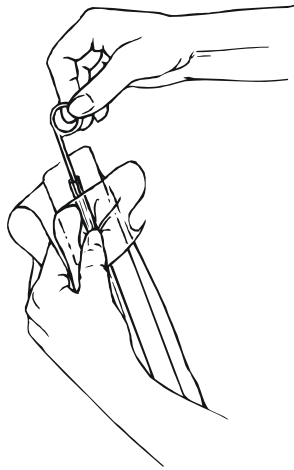
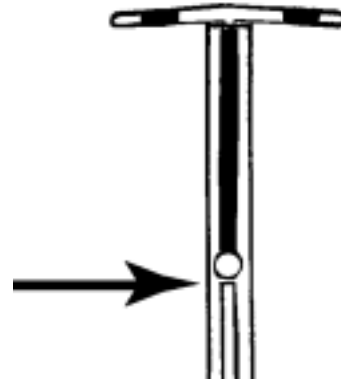

Figure 2b. Plunger Rod almost Touching Bottom of T



STEP 4: Bend the “arms” of the “T” downward:

Do **not** bend the arms of the T into the insertion tube more than 5 minutes before it is introduced into the uterus.

- Release the white backing flap so that it is flat again, and place the package back on the clean, hard, flat surface with the clear plastic side up.
- Through the clear plastic cover, place your thumb and index finger over the tips of the horizontal arms of the T to stabilize the IUD (Figure 3, open arrow).

Figure 3. Positioning IUD and Bending Arms of T

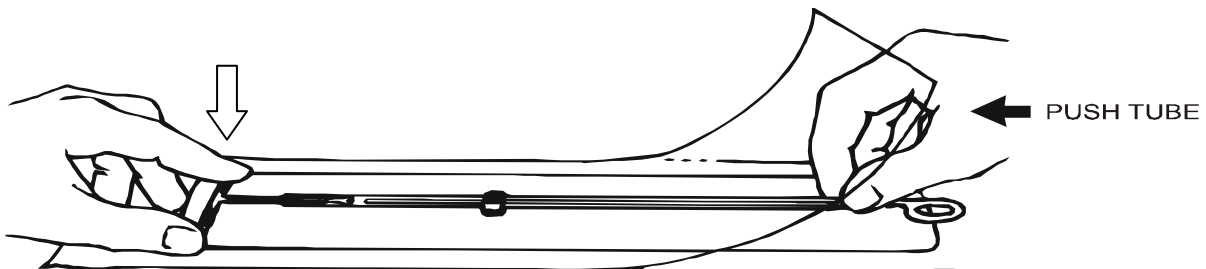

- At the open end of the package, use your free hand to push the measurement insert so that it slides underneath the IUD and stops at the sealed end of the package.
- Still holding the tips of the arms of the T, use your free hand to grasp the insertion tube and gently push it against the T (Figure 3, solid arrow). This pressure will cause the arms to begin bending downward, toward the stem of the T (as shown on the measurement insert).
- Finish bending the arms of the T by bringing your thumb and index finger together, and continuing to push against the T with the insertion tube.

STEP 5: Pull the insertion tube away from the folded arms of the T:

When the arms of the T are folded down enough to touch the sides of the insertion tube, pull the insertion tube out from between the arms.

STEP 6: Push the folded arms of the T into the insertion tube:

- Gently push and rotate the insertion tube back over the **tips** of the folded arms of the T, so that both tips are caught inside the insertion tube (Figure 4, Upper image). (As you maneuver the tips of the arms into the opening of the tube, it may help to slightly elevate the other end of the tube.)
- Push the folded arms of the IUD into the insertion tube only as far as necessary to keep them fixed in the tube (Figure 4, Lower image). Do not try to push the copper bands on the arms into the insertion tube, as they will not fit.

Figure 4. Inserting Folded IUD Arms into Insertion Tube

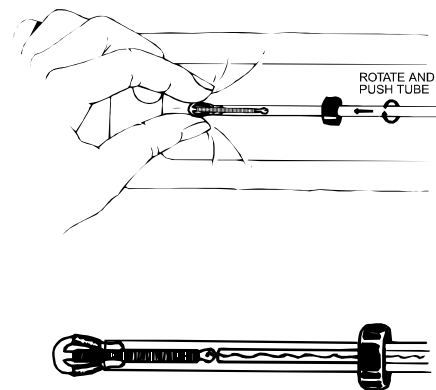

STEP 7: Set the blue depth-gauge to the appropriate measurement:

With the loaded IUD still in the partially unopened package, set the blue depth-gauge to the corresponding measurement obtained from sounding the uterus:

- Move the depth-gauge so that its inside edge (the edge closest to the IUD) is aligned with the appropriate centimeter mark on the measurement insert (e.g., 6 cm, 7.5 cm, 8 cm).
- Press down on the depth-gauge with the thumb and index finger of one hand to keep it in place, while sliding the insertion tube with your other hand until the tip of the IUD (the top of the folded T) aligns with

Figure 5. Using Blue Depth-Gauge to Set Depth of Uterus on Insertion Tube

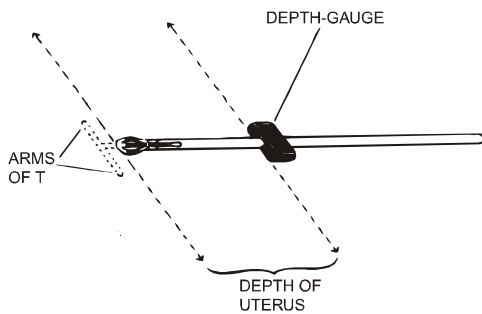

the tip in the diagram on the measurement insert. This is the “0” centimeter mark.

- Ensure that the distance between tip of the IUD and the inside edge of the depth-gauge is equal to the depth of the uterus as determined by uterine sounding (Figure 5).

STEP 8: Align the depth-gauge and the folded arms of the T so that they are both in a “horizontal” position (i.e., flat against the measurement insert).

STEP 9: Remove the loaded IUD from the package:

- Finish peeling back the clear plastic cover from the white backing in one brisk, continuous movement with one hand, while holding the insertion assembly down against the white backing on the table (at the open end of the package) with the other hand.
- Lift the loaded IUD from the packaging, keeping it level so that the T and white plunger rod do not fall out (Figure 6). **Be careful not to push the white rod toward the T, as this will release the IUD from the insertion tube.**

Do **not** let the IUD or IUD insertion assembly touch any non-sterile surfaces that may contaminate it.

Figure 6. IUD Fully Loaded in Insertion Tube

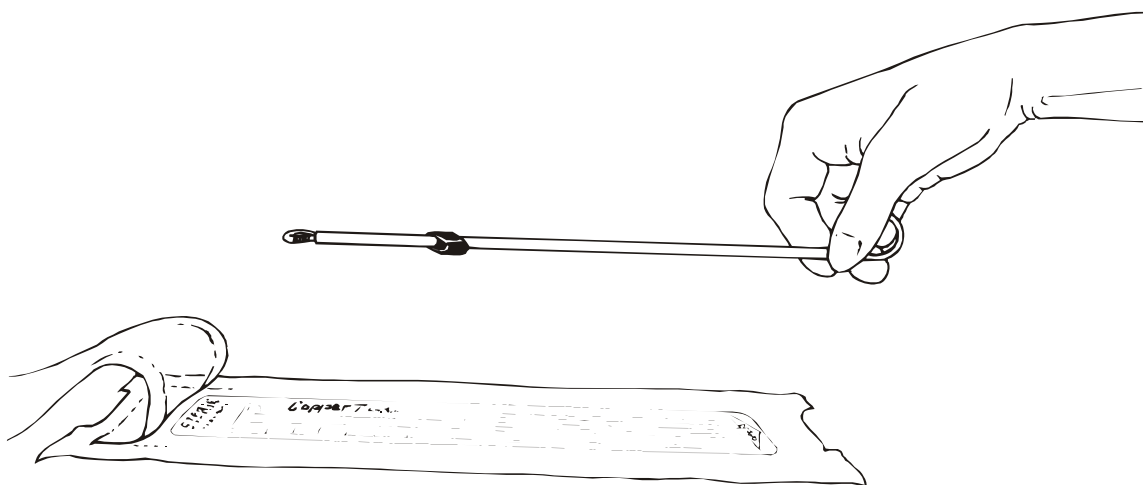

You are now ready to insert the IUD, as instructed in Chapter 5 (page 5-9) of the IUD reference manual.

INSTRUCTIONS: HOW TO BUILD A PAPER BOX

STEPS IN THE PROCEDURE

KEY POINTS

Figure 1

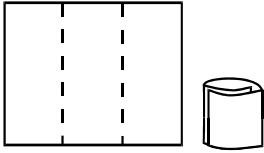

1. Make two crosswise creases.

Divide the paper into **three equal** parts. To do this, roll the paper into a cylinder, matching the ends.

Figure 2

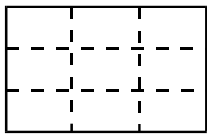

2. Make two lengthwise creases.

Divide the paper into **three equal parts**. To do this, roll the paper into a cylinder, matching the ends.

Figure 3

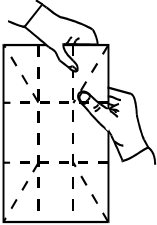

3. Make diagonal creases at the corners.

The diagonal crease starts at the point where the lengthwise and crosswise creases (corners) intersect. **One** corner at a time, match the lengthwise and crosswise creases. Corners should fold **away**.

Figure 4

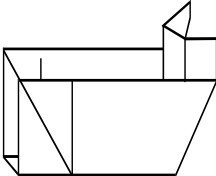

4. Fold the ends of the box.

Fold around the **end** of the box, not the sides. Overlay corners evenly. Corners should be square.

Figure 5

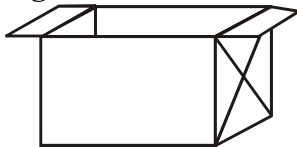

5. Fold the flaps down.

Bend the flaps out in line with top of the box.

ACTIVITY 2: THE NUMBER GAME

(Estimated time: 15 minutes)

OBJECTIVES

The participants will be able to demonstrate the importance of practice and repetition in learning a skill.

Time: 15 minutes

Materials

- Handouts of the page full of numbers (see pages 11–13), three copies for each participant (refer participants to “The Number Game” pages in their Participant’s Handbooks)

INSTRUCTIONS TO THE TRAINER

- Have the participants place the sheets of numbers **face down** in front of them so they cannot see the numbers.
- Explain that this is a simple hand-eye coordination exercise in which they are to work as fast as they possible can within a given time period.

PROCEDURE

1. Have the participants turn over the top sheet, mark it with a **#1** at the top, and with pen or pencil draw a line from #1 to #2 to #3, etc. until they connect all the numbers or are told to stop, whichever comes first.
2. **Allow 60 seconds for the exercise.** Then ask the participants to stop, circle the highest number reached, and set this page aside.
3. Repeat this procedure (turn the next page over and have them mark it with a **#2** at the top, then begin to connect the numbers, starting with #1) for another **60 seconds**.
4. Repeat this procedure (turn the next page over and have them mark it with a **#3** at the top, then begin to connect the numbers, starting with #1) for another **60 seconds**.
5. When finished, have the participants turn over all three pages and see how far they progressed with each subsequent page.
6. Make a graph of the participants’ progress on a flipchart.

DISCUSSION QUESTIONS

1. How did you feel during the exercise?
2. “Practice makes perfect” is a saying that applies here. If it is really true, all should have shown a significant increase in the number attained with each attempt. Is it true for all participants? If not, why not?

SUMMARIZE THE MAIN POINTS

Something that looks simple and fun is one way to show us how important it is to practice, practice, practice until we can do the steps well and fast.

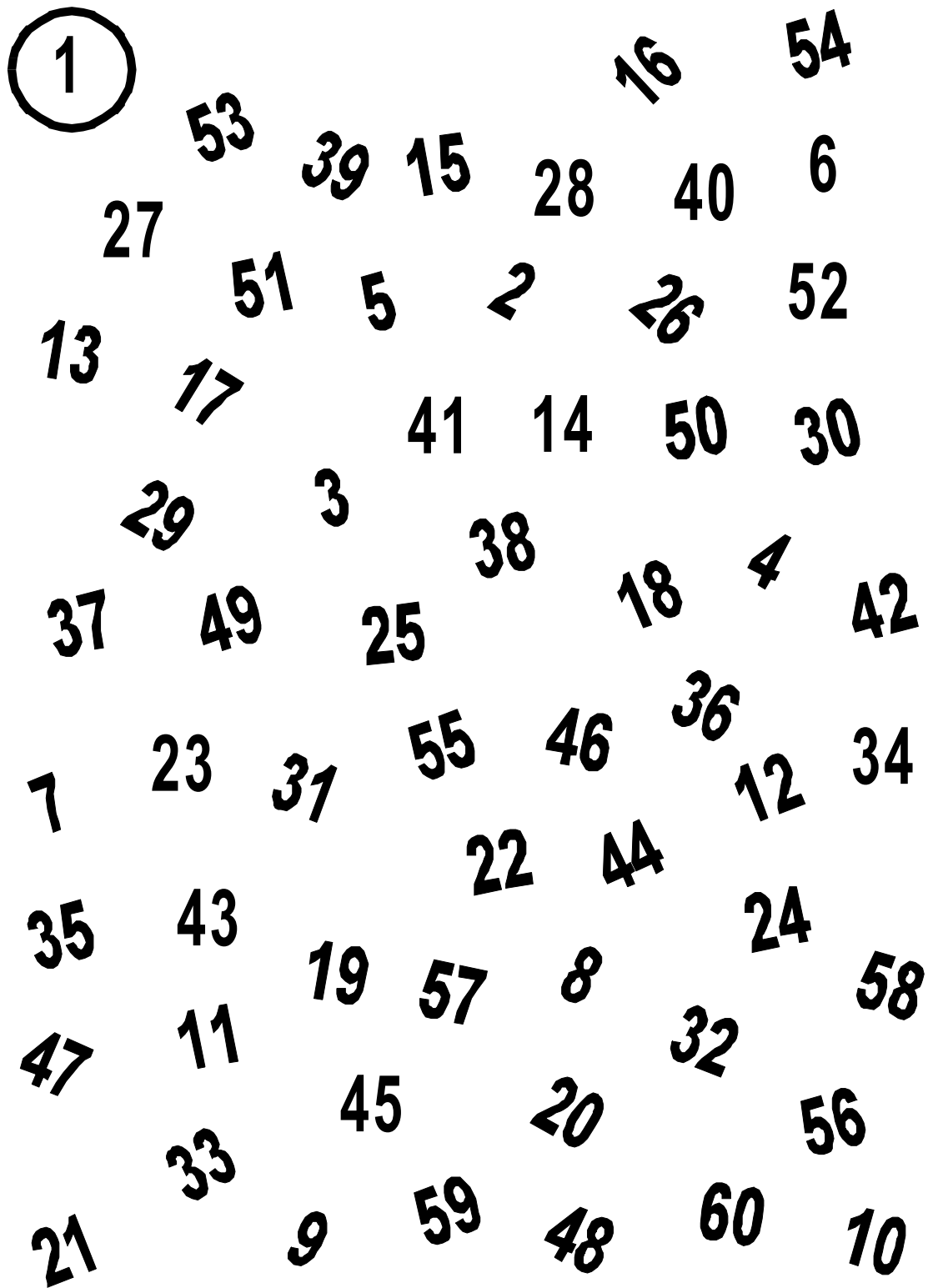

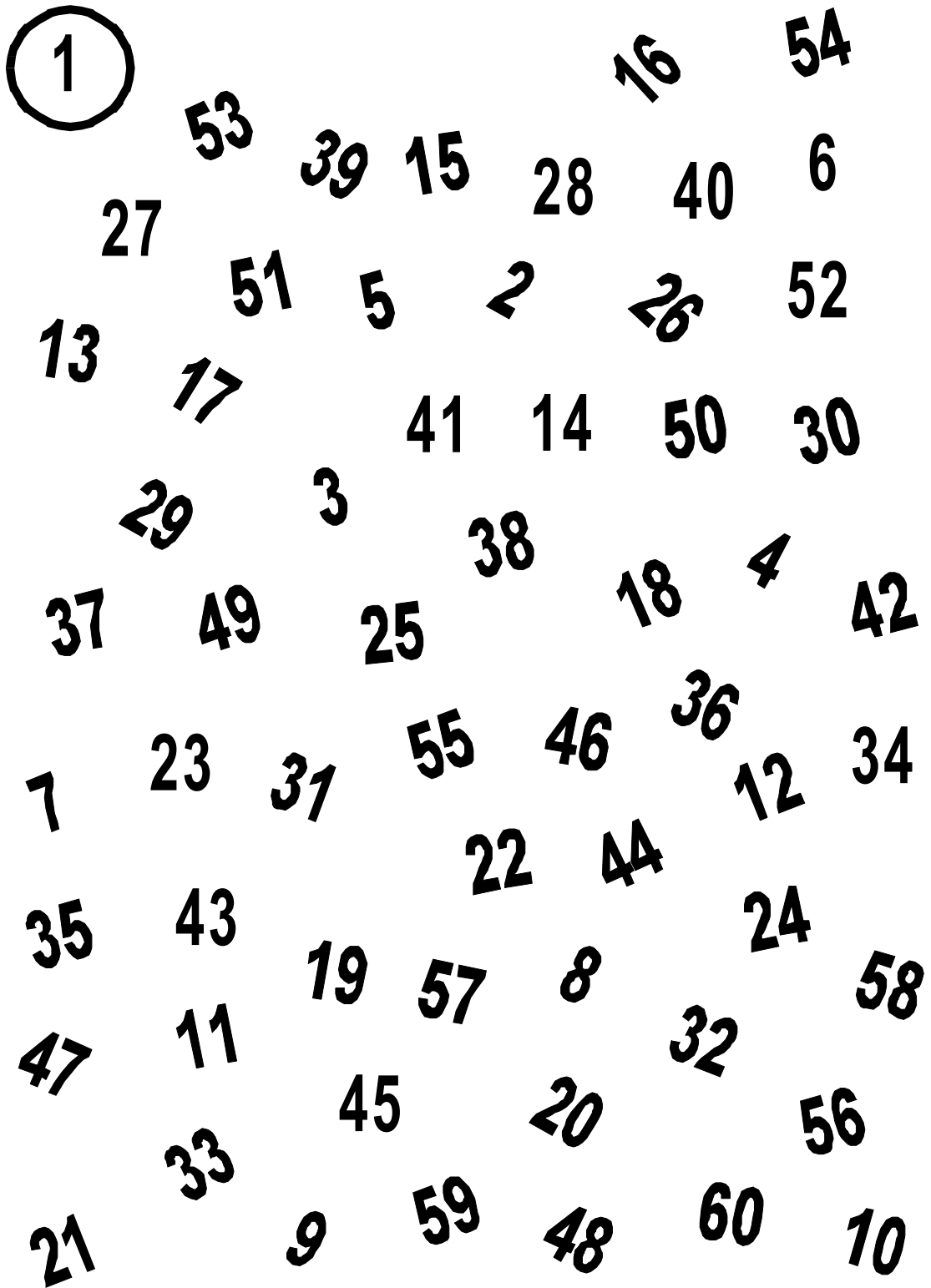

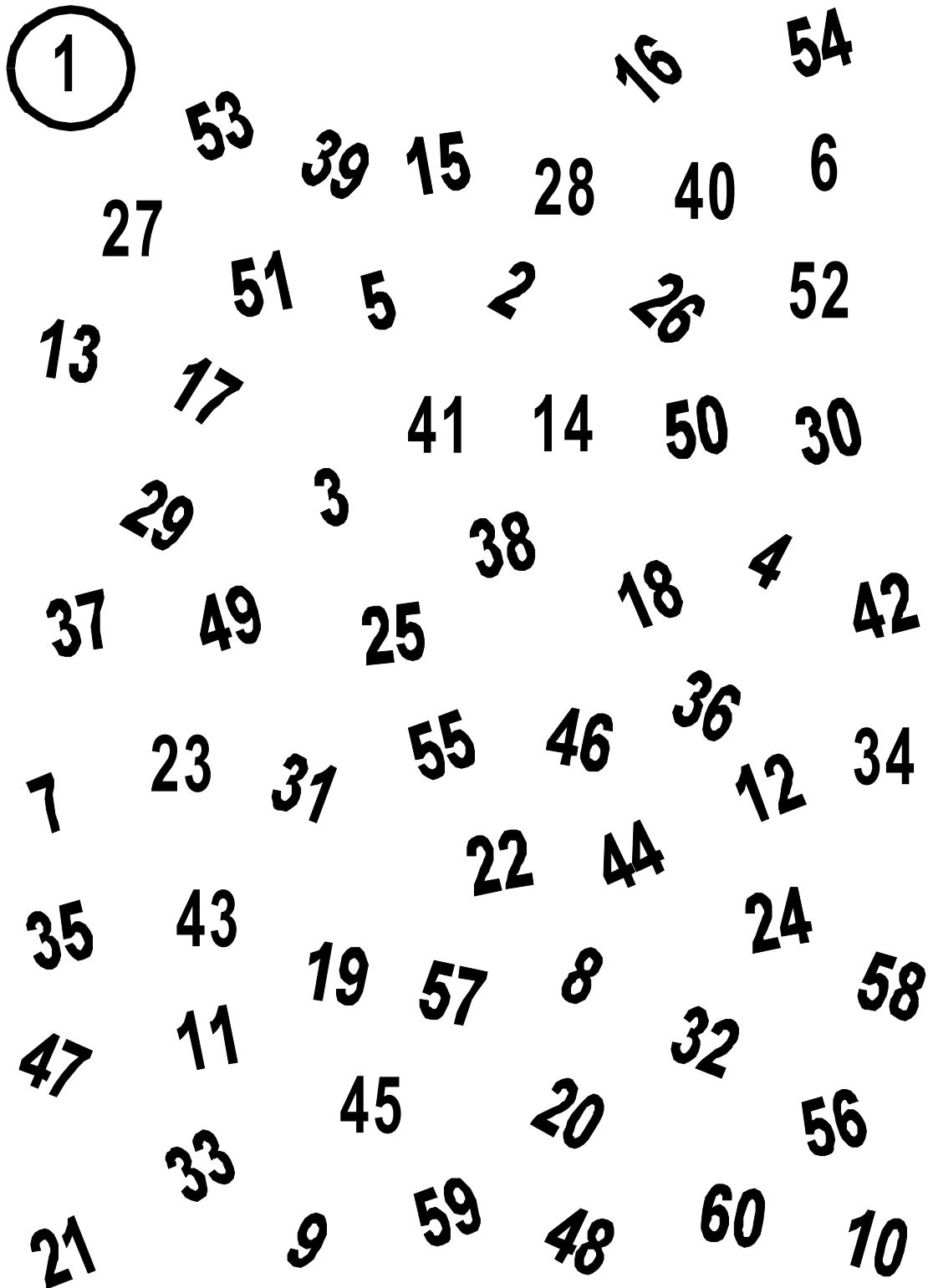

ACTIVITY 3: THE NINE DOTS PUZZLE

(Estimated time: 15 minutes)

OBJECTIVE

The participants will be able to use their imaginations for creative ways to solve problems.

Time: 15 minutes

Materials

- Flipchart or white board, and blank papers with pencils or pens for participants

INSTRUCTIONS TO THE TRAINER

Draw nine dots (as illustrated below) on the flipchart or white board for all participants to see.

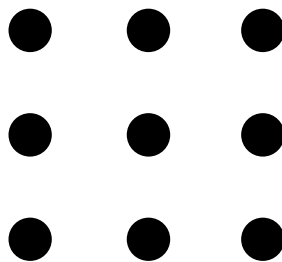

PROCEDURE

1. Have the participants copy this nine-dot configuration exactly onto their blank sheet of paper.
2. **Give these instructions:** “Without taking pen or pencil off your paper, connect all nine dots with four (4) straight lines.”
3. Give them some time to work on the puzzle.
4. If some of the participants have seen this puzzle, ask them to do it with only three (3) straight lines.
5. Ask one or more volunteers to show how to solve the puzzle on the flipchart.

DISCUSSION QUESTIONS

1. Ask the participants to identify the problems they had when working the puzzle.
2. We often find ourselves constrained or boxed in on many projects. How can we counteract such situations?

SUMMARIZE THE MAIN POINTS

- Something that looks difficult to resolve may not be so difficult as first imagined.
- Some people may see the resolution very quickly, and be frustrated by those who cannot.
- Thinking about problems in a new way is a technique that can be learned and taught. Sometimes you have to look “outside of the box.”
- Do not assume you already know all the parts or pieces to a problem. Many times, you have to actually go and look at a problem/situation to come up with a reasonable and helpful solution.

WARMUP/OTHER EXERCISE: THE NINE DOTS PUZZLE ANSWER KEY

As a reminder, the most frequently used solution for connecting all nine dots with four (4) straight lines is shown here:

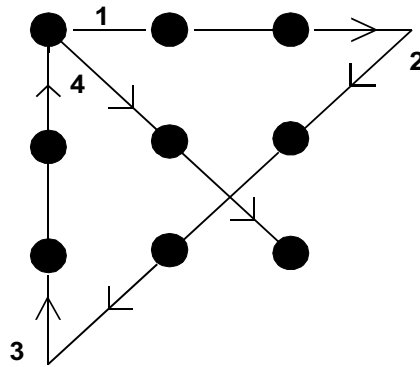

To connect all nine dots with three (3) straight lines, try this solution:

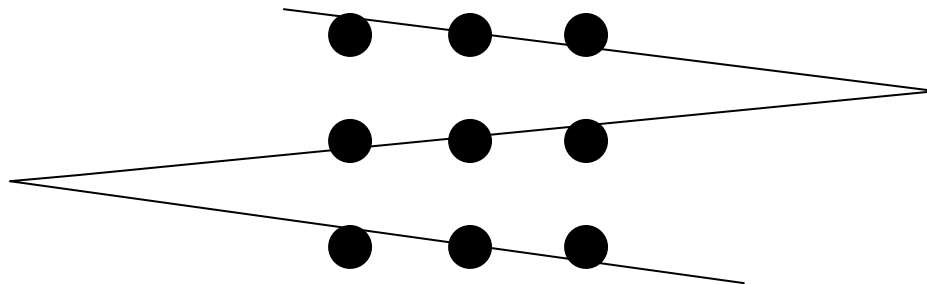

PRECOURSE ASSESSMENT CHECKLIST FOR IUD COUNSELING AND CLINICAL SKILLS

USING THE CHECKLIST

This skills assessment activity is intended to assist both the **clinical trainer** and **participant** as they begin their work together in the course. The results will identify those counseling and clinical skills (e.g., pelvic examination) that are performed satisfactorily and those that may need to be learned or require additional practice during the course.

Each participant will receive a copy of her/his completed assessment at the beginning of the course. S/he should use the results of the assessment to guide her/his learning activities during guided clinical activity sessions.

In using the checklist, it is important that the scoring be done carefully and correctly. If the step or task is performed satisfactorily, the clinical trainer should mark a “✓” in the “**Satisfactory**” column. If any step or task is performed incorrectly or out of sequence, the clinical trainer should mark an “X” in the “**Unsatisfactory**” column. For any “**Unsatisfactory**” rating, the clinical trainer should note specific deficiencies to assist the participant in learning or correcting the performance of this step or task during the classroom and clinical practice sessions.

Satisfactory:	Performs the step or task according to the standard procedure or guidelines.
Unsatisfactory:	Unable to perform the step or task according to the standard procedure or guidelines

PRECOURSE ASSESSMENT CHECKLIST FOR IUD COUNSELING AND CLINICAL SKILLS

Instructions: Place a “✓” in the “Satisfactory” column if the step or task is performed correctly, or an “X” in the “Unsatisfactory” column if it is performed incorrectly or out of sequence.

Participant _____ Course Dates _____

STEP/TASK	SATISFACTORY	UNSATISFACTORY/ COMMENT
COUNSELING (General)		
Greet client respectfully and with kindness.		
Establish purpose of the visit and answer questions.		
Ask client about past experiences with family planning and reproductive goals.		
Ask whether she is interested in a particular method.		
Provide general information about family planning and different methods.		
COUNSELING (Method-Specific)—Optional		
Explain how the IUD works, its effectiveness, and other basic attributes.		
Describe common side effects and potential health problems associated with the IUD.		
Explain the IUD insertion procedure (using the hand-held uterine model) and what to expect.		
PELVIC EXAMINATION		
Wash hands thoroughly with soap and water; and dry them with clean, dry cloth or allow them to air-dry.		
Put new/clean examination or high-level disinfected (or sterile) surgical gloves on both hands.		
Inspect external genitalia and urethral opening.		
Speculum Examination		
Insert vaginal speculum.		
Check for vaginal/cervical discharge, and assess appearance of the cervix.		
Collect vaginal, cervical, or urethral specimens, if indicated and if testing is available.		
Bimanual Examination		
Determine size, shape, and position of uterus.		
Check for enlargement or tenderness of the adnexa, and cervical motion tenderness.		
Perform rectovaginal examination, if indicated.		
Place all instruments in 0.5% chlorine solution for 10 minutes for decontamination after use.		
Remove gloves and correctly dispose of examination gloves, or immerse surgical gloves (if reusing) in 0.5% chlorine solution for 10 minutes for decontamination.		

WHO HAS AIDS?

Exercise used to introduce infection prevention session

OBJECTIVES	INSTRUCTIONS	RESOURCES/ MATERIALS
<p>The purpose of this activity is to:</p> <ul style="list-style-type: none"> ■ Make participants aware that anyone may have HBV or HIV/AIDS ■ Help participants see that HBV or HIV/AIDS is a problem everywhere, not just in other countries 	<ul style="list-style-type: none"> ■ Distribute one envelope to each person. ■ Ask participants to look under the flap of their envelope and remember the letter written there but not to reveal it to anyone. ■ Have participants exchange envelopes and write their first letter next to the one written on the new envelope. ■ Have them exchange envelopes and again write their first letter next to the one written on the new envelope. ■ Tell participants that those holding an envelope with the letter “A” written on it have been exposed to AIDS; those with envelopes having “B” or “C” written on them are still uninfected. ■ Ask how many people have envelopes with “A”s, how many with “B”s, and how many with “C”s. Tell the group how many of each letter you started with. ■ Ask participants: How do you feel about continuing the envelope exchange? Why don’t you want to continue? How can you protect yourself in health care situations? 	<p>Envelopes equal to number of participants with letters A, B, C marked under flap (approximately 10% with A, B, C)</p> <p>Flipchart</p> <p>Paper, markers</p>

EXERCISE 1 KEY: WHO MEDICAL ELIGIBILITY CATEGORIES

1. Which two eligibility categories mean you may provide the method? **Categories 1 & 2**
2. Which two eligibility categories mean you generally should not use or can't use the method? **Categories 3 & 4**
3. Which WHO category means use of the method is generally **not** recommended, and you should only use it if no other method is available or acceptable? **Category 3**
4. A woman has diabetes. What is the WHO category of this condition for IUD use? **Category 1**
5. A woman comes to you and would like an IUD. She is HIV-infected, her CD4 count is 400, and she is clinically well. What is the WHO category of this condition? **Category 2**
Can you give this woman the IUD? Why or why not? **Yes, because the benefits generally outweigh the risks.**
6. The same woman comes to see you several years later. Now she has AIDS, her CD4 count is 150, and she is not on antiretroviral therapy. What is the WHO category for this woman for **continuing** the IUD? **Category 2**
What would the WHO eligibility category be for the same situation for **insertion**, not continuation? **Category 3**
7. If a woman has AIDS but is on antiretroviral therapy and receiving clinical care, what is the WHO category for IUD **insertion**? **Category 2**
For **continuation**? **Category 2**
8. A woman who wants the IUD has a reddened vagina and complains of some irritation. On pelvic examination, there is no purulent discharge, and STIs have been ruled out by lab tests. You treat her for bacterial vaginosis. Can you insert the IUD on this visit? Why or why not? **Yes, because bacterial vaginosis is not a contraindication for IUD insertion.**

9. List six of the WHO category 4 conditions for IUD insertion. **Any of these: pregnancy; current gonorrhea, chlamydia, PID, purulent cervicitis; distorted uterine cavity; unexplained vaginal bleeding; puerperal sepsis; post-septic abortion; cervical cancer awaiting treatment.**

10. A woman has herpes. What is the WHO category of this condition for IUD use? **Category 2**

11. A woman is nulliparous and would like the IUD for several years of protection. What is the WHO category? **Category 2**

What additional information/counseling would you give her about nulliparity and the IUD? **The risk of expulsion is slightly increased in nulliparous women; she should check for possible IUD expulsion carefully during the first few months.**

12. A woman had PID several months ago, but she and her partner have been treated. Upon reexamination, you find nothing unusual and she currently has no known risk factors for STIs. Can you give this woman the IUD? Why or why not? **Yes, history of PID is not a contraindication to IUD insertion, assuming there are no known risk factors for STIs.**

EXERCISE 2 KEY: COUNSELING IUD USERS

Here are some sample scenarios for use in counseling role plays. Participants should use their learning guides as well as any informational/educational brochures or leaflets during practice.

1. A woman comes in who is interested in using an IUD. Counsel her using the GATHER technique.
2. A woman comes in who wants long-term contraceptive protection. As you are counseling her using the GATHER technique, she tells you she is concerned that an IUD can become dislodged and travel into other parts of her body. Address her fears by showing her how the IUD works using a handheld model or picture.
3. A woman comes in who is interested in using an IUD. As you are counseling her using the GATHER technique, she tells you she is concerned about the IUD will affect existing menstrual bleeding problems (heavy, prolonged, painful). Address her fears.
4. A woman comes in seeking contraception. As you are counseling her using the GATHER technique, she tells you that she got gonorrhea from her husband last year and is worried about getting another infection from him. Counsel her as appropriate.

EXERCISE 3 KEY: INFECTION PREVENTION

1. Which is the most important of the standard precaution practices?
Handwashing
2. Which is the first step in instrument processing and what is its purpose?
Decontamination—to make instruments safer to handle for the person who processes them
3. What is the key difference between sterilization and high-level disinfection?
Sterilization destroys all endospores; high-level disinfection destroys only some.
4. When inserting an IUD, the client should put on a clean gown—true or false?
FALSE. There is no need for a clean gown if the woman's clothing is clean.
5. List the two antiseptics that may be used to cleanse the cervix and vagina prior to IUD insertion or removal.
Povidone iodine or chlorhexidine gluconate
6. Why is it appropriate to use new/clean examination gloves, rather than high-level disinfected (or sterile) surgical gloves, when inserting an IUD?
Because loading the IUD in the sterile package and using the no-touch technique are sufficient to prevent infection, making high-level disinfected (or sterile) gloves unnecessary
7. Define the **no-touch** technique.
A technique that reduces the risk of contaminating the uterus by ensuring that the uterine sound and loaded IUD:
 - **Do not touch the vaginal wall or speculum blades as they pass through vaginal canal, and**
 - **Pass through cervical canal only once**
8. A tarnished IUD inside its intact, sterile package is contaminated and should not be used—true or false?
FALSE. If a tarnished IUD is inside an intact, sterile package and the expiration date has not passed, it is safe to use.

EXERCISE 4 KEY: CLIENT ASSESSMENT

1. During the menstrual history, the woman complains of heavy menstrual bleeding and cramping. What would be your concern about the IUD for this woman?
It may worsen her menstrual bleeding problems.
2. When gathering her general medical history, you should ask every potential IUD user about which three medical conditions?
Complicated valvular heart disease, HIV/AIDS, cancer of the reproductive organs (awaiting treatment)
3. During the reproductive history, the woman complains of purulent discharge. What are three possible diagnoses?
Gonorrhea, chlamydia, PID
4. What are you checking for when palpating the abdomen during the physical examination?
Suprapubic or pelvic tenderness; swellings, bulges, masses, or other gross abnormalities
5. What are two reasons that the bimanual examination is so important?
To determine the shape and position of the uterus, which helps avoid uterine perforation during uterine sounding and IUD insertion and reveals uterine abnormalities (e.g., retroverted uterus); and to confirm the size and consistency of the uterus to help rule out pregnancy
6. During the visual inspection of the cervix using a speculum, list three things you are looking for.
Purulent discharge; ulcers, lesions, or sores; narrowness of cervical canal (stenosis)
7. In what situation would you perform a rectovaginal examination?
If you are unable to determine uterine position by bimanual exam (such as when it is retroverted)
8. A woman has purulent cervical discharge, what should you do?
If STI testing is available, rule out gonorrhea and chlamydia. These conditions must be ruled out before an IUD can be inserted. If STI testing is not available, consider presumptive treatment of the woman and her partner. Provide a back-up method for them to use while undergoing testing and/or treatment.

9. You are preparing to insert an IUD. When you insert the speculum, you notice purulent discharge from the cervix. What do you do?
The IUD should not be inserted until PID, gonorrhea, and chlamydia have been ruled out or successfully treated. Conduct further evaluation and provide treatment for woman and partner(s) (refer if needed). Provide back-up method to use during interim (encourage use of condoms). Instruct woman to return for reassessment and possible IUD insertion after she and partner complete treatment.

EXERCISE 5 KEY: IUD INSERTION AND REMOVAL

1. List five things you can do to prevent infection when inserting an IUD.
Any of the following are correct: wash hands; cleanse cervix and vagina with an antiseptic; use new/clean examination gloves; load the IUD in the sterile package; use no-touch technique when sounding the uterus and inserting the IUD; process instruments and other items according to recommended IP practices; properly dispose of waste materials

2. List the two antiseptics that are appropriate for cleansing the cervix or vagina.
Povidone iodine or chlorhexidine gluconate

3. You sound the uterus at 8 cm; to what distance do you set the depth-gauge before IUD insertion?
8 cm

4. You are explaining common side effects to a woman who just had an IUD inserted. What three points do you want to be sure to address about menstrual changes?
 - **Menstrual bleeding and cramping tend to increase the first few months after IUD insertion**
 - **Using ibuprofen or another NSAID prophylactically can help make this side effect more manageable**
 - **If bleeding lasts twice as long or is twice as heavy as usual, the woman should return to the clinic immediately.**

EXERCISE 6 KEY: QUIZ

1. When should a woman return for her first scheduled follow-up visit?
3–6 weeks after insertion
2. When else should she return to the clinic?
If she experiences warning signs (PAINS), if she has other problems or concerns, if she wants the IUD removed, or for any reason at all
3. List three questions to ask clients when they return the first time.
Any of the following are correct: How do you like the IUD? Have you had any problems? Are you experiencing side effects? Have you had any new sexual partners; if so, what are you doing to protect yourself from STIs? Can you feel your strings; have they changed in length?
4. The manual lists seven potential problems that may occur with IUD users. Which one is the most common cause of IUD removal?
Changes in the menstrual bleeding pattern
5. If a woman becomes pregnant with the IUD in place, there are two things that are very important to do as soon as possible. What are they?
Rule out ectopic pregnancy and remove the IUD.
6. A woman comes to you and has heavy bleeding and cramping with her periods. She is extremely unhappy. What can you do to help her?
Provide counsel and support; advise ibuprofen 200–400 mg every 4–6 hours a day before and during her period; arrange for follow-up in several weeks.
7. What are three possible signs of uterine perforation during uterine sounding or IUD insertion?
Sudden loss of resistance when sounding or inserting IUD; uterine depth greater than expected from sound; unexplained pain
8. A woman is concerned about uterine perforation and asks for details about incidence and usual side effects. What can you tell her?
It is rare (less than 1/1000 insertions), and complications related to perforation are very rare.

9. What are some of the signs/symptoms that can indicate expulsion, other than missing strings?

Irregular bleeding, pain with intercourse, unusual vaginal discharge, postcoital bleeding, lengthening of strings

10. A woman with an IUD who has a partner with multiple partners comes in complaining of mild abdominal pain and fever. She has no unusual discharge, but has cervical motion tenderness. What would you do and why?

Treat her with antibiotics. Advise her that she can keep the IUD while undergoing treatment, if she so desires. Treat her partner also, if possible. Encourage use of condoms to protect against STIs. Reevaluate in 72 hours.

MIDCOURSE QUESTIONNAIRE

USING THE QUESTIONNAIRE

This knowledge assessment is designed to help the participants monitor their progress during the course. By the end of the course, **all** participants are expected to achieve a score of 85% or better.

The questionnaire should be given at the time in the course when all subject areas have been presented. A score of 85% or more correct indicates knowledge-based mastery of the material presented in the reference manual. For those scoring less than 85% on their first attempt, the clinical trainer should review the results with the participant individually and guide her/him on using the reference manual to learn the required information. Participants scoring less than 85% can retake the Questionnaire at any time during the remainder of the course.

Repeat testing should be done **only** after the participant has had sufficient time to study the reference manual.

MIDCOURSE QUESTIONNAIRE

Instructions: Select the single best answer to each question and write the letter in the blank next to the corresponding number on the attached answer sheet.

OVERVIEW

1. The IUD is the best choice for a woman who:
 - a. has painful menstrual periods
 - b. has AIDS and is not on antiretroviral (ARV) therapy
 - c. has heavy menstrual flow and anemia
 - d. wants many years of contraceptive protection

2. Which of the following is **TRUE** about the IUD?
 - a. The IUD itself does not increase the risk of pelvic infection
 - b. The IUD must be removed if a pelvic infection occurs
 - c. The IUD prevents pregnancy by destroying the fertilized egg
 - d. The IUD may never be used in women who are HIV-infected

3. Which one of the following is WHO category 3 for **insertion** (risks usually outweigh the benefits)?
 - a. woman is anemic
 - B. woman has rheumatic heart disease
 - c. woman has aids and is not on ARV therapy
 - d. woman has active chlamydia infection

COUNSELING

4. During counseling using the GATHER technique, it is important to:
 - a. tell the woman about every contraceptive method available
 - b. find out which method the woman is interested in
 - c. tell the woman not to worry about side effects
 - d. choose a method for the woman based on information gathered

5. The most important part of counseling is:
 - a. providing brochures about contraceptive methods to the woman for review with her partner
 - b. identifying the woman's concerns about using contraceptives and answering her questions
 - c. obtaining formal consent for any procedures involved from the client
 - d. describing health risks of the method to the client

6. Which of the following will make your education or client instructions most useful?
 - a. keep your messages simple
 - b. ask her repeat messages
 - c. focus on what she is interested in
 - d. all of the above

7. Postinsertion counseling should inform the woman of common side effects of IUD use, such as:
 - a. nausea (feeling sick) and headaches
 - b. heavy vaginal discharge requiring frequent personal hygiene (douching)
 - c. increased menstrual bleeding and cramping for first few months, possible spotting/light bleeding between periods, cramping/spotting for first few days
 - d. increased risk of heart disease or stroke

INFECTION PREVENTION

8. Surgical (metal) instruments that have been decontaminated and thoroughly cleaned can be high-level disinfected by:
 - a. using a dry-heat oven at 100°C for 20 minutes
 - b. soaking them for 30 minutes in fresh 1–3% iodine solution
 - c. boiling them for 20 minutes
 - d. exposure to ultraviolet light for 1 hour

9. Surgical (metal) instruments used for IUD insertion, (i.e., the vaginal speculum, uterine sound, and tenaculum) **can** be safely used if, after decontamination and thorough cleaning, they are:
 - a. dried and stored in a sterile container
 - b. high-level disinfected
 - c. soaked in Savlon or Zephiran for 30 minutes
 - d. used immediately

10. To make items safer to handle during the cleaning process, instruments and gloves **first** should be:
 - a. rinsed in water and scrubbed with a brush before disinfecting by boiling
 - b. soaked in 0.5% chlorine solution for 10 minutes before cleaning
 - c. rinsed in water and scrubbed with a brush before sterilizing
 - d. soaked overnight in 8% formaldehyde

11. Which antiseptic can be safely used for cervical or vaginal preparation?
 - a. 40% alcohols
 - b. .01% dilute chlorine solution
 - c. tincture of iodine
 - d. povidone iodine

CLIENT ASSESSMENT

12. When taking a history from a prospective IUD client, questions should include:
- menstrual history, parity, and previous STIs or pelvic infections
 - a description of past contraceptive use
 - whether a partner has current penile discharge
 - all of the above
13. Pelvic examination must be included in the examination of a prospective IUD client to:
- collect specimen for PAP smear
 - determine the shape, position, size, and consistency of the uterus
 - routinely collect specimens for wet mount
 - check for adnexal mass
14. One of the few conditions that contraindicate IUD insertion is:
- presence of trichomoniasis or monilia
 - current case of PID
 - PID that was treated 2 months ago
 - woman who is HIV-positive

IUD INSERTION AND REMOVAL

15. When may the IUD safely be inserted?
- any time during the menstrual cycle, provided the woman is not pregnant
 - immediately after a first trimester abortion or miscarriage
 - immediately postpartum (after 10 minutes, before 48 hours)
 - all of the above
16. Gentle inserting the IUD using the “no touch” technique:
- eliminates the need for sterile gloves
 - minimizes the risk of postinsertion infection
 - reduces the need for local anesthetic
 - all of the above
17. Reasons for removing the IUD include:
- if the woman wants to get pregnant
 - if the woman wants to have it removed
 - if there are persistent side effects or other problems
 - all of the above

18. The Copper T 380A should be removed/replaced in ___ years.

- a. 4 years
- b. 6 years
- c. 10 years
- d. 12 years

FOLLOW-UP CARE/MANAGEMENT OF POTENTIAL PROBLEMS

19. Following the insertion of the IUD, the woman should return to the clinic:

- a. after her next period/in 3 to 6 weeks (or at least within 3 months)
- b. every 6 months
- c. only if she is having a problem or wants to have it removed
- d. in 12 years (for Copper T 380A) to have it removed or replaced

20. If a woman becomes pregnant with an IUD in place she is more likely to:

- a. have a child with birth defects
- b. have increased vaginal discharge if the IUD is left in place
- c. develop a uterine infection if the IUD is left in place
- d. all of the above

MIDCOURSE QUESTIONNAIRE ANSWER SHEET

OVERVIEW

1. _____ Participant Objective 1 (Chapter 1)
2. _____ Participant Objective 2 (Chapter 1)
3. _____ Participant Objective 3 (Chapter 1)

COUNSELING

4. _____ Participant Objective 4 (Chapter 2)
5. _____ Participant Objective 4 (Chapter 2)
6. _____ Participant Objective 4 (Chapter 2)
7. _____ Participant Objectives 4, 9 (Chapters 2, 5)

INFECTION PREVENTION

8. _____ Participant Objective 5 (Chapter 3)
9. _____ Participant Objective 5 (Chapter 3)
10. _____ Participant Objective 5 (Chapter 3)
11. _____ Participant Objective 5 (Chapter 3)

CLIENT ASSESSMENT

12. _____ Participant Objective 6 (Chapter 4)
13. _____ Participant Objective 6 (Chapter 4)
14. _____ Participant Objective 6 (Chapter 4)

IUD INSERTION AND REMOVAL

15. _____ Participant Objective 8 (Chapter 5)
16. _____ Participant Objective 8 (Chapter 5)
17. _____ Participant Objectives 9–10 (Chapter 5)
18. _____ Participant Objectives 9–10 (Chapter 5)

(continued on reverse)

FOLLOW-UP CARE/MANAGEMENT OF POTENTIAL PROBLEMS

19. ____ Participant Objective 12 (Chapter 6)

20. ____ Participant Objective 12 (Chapter 6)

MIDCOURSE QUESTIONNAIRE ANSWER KEY

OVERVIEW

1. The IUD is the best choice for a woman who:
 - a. has painful menstrual periods
 - b. has AIDS and is not on antiretroviral (ARV) therapy
 - c. has heavy menstrual flow and anemia
 - D. WANTS MANY YEARS OF CONTRACEPTIVE PROTECTION**

2. Which of the following is **TRUE** about the IUD?
 - A. THE IUD ITSELF DOES NOT INCREASE THE RISK OF PELVIC INFECTION**
 - b. The IUD must be removed if a pelvic infection occurs
 - c. The IUD prevents pregnancy by destroying the fertilized egg
 - d. The IUD may never be used in women who are HIV-infected

3. Which one of the following is WHO category 3 for **insertion** (risks usually outweigh the benefits)?
 - a. woman is anemic
 - B. woman has rheumatic heart disease
 - C. WOMAN HAS AIDS AND IS NOT ON ARV THERAPY**
 - d. woman has active chlamydia infection

COUNSELING

4. During counseling using the GATHER technique, it is important to:
 - a. tell the woman about every contraceptive method available
 - B. FIND OUT WHICH METHOD THE WOMAN IS INTERESTED IN**
 - c. tell the woman not to worry about side effects
 - e. choose a method for the woman based on information gathered

5. The most important part of counseling is:
 - a. providing brochures about contraceptive methods to the woman for review with her partner
 - B. IDENTIFYING THE WOMAN'S CONCERNS ABOUT USING CONTRACEPTIVES AND ANSWERING HER QUESTIONS**
 - c. obtaining formal consent for any procedures involved from the client
 - d. describing health risks of the method to the client

6. Which of the following will make your education or client instructions most useful?
- e. keep your messages simple
 - f. ask her repeat messages
 - g. focus on what she is interested in
 - D. ALL OF THE ABOVE**
7. Postinsertion counseling should inform the woman of common side effects of IUD use, such as:
- a. nausea (feeling sick) and headaches
 - b. heavy vaginal discharge requiring frequent personal hygiene (douching)
 - C. INCREASED MENSTRUAL BLEEDING AND CRAMPING FOR FIRST FEW MONTHS, POSSIBLE SPOTTING/LIGHT BLEEDING BETWEEN PERIODS, CRAMPING/SPOTTING FOR FIRST FEW DAYS**
 - d. increased risk of heart disease or stroke

INFECTION PREVENTION

8. Surgical (metal) instruments that have been decontaminated and thoroughly cleaned can be high-level disinfected by:
- a. using a dry-heat oven at 100°C for 20 minutes
 - b. soaking them for 30 minutes in fresh 1–3% iodine solution
 - C. BOILING THEM FOR 20 MINUTES**
 - d. exposure to ultraviolet light for 1 hour
9. Surgical (metal) instruments used for IUD insertion, (i.e., the vaginal speculum, uterine sound, and tenaculum) **can** be safely used if, after decontamination and thorough cleaning, they are:
- a. dried and stored in a sterile container
 - B. HIGH-LEVEL DISINFECTED**
 - c. soaked in Savlon or Zephiran for 30 minutes
 - d. used immediately
10. To make items safer to handle during the cleaning process, instruments and gloves **first** should be:
- a. rinsed in water and scrubbed with a brush before disinfecting by boiling
 - B. SOAKED IN 0.5% CHLORINE SOLUTION FOR 10 MINUTES BEFORE CLEANING**
 - c. rinsed in water and scrubbed with a brush before sterilizing
 - d. soaked overnight in 8% formaldehyde

11. Which antiseptic can be safely used for cervical or vaginal preparation?
- a. 40% alcohols
 - b. .01% dilute chlorine solution
 - c. tincture of iodine
 - D. POVIDONE IODINE**

CLIENT ASSESSMENT

12. When taking a history from a prospective IUD client, questions should include:
- a. menstrual history, parity, and previous STIs or pelvic infections
 - b. a description of past contraceptive use
 - c. whether a partner has current penile discharge
 - D. ALL OF THE ABOVE**
13. Pelvic examination must be included in the examination of a prospective IUD client to:
- a. collect specimen for PAP smear
 - B. DETERMINE THE SHAPE, POSITION, SIZE, AND CONSISTENCY OF THE UTERUS**
 - c. routinely collect specimens for wet mount
 - d. check for adnexal mass
14. One of the few conditions that contraindicate IUD insertion is:
- a. presence of trichomoniasis or monilia
 - B. CURRENT CASE OF PID**
 - c. PID that was treated 2 months ago
 - d. woman who is HIV-positive

IUD INSERTION AND REMOVAL

15. When may the IUD safely be inserted?
- a. any time during the menstrual cycle, provided the woman is not pregnant
 - b. immediately after a first trimester abortion or miscarriage
 - c. immediately postpartum (after 10 minutes, before 48 hours)
 - D. ALL OF THE ABOVE**
16. Gentle inserting the IUD using the “no touch” technique:
- a. eliminates the need for sterile gloves
 - b. minimizes the risk of postinsertion infection
 - c. reduces the need for local anesthetic
 - D. ALL OF THE ABOVE**

17. Reasons for removing the IUD include:

- a. if the woman wants to get pregnant
- b. if the woman wants to have it removed
- c. if there are persistent side effects or other problems
- D. ALL OF THE ABOVE**

18. The Copper T 380A should be removed/replaced in __ years.

- a. 4 years
- b. 6 years
- c. 10 years
- D. 12 YEARS**

FOLLOW-UP CARE/MANAGEMENT OF POTENTIAL PROBLEMS

19. Following the insertion of the IUD, the woman should return to the clinic:

- A. AFTER HER NEXT PERIOD/IN 3 TO 6 WEEKS (OR AT LEAST WITHIN 3 MONTHS)**
- b. every 6 months
- c. only if she is having a problem or wants to have it removed
- h. in 12 years (for Copper T 380A) to have it removed or replaced

20. If a woman becomes pregnant with an IUD in place she is more likely to:

- a. have a child with birth defects
- b. have increased vaginal discharge if the IUD is left in place
- C. DEVELOP A UTERINE INFECTION IF THE IUD IS LEFT IN PLACE**
- d. all of the above

CHECKLIST FOR IUD COUNSELING AND CLINICAL SKILLS

USING THE CHECKLIST

The **Checklist for IUD Counseling and Clinical Skills** is used by the clinical trainer to evaluate each participant's performance in providing IUD services to clients (i.e., counseling, client screening, infection prevention practices, insertion, and removal). This checklist is derived from the information provided in the IUD reference manual as well as that in the training slide set and the learning guides. Unlike the learning guides, which are quite detailed with the counseling activities and insertion and removal skills separated, the checklist focuses on the **key** steps in the entire process.

Criteria for satisfactory performance by the participant are based on the knowledge, attitudes, and skills set forth in the reference manual and learning guides.

Satisfactory: Performs the step or task according to the standard procedure or guidelines.

Unsatisfactory: Unable to perform the step or task according to the standard procedure or guidelines.

Not Observed: Step, task or skill not performed by participant during evaluation by trainer.

Note: There are two checklists included in this notebook:

- One adapted for the Regular Copper T 380A
- Another adapted for the TCU 380A with Safe Load

Participants also have three versions of the

Evaluation of the **counseling skills** of each participant may be done with clients. It may, however, also be accomplished through observation during role plays with volunteers or clients in real situations at any time during the course.

Evaluation of **clinical skills** usually will be done during the last 3 days of the course (depending on class size and client caseload). In a participant's first few cases, it is not mandatory (or even possible) for the trainer to observe the participant performing a procedure from beginning to end. For example, early on, s/he may watch the participant load the IUD in the sterile package in one case, insert the IUD in another, and decontaminate instruments in yet a third. What is important is that each participant demonstrate the steps or tasks at least once for feedback and coaching prior to the final evaluation. (If a step or task is not done correctly, the participant should repeat the entire skill or activity sequence, **not** just the incorrect step.) In addition, it is recommended that the clinical trainer not stop the participant at the incorrect step unless the safety of the client is at stake. If it is not, the clinical trainer should allow her/him to finish the skill/activity before providing coaching and feedback on her/his overall performance.

In determining whether the participant is qualified, the clinical trainer(s) will observe and rate the participant's performance on each step of a skill or activity. The participant must be rated "Satisfactory" for each skill/activity group covered in the checklist in order to be evaluated as qualified.

Finally, during the course, it is the clinical trainer's responsibility to observe each participant's overall performance in providing IUD services. Only by doing this can the clinical trainer assess the way the participant uses what s/he has learned (e.g., her/his attitude toward clients). This provides a key opportunity to observe the impact of the participant's **attitude** on clients—a critical component of quality service delivery.

Qualification

The number of procedures each participant needs to observe, assist with, and perform will vary depending on her/his previous training and experience as well as how the current training is being conducted (e.g., whether models are being used for initial skill acquisition). The number of clinical cases needed must be assessed on an individual basis; there is no "magic number" of cases that automatically makes a person qualified to provide IUD services.

When anatomic models are used for initial skill acquisition, nearly all participants will be judged to be competent after only two to four cases. Proficiency, however, invariably requires additional practice. Therefore, in training of participants who will become **new** IUD service providers (i.e., participants without prior training or experience), each participant may need to provide IUD services to at least 5 to 10 clients in order to "feel confident" about her/his skills. Thus, in the final analysis, the judgment of a skilled clinical trainer is the most important factor in determining competence (i.e., whether the participant is qualified).

The goal of this training is to enable **every** participant to achieve competency (i.e., be qualified to provide IUD services). Therefore, if additional practice in, for example, counseling or IUD insertion is needed, sufficient extra cases should be allocated during the course to ensure that the participant is qualified. Finally, once qualified, each participant should have the opportunity to apply her/his new knowledge and skills as soon as possible. Failure to do so quickly leads to loss of **provider confidence** and ultimately **loss of competence**.

CHECKLIST FOR IUD COUNSELING AND CLINICAL SKILLS

(ADAPTED FOR THE REGULAR COPPER T 380A)

(To be completed by the Trainers)

Place a “✓” in case box of step/task is performed satisfactorily, an “X” if it is not performed satisfactorily, or **N/O** if not observed.

Satisfactory: Performs the step or task according to the standard procedure or guidelines

Unsatisfactory: Unable to perform the step or task according to the standard procedure or guidelines

Not Observed: Step, task or skill not performed by participant during evaluation by trainer

Participant _____ Course Dates _____

CHECKLIST FOR IUD COUNSELING AND CLINICAL SKILLS (REGULAR COPPER T 380A)					
STEP/TASK	CASES				
METHOD-SPECIFIC COUNSELING					
1. Once the woman has chosen to use the IUD, assess her knowledge of the method.					
2. Ensure that she knows that menstrual changes are a common side effect among IUD users, and that the IUD does not protect against STIs.					
3. Describe the medical assessment required before IUD insertion, as well as the procedures for IUD insertion and removal.					
4. Encourage her to ask questions. Provide additional information and reassurance as needed.					
SKILL/ACTIVITY PERFORMED SATISFACTORILY					
IUD INSERTION					
Client Assessment (Use Appendix B to confirm that the woman is eligible for IUD use.)					
1. Review the client’s medical and reproductive history.					
2. Ensure that equipment and supplies are available and ready to use.					
3. Have the client empty her bladder and wash her perineal area.					
4. Help the client onto the examination table.					
5. Tell the client what is going to be done, and ask her if she has any questions.					
6. Wash hands thoroughly and dry them.					
7. Palpate the abdomen .					
8. Wash hands thoroughly and dry them <u>again</u> .					
9. Put clean or HLD gloves on both hands.					
10. Inspect the external genitalia.					
Note:					
<ul style="list-style-type: none"> ● If findings are normal, perform the bimanual exam first and the speculum exam second. ● If there are potential problems, perform the speculum exam first and a bimanual exam second. 					
11a. Perform a bimanual exam (see Note above)					
11b. Perform rectovaginal exam only if indicated.					
11c. If rectovaginal exam is performed, change gloves before continuing.					

CHECKLIST FOR IUD COUNSELING AND CLINICAL SKILLS (REGULAR COPPER T 380A)					
STEP/TASK	CASES				
12. Perform a speculum exam (see Note above). (Note: If laboratory testing is indicated and available, take samples now.)					
SKILL/ACTIVITY PERFORMED SATISFACTORILY					
Preinsertion and Insertion Steps (Using aseptic, “no touch” technique throughout)					
1. Provide an overview of the insertion procedure. Remind her to let you know if she feels any pain.					
2. Gently insert the HLD (or sterile) speculum to visualize the cervix (if not already done), and cleanse the cervical os and vaginal wall with antiseptic.					
3. Gently grasp the cervix with an HLD (or sterile) tenaculum and apply gentle traction.					
4. Insert the HLD (or sterile) sound using the “no touch” technique.					
5. Load the IUD in its sterile package.					
6. Set the blue depth-gauge to the measurement of the uterus.					
7. Carefully insert the loaded IUD, and release it into the uterus using the “withdrawal” technique.					
8. Gently push the insertion tube upward again until you feel a slight resistance.					
9. Withdraw the rod, and partially withdraw the insertion tube until the IUD strings can be seen.					
10. Use HLD (or sterile) sharp Mayo scissors to cut the IUD strings to 3–4 cm length.					
11. Gently remove the tenaculum and speculum and place in 0.5% chlorine solution for 10 minutes for decontamination..					
12. Examine the cervix for bleeding.					
13. Ask how the client is feeling and begin performing the postinsertion steps.					
SKILL/ACTIVITY PERFORMED SATISFACTORILY					
Postinsertion Steps					
1. Before removing the gloves, place all used instruments in 0.5% chlorine solution for 10 minutes for decontamination.					
2. Properly dispose of waste materials.					
3. Process gloves according to recommended IP practices.					
4. Wash hands thoroughly and dry them.					
5. Provide postinsertion instructions (key messages for IUD users): <ul style="list-style-type: none"> ● Basic facts about her IUD (e.g., type, how long effective, when to replace/remove) ● No protection against STIs; need for condoms if at risk ● Possible side effects ● Warning signs (PAINS) ● Checking for possible IUD expulsion ● When to return to clinic 					
SKILL/ACTIVITY PERFORMED SATISFACTORILY					
IUD REMOVAL					
Preremoval Steps					
1. Ask the woman her reason for having the IUD removed.					
2. Determine whether she will have another IUD inserted immediately, start a different method, or neither.					
3. Review the client’s reproductive goals and need for STI protection, and counsel as appropriate.					

CHECKLIST FOR IUD COUNSELING AND CLINICAL SKILLS (REGULAR COPPER T 380A)					
STEP/TASK	CASES				
4. Ensure that equipment and supplies are available and ready to use.					
5. Have the client empty her bladder and wash her perineal area.					
6. Help the client onto the examination table.					
7. Wash hands thoroughly and dry them.					
8. Put new or HLD gloves on both hands.					
SKILL/ACTIVITY PERFORMED SATISFACTORILY					
Removing the IUD					
1. Provide an overview of the insertion procedure. Remind her to let you know if she feels any pain.					
2. Gently insert the HLD (or sterile) speculum to visualize the strings, and cleanse the cervical os and vaginal wall with antiseptic.					
3. Alert the client immediately before you remove the IUD.					
4. Grasp the IUD strings close to the cervix with an HLD (or sterile) hemostat or other narrow forceps.					
5. Apply steady but gentle traction, pulling the strings toward you, to remove the IUD. Do not use excessive force.					
6. Show the IUD to client.					
7. Place the IUD in 0.5% chlorine solution for 10 minutes for decontamination.					
8. If the woman is having a new IUD inserted, insert it now if appropriate. [If she is not having a new IUD inserted, gently remove the speculum and place it in 0.5% chlorine solution for 10 minutes for decontamination.]					
9. Ask how the client is feeling and begin performing the postremoval steps.					
SKILL/ACTIVITY PERFORMED SATISFACTORILY					
Postremoval Steps					
1. Before removing the gloves, place all used instruments and the IUD in 0.5% chlorine solution for 10 minutes for decontamination.					
2. Properly dispose of waste materials.					
3. Process gloves according to recommended IP practices.					
4. Wash hands thoroughly and dry them.					
5. If the woman has had a new IUD inserted, review key messages for IUD users. [If the woman is starting a different method, provide the information she needs to use it safely and effectively (and a back-up method, if needed).]					
SKILL/ACTIVITY PERFORMED SATISFACTORILY					

PARTICIPANT IS **QUALIFIED** **NOT QUALIFIED** TO DELIVER IUD SERVICES, BASED ON THE FOLLOWING CRITERIA:

- Score on Midcourse Questionnaire _____% (Attach Answer Sheet)
- Counseling and Clinical Skills Evaluation: Satisfactory Unsatisfactory
- Provision of services (practice): Satisfactory Unsatisfactory

Trainer's Signature _____ **Date** _____

CHECKLIST FOR IUD COUNSELING AND CLINICAL SKILLS

(ADAPTED FOR THE TCU 380A WITH SAFE LOAD)

(To be completed by the Trainers)

Place a “✓” in case box of step/task is performed satisfactorily, an “X” if it is not performed satisfactorily, or **N/O** if not observed.

Satisfactory: Performs the step or task according to the standard procedure or guidelines

Unsatisfactory: Unable to perform the step or task according to the standard procedure or guidelines

Not Observed: Step, task or skill not performed by participant during evaluation by trainer

Participant _____ Course Dates _____

CHECKLIST FOR IUD COUNSELING AND CLINICAL SKILLS (TCU 380A WITH SAFE LOAD)					
STEP/TASK	CASES				
METHOD-SPECIFIC COUNSELING					
1. Once the woman has chosen to use the IUD, assess her knowledge of the method.					
2. Ensure that she knows that menstrual changes are a common side effect among IUD users, and that the IUD does not protect against STIs.					
3. Describe the medical assessment required before IUD insertion, as well as the procedures for IUD insertion and removal.					
4. Encourage her to ask questions. Provide additional information and reassurance as needed.					
SKILL/ACTIVITY PERFORMED SATISFACTORILY					
IUD INSERTION					
Client Assessment (Use Appendix B to confirm that the woman is eligible for IUD use.)					
1. Review the client’s medical and reproductive history.					
2. Ensure that equipment and supplies are available and ready to use.					
3. Have the client empty her bladder and wash her perineal area.					
4. Help the client onto the examination table.					
5. Tell the client what is going to be done, and ask her if she has any questions.					
6. Wash hands thoroughly and dry them.					
7. Palpate the abdomen .					
8. Wash hands thoroughly and dry them <u>again</u> .					
9. Put clean or HLD gloves on both hands.					
10. Inspect the external genitalia.					
Note:					
<ul style="list-style-type: none"> ● If findings are normal, perform the bimanual exam first and the speculum exam second. ● If there are potential problems, perform the speculum exam first and a bimanual exam second. 					
11a. Perform a bimanual exam (see Note above)					
11b. Perform rectovaginal exam only if indicated.					
11c. If rectovaginal exam is performed, change gloves before continuing.					

CHECKLIST FOR IUD COUNSELING AND CLINICAL SKILLS (TCU 380A WITH SAFE LOAD)					
STEP/TASK	CASES				
12. Perform a speculum exam (see Note above). (Note: If laboratory testing is indicated and available, take samples now.)					
SKILL/ACTIVITY PERFORMED SATISFACTORILY					
Preinsertion and Insertion Steps (Using aseptic, “no touch” technique throughout)					
1. Provide an overview of the insertion procedure. Remind her to let you know if she feels any pain.					
2. Gently insert the HLD (or sterile) speculum to visualize the cervix (if not already done), and cleanse the cervical os and vaginal wall with antiseptic.					
3. Gently grasp the cervix with an HLD (or sterile) tenaculum and apply gentle traction.					
4. Insert the HLD (or sterile) sound using the “no touch” technique.					
5. Load the IUD in its sterile package.					
6. Set the blue depth-gauge to the measurement of the uterus.					
7. Carefully insert the loaded IUD, and release it into the uterus using the “withdrawal” technique.					
8. Gently push the insertion tube upward again until you feel a slight resistance.					
9. Withdraw the rod, and partially withdraw the insertion tube until the IUD strings can be seen.					
10. Use HLD (or sterile) sharp Mayo scissors to cut the IUD strings to 3–4 cm length.					
11. Gently remove the tenaculum and speculum and place in 0.5% chlorine solution for 10 minutes for decontamination..					
12. Examine the cervix for bleeding.					
13. Ask how the client is feeling and begin performing the postinsertion steps.					
SKILL/ACTIVITY PERFORMED SATISFACTORILY					
Postinsertion Steps					
1. Before removing the gloves, place all used instruments in 0.5% chlorine solution for 10 minutes for decontamination.					
2. Properly dispose of waste materials.					
3. Process gloves according to recommended IP practices.					
4. Wash hands thoroughly and dry them.					
5. Provide postinsertion instructions (key messages for IUD users): <ul style="list-style-type: none"> ● Basic facts about her IUD (e.g., type, how long effective, when to replace/remove) ● No protection against STIs; need for condoms if at risk ● Possible side effects ● Warning signs (PAINS) ● Checking for possible IUD expulsion ● When to return to clinic 					
SKILL/ACTIVITY PERFORMED SATISFACTORILY					
IUD REMOVAL					
Preremoval Steps					
1. Ask the woman her reason for having the IUD removed.					
2. Determine whether she will have another IUD inserted immediately, start a different method, or neither.					
3. Review the client’s reproductive goals and need for STI protection, and counsel as appropriate.					

CHECKLIST FOR IUD COUNSELING AND CLINICAL SKILLS (TCU 380A WITH SAFE LOAD)					
STEP/TASK	CASES				
4. Ensure that equipment and supplies are available and ready to use.					
5. Have the client empty her bladder and wash her perineal area.					
6. Help the client onto the examination table.					
7. Wash hands thoroughly and dry them.					
8. Put new or HLD gloves on both hands.					
SKILL/ACTIVITY PERFORMED SATISFACTORILY					
Removing the IUD					
1. Provide an overview of the insertion procedure. Remind her to let you know if she feels any pain.					
2. Gently insert the HLD (or sterile) speculum to visualize the strings, and cleanse the cervical os and vaginal wall with antiseptic.					
3. Alert the client immediately before you remove the IUD.					
4. Grasp the IUD strings close to the cervix with an HLD (or sterile) hemostat or other narrow forceps.					
5. Apply steady but gentle traction, pulling the strings toward you, to remove the IUD. Do not use excessive force.					
6. Show the IUD to client.					
7. Place the IUD in 0.5% chlorine solution for 10 minutes for decontamination.					
8. If the woman is having a new IUD inserted, insert it now if appropriate. [If she is not having a new IUD inserted, gently remove the speculum and place it in 0.5% chlorine solution for 10 minutes for decontamination.]					
9. Ask how the client is feeling and begin performing the postremoval steps.					
SKILL/ACTIVITY PERFORMED SATISFACTORILY					
Postremoval Steps					
1. Before removing the gloves, place all used instruments and the IUD in 0.5% chlorine solution for 10 minutes for decontamination.					
2. Properly dispose of waste materials.					
3. Process gloves according to recommended IP practices.					
4. Wash hands thoroughly and dry them.					
5. If the woman has had a new IUD inserted, review key messages for IUD users. [If the woman is starting a different method, provide the information she needs to use it safely and effectively (and a back-up method, if needed).]					
SKILL/ACTIVITY PERFORMED SATISFACTORILY					

PARTICIPANT IS **QUALIFIED** **NOT QUALIFIED** TO DELIVER IUD SERVICES, BASED ON THE FOLLOWING CRITERIA:

- Score on Midcourse Questionnaire _____% (Attach Answer Sheet)
- Counseling and Clinical Skills Evaluation: Satisfactory Unsatisfactory
- Provision of services (practice): Satisfactory Unsatisfactory

Trainer's Signature _____ **Date** _____

CHECKLIST FOR IUD COUNSELING AND CLINICAL SKILLS

(ADAPTED FOR THE MULTILOAD CU375)

(To be completed by the Trainers)

Place a “✓” in case box of step/task is performed satisfactorily, an “X” if it is not performed satisfactorily, or **N/O** if not observed.

Satisfactory: Performs the step or task according to the standard procedure or guidelines

Unsatisfactory: Unable to perform the step or task according to the standard procedure or guidelines

Not Observed: Step, task or skill not performed by participant during evaluation by trainer

Participant _____ Course Dates _____

CHECKLIST FOR IUD COUNSELING AND CLINICAL SKILLS (MULTILOAD CU375)					
STEP/TASK	CASES				
METHOD-SPECIFIC COUNSELING					
1. Once the woman has chosen to use the IUD, assess her knowledge of the method.					
2. Ensure that she knows that menstrual changes are a common side effect among IUD users, and that the IUD does not protect against STIs.					
3. Describe the medical assessment required before IUD insertion, as well as the procedures for IUD insertion and removal.					
4. Encourage her to ask questions. Provide additional information and reassurance as needed.					
SKILL/ACTIVITY PERFORMED SATISFACTORILY					
IUD INSERTION					
Client Assessment (Use Appendix B to confirm that the woman is eligible for IUD use.)					
1. Review the client’s medical and reproductive history.					
2. Ensure that equipment and supplies are available and ready to use.					
3. Have the client empty her bladder and wash her perineal area.					
4. Help the client onto the examination table.					
5. Tell the client what is going to be done, and ask her if she has any questions.					
6. Wash hands thoroughly and dry them.					
7. Palpate the abdomen .					
8. Wash hands thoroughly and dry them <u>again</u> .					
9. Put clean or HLD gloves on both hands.					
10. Inspect the external genitalia.					
Note:					
<ul style="list-style-type: none"> ● If findings are normal, perform the bimanual exam first and the speculum exam second. ● If there are potential problems, perform the speculum exam first and a bimanual exam second. 					
11a. Perform a bimanual exam (see Note above)					
11b. Perform rectovaginal exam only if indicated.					
11c. If rectovaginal exam is performed, change gloves before continuing.					

CHECKLIST FOR IUD COUNSELING AND CLINICAL SKILLS (MULTILOAD CU375)					
STEP/TASK	CASES				
12. Perform a speculum exam (see Note above). (Note: If laboratory testing is indicated and available, take samples now.)					
SKILL/ACTIVITY PERFORMED SATISFACTORILY					
Preinsertion and Insertion Steps (Using aseptic, “no touch” technique throughout)					
1. Provide an overview of the insertion procedure. Remind her to let you know if she feels any pain.					
2. Gently insert the HLD (or sterile) speculum to visualize the cervix (if not already done), and cleanse the cervical os and vaginal wall with antiseptic.					
3. Gently grasp the cervix with an HLD (or sterile) tenaculum and apply gentle traction.					
4. Insert the HLD (or sterile) sound using the “no touch” technique.					
5. Grasp the insertion tube and the IUD string together at the lower end of the tube.					
6. Move the cervical guard to the measurement of the uterus.					
7. Gently advance the loaded IUD into the uterine cavity until the cervical guard touches cervix or a slight resistance is felt					
8. Continuing to apply gentle downward traction to the tenaculum, remove the inserter tube from the cervical canal.					
9. Partially withdraw the insertion tube from the cervical canal until the string can be seen extending from the cervical os.					
10. Use HLD (or sterile) sharp Mayo scissors to cut the IUD strings to 3–4 cm length.					
11. Gently remove the tenaculum and speculum and place in 0.5% chlorine solution for 10 minutes for decontamination..					
12. Examine the cervix for bleeding.					
13. Ask how the client is feeling and begin performing the postinsertion steps.					
SKILL/ACTIVITY PERFORMED SATISFACTORILY					
Postinsertion Steps					
1. Before removing the gloves, place all used instruments in 0.5% chlorine solution for 10 minutes for decontamination.					
2. Properly dispose of waste materials.					
3. Process gloves according to recommended IP practices.					
4. Wash hands thoroughly and dry them.					
5. Provide postinsertion instructions (key messages for IUD users): <ul style="list-style-type: none"> ● Basic facts about her IUD (e.g., type, how long effective, when to replace/remove) ● No protection against STIs; need for condoms if at risk ● Possible side effects ● Warning signs (PAINS) ● Checking for possible IUD expulsion ● When to return to clinic 					
SKILL/ACTIVITY PERFORMED SATISFACTORILY					
IUD REMOVAL					
Preremoval Steps					
1. Ask the woman her reason for having the IUD removed.					
2. Determine whether she will have another IUD inserted immediately, start a different method, or neither.					

CHECKLIST FOR IUD COUNSELING AND CLINICAL SKILLS (MULTILOAD CU375)				
STEP/TASK	CASES			
3. Review the client's reproductive goals and need for STI protection, and counsel as appropriate.				
4. Ensure that equipment and supplies are available and ready to use.				
5. Have the client empty her bladder and wash her perineal area.				
6. Help the client onto the examination table.				
7. Wash hands thoroughly and dry them.				
8. Put new or HLD gloves on both hands.				
SKILL/ACTIVITY PERFORMED SATISFACTORILY				
Removing the IUD				
1. Provide an overview of the insertion procedure. Remind her to let you know if she feels any pain.				
2. Gently insert the HLD (or sterile) speculum to visualize the strings, and cleanse the cervical os and vaginal wall with antiseptic.				
3. Apply an HLD (or sterile) tenaculum to the cervix to straighten out the uterine axis.				
4. Alert the client immediately before you remove the IUD.				
5. Grasp the IUD strings close to the cervix with an HLD (or sterile) hemostat or other narrow forceps. With the Multiload, it is important to grasp the strings as close to the cervical os as possible.				
6. Show the IUD to client.				
7. Place the IUD in 0.5% chlorine solution for 10 minutes for decontamination.				
8. If the woman is having a new IUD inserted, insert it now if appropriate. [If she is not having a new IUD inserted, gently remove the speculum and place it in 0.5% chlorine solution for 10 minutes for decontamination.]				
9. Ask how the client is feeling and begin performing the postremoval steps.				
SKILL/ACTIVITY PERFORMED SATISFACTORILY				
Postremoval Steps				
1. Before removing the gloves, place all used instruments and the IUD in 0.5% chlorine solution for 10 minutes for decontamination.				
2. Properly dispose of waste materials.				
3. Process gloves according to recommended IP practices.				
4. Wash hands thoroughly and dry them.				
5. If the woman has had a new IUD inserted, review key messages for IUD users. [If the woman is starting a different method, provide the information she needs to use it safely and effectively (and a back-up method, if needed).]				
SKILL/ACTIVITY PERFORMED SATISFACTORILY				

PARTICIPANT IS **QUALIFIED** **NOT QUALIFIED** TO DELIVER IUD SERVICES, BASED ON THE FOLLOWING CRITERIA:

- Score on Midcourse Questionnaire _____% (Attach Answer Sheet)
- Counseling and Clinical Skills Evaluation: Satisfactory Unsatisfactory
- Provision of services (practice): Satisfactory Unsatisfactory

Trainer's Signature _____ Date _____

SECTION THREE: TIPS FOR TRAINERS

BEING AN EFFECTIVE CLINICAL TRAINER

Characteristics of an Effective Trainer and Coach	1
Skill Transfer and Assessment: The Coaching Process.....	2

CREATING A POSITIVE LEARNING ENVIRONMENT

Preparing for the Course	4
Understanding How People Learn.....	6
Using Effective Presentation Skills	9

CONDUCTING LEARNING ACTIVITIES

Delivering Interactive Presentations	11
Facilitating Group Discussions	14
Facilitating a Brainstorming Session	16
Facilitating Small Group Activities	17
Conducting an Effective Clinical Demonstration.....	19

TEACHING CLINICAL DECISION-MAKING

21

MANAGING CLINICAL PRACTICE

Performing Clinical Procedures with Clients.....	24
Creating Opportunities for Learning	25
Conducting Pre- and Post-Clinical Practice Meetings	27
The Trainer as Supervisor	29
The Trainer as Coach.....	30

BEING AN EFFECTIVE CLINICAL TRAINER

Health professionals conducting clinical training courses are continually changing roles. They are **trainers** or **instructors** when presenting illustrated lectures and giving classroom demonstrations. They act as **facilitators** when conducting small group discussions and using role plays, case studies, and clinical simulations. Once they have demonstrated a clinical procedure, they then shift to the role of the **coach** as the participants begin practicing.

CHARACTERISTICS OF AN EFFECTIVE TRAINER AND COACH

Coaching is a training technique in which the clinical trainer:

- **Describes** the skills and client interactions that the participant is expected to learn
- **Demonstrates** (models) the skill in a clear and effective manner using learning aids such as slide sets, videos, and anatomic models
- Provides detailed, specific feedback to participants as they practice the skills and client interactions using the anatomic model and actual instruments in a simulated clinical setting and as they provide services to clients

An effective **clinical trainer**:

- Is **proficient** in the skills to be taught
- **Encourages** participants in learning new skills
- Promotes open (two-way) communication
- Provides immediate feedback:
 - Informs participants whether they are meeting the objectives
 - Does not allow a skill or activity to be performed incorrectly
 - Gives positive feedback as often as possible
 - Avoids negative feedback and instead offers specific suggestions for improvement
- Is able to receive feedback:
 - **Asks for it.** Find clinical trainers who will be direct with you. Ask them to be specific and descriptive.
 - **Directs it.** If you need information to answer a question or pursue a learning goal, ask for it.

- **Accepts it.** Do not defend or justify your behavior. Listen to what people have to say and thank them. Use what is helpful; quietly discard the rest.
- Recognizes that training can be stressful and knows how to **regulate participant as well as trainer stress:**
 - Uses appropriate humor
 - Observes participants and watches for signs of stress
 - Provides for regular breaks
 - Provides for changes in the training routine
 - Focuses on participant success as opposed to failure

The characteristics of an **effective coach** are the same as those of an **effective clinical trainer**. Additional characteristics especially important for the coach include:

- Being patient and supportive
- Providing praise and positive reinforcement
- Correcting participants' errors while maintaining participants' self-esteem
- Listening and observing

SKILL TRANSFER AND ASSESSMENT: THE COACHING PROCESS

The process of learning a clinical skill within the coaching process has three basic phases: demonstration, practice, and evaluation. These three phases can be broken down further into the following steps:

- First, during interactive classroom presentations, **explaining** the skill or activity to be learned
- Next, using a video or slide set, **showing** the skill or activity to be learned
- Following this, **demonstrating** the skill or activity using an anatomic model (if appropriate), role play (e.g., counseling demonstration) or clinical simulation
- Then, allowing the participants to **practice** the demonstrated skill or activity with an **anatomic model** or in a simulated environment (e.g., role play, clinical simulation) as the trainer functions as a coach
- After this, **reviewing** the practice session and giving constructive feedback

- After adequate practice, **assessing** each participant's performance of the skill or activity on models or in **a simulated situation**, using the competency-based checklist
- After competence is gained with models or practice in a simulated situation, having participants begin to **practice** the skill or activity with clients under a clinical trainer's guidance
- Finally, **evaluating** the participant's ability to perform the skill according to the standardized procedure as outlined in the competency-based checklist

During initial skill acquisition, the trainer demonstrates the skill as the participant observes. As the participant practices the skill, the trainer functions as a coach and observes and assesses performance. When demonstrating skill competency, the participant is now the person performing the skill as the trainer evaluates performance.

CREATING A POSITIVE LEARNING ENVIRONMENT

A successful training course does not come about by accident, but rather through careful planning. This planning takes thought, time, preparation, and often some study on the part of the clinical trainer. The trainer is responsible for ensuring that the course is carried out essentially as it was designed. The trainer must make sure that the clinical practice sessions, which are an integral part of a clinical skills course, as well as the classroom sessions, are conducted appropriately. In addition to taking responsibility for the organization of the course in general, the trainer must also be able to give presentations and demonstrations and lead other course activities, all of which require prior planning. Well-planned and executed classroom and clinical sessions will help to create a positive learning environment.

PREPARING FOR THE COURSE

To prepare for the course, the following steps are recommended:

- **Review the course syllabus**, including the course description, goals, learning methods, training materials, methods of evaluation, course duration, and suggested course composition.
- **Review the course schedule.**
- **Study the course outline.** The course outline provides detailed suggestions regarding the teaching of each objective and the facilitation of each activity. Based on suggestions in the course outline and the trainer's own ideas, the trainer will gather the necessary equipment, supplies, and materials. The trainer should also compare time estimates in the course outline to the schedule to ensure that sufficient time has been allotted for all sessions and activities.
- **Read and study the reference manual** to ensure complete familiarity with the content to be presented during the course.
- **Review the pre- and midcourse questionnaires** and make copies of the questionnaires, matrix, and answer sheets if needed.
- **Check all audiovisual equipment** (e.g., overhead projector, video player, flipchart stand).
- **Check all anatomic models** (e.g., are they clean and in good condition? are all parts in place?).
- **Practice all clinical procedures** using the anatomic model(s) and the learning guides and checklists found in the trainer's notebook and participant's handbook.

- **Obtain information about the participants who will be attending the course.** It is important for the clinical trainer to know basic information about participants such as:
 - The **experience and educational background** of the participants. The clinical trainer should attempt to gather as much information about participants as possible before training. If this is not possible, the trainer should inquire about their backgrounds and expectations during the first day of the course.
 - The types of **clinical activities** the participants will perform in their daily work after training. Knowing the exact nature of the work that participants will perform after training is critical for the clinical trainer. The trainer must use appropriate, job-specific examples throughout the course so that participants can draw connections between what is being taught and what they will need to do. This is an excellent way to reinforce the importance of what is being learned.
- **Prepare the classroom and make sure that:**
 - Tables arranged in a U-shape or other formation that will allow as many of the participants as possible to see one another and the trainer (this may be difficult in a lecture hall where chairs are attached to the floor).
 - A table in the front of the room where the trainers can place their course materials.
 - Space for audiovisual equipment (e.g., flipchart, screen, overhead projector, video player, monitor); the trainer should make sure that participants will be able to see the projection screen and other audiovisuals.
 - Space for participants to work in small groups (i.e., either arrange chairs in small circles or work around the tables), unless separate breakout rooms (see below) are available.
 - Space to set up simulated clinics (e.g., for activities with anatomic models or counseling practice).
 - Breakout rooms for small group work (e.g., case studies, role plays, clinical simulations, problem-solving activities) are available if necessary, and are set up with tables, chairs, and any materials that the participants will need.
 - The room is properly heated or cooled and ventilated.
 - The lighting is adequate, and the room can be darkened enough to show audiovisuals and still permit participants to take notes or follow along in their learning materials.
 - There will be adequate electric power throughout the course, and contingency plans have been made in case the power fails.

- Furniture such as tables, chairs, and desks is available. The chairs are comfortable and tablecloths are available.
- There is a writing board with chalk or marking pens, as well as an information board available for posting notes and messages for participants.
- There is audiovisual equipment in working order, with spare parts such as bulbs readily available. The video monitor is large enough so that all participants can see it well. There are sufficient electrical connections, and extension cords, electrical adaptors, and power strips (multi-plugs) are available, if necessary.
- There are toilet facilities that are adequately maintained.
- Telephones are accessible and in working order, and emergency messages can be taken.

UNDERSTANDING HOW PEOPLE LEARN

Establishing a positive learning climate depends on understanding how adults learn. The clinical trainer must have a clear understanding of what the participants need and expect, and the participants must have a clear understanding of why they are there. Adults who attend courses to acquire new knowledge, attitudes, and skills share the characteristics described below:

- Require learning to be **relevant**. The clinical trainer should offer participants learning experiences that **relate directly to their current or future job responsibilities**. At the beginning of the course, the objectives should be stated clearly and linked to job performance. The clinical trainer should take time to explain how each learning experience relates to the successful accomplishment of the course objectives.
- Are highly **motivated** if they believe learning is relevant. People bring **high levels of motivation and interest** to learning. Motivation can be increased and channeled by the clinical trainer who provides clear learning goals and objectives. To make the best use of a high level of participant interest, the clinical trainer should explore ways to incorporate the needs of each participant into the learning sessions. This means that the trainer needs to know quite a bit about the participants, either from studying background information about them or by allowing participants to talk early in the course about their experience and learning needs.
- Need **participation** and **active involvement** in the learning process. Few individuals prefer just to sit back and listen. The effective clinical trainer will design learning experiences that **actively involve the participants in the training process**. Examples of how the clinical trainer may involve participants include:

- Allowing participants to provide input regarding schedules, activities and other events
- Questioning and feedback
- Brainstorming and discussions
- Hands-on work
- Group and individual projects
- Classroom activities
- Desire a **variety** of learning experiences. The clinical trainer should use a variety of learning methods including:
 - Audiovisual aids
 - Illustrated lectures
 - Demonstrations
 - Brainstorming
 - Small group activities
 - Group discussions
 - Role plays, case studies and clinical simulations
- Desire **positive feedback**. Participants need to know **how they are doing**, particularly in light of the objectives and expectations of the course. Is their progress in learning clinical skills meeting the trainer's expectations? Is their level of clinical performance meeting the standards established for the procedure? **Positive feedback provides this information.** Learning experiences should be designed to move from the known to the unknown, or from simple activities to more complex ones. This progression provides positive experiences and feedback for the participant. To maintain positive feedback, the clinical trainer can:
 - Give verbal praise either in front of other participants or in private
 - Use positive responses during questioning
 - Recognize appropriate skills while coaching in a clinical setting
 - Let the participants know how they are progressing toward achieving learning objectives
- Have **personal concerns**. The clinical trainer must recognize that many participants fear failure and embarrassment in front of their colleagues. Participants often have concerns about their ability to:
 - Fit in with the other participants
 - Get along with the trainer
 - Understand the content of the training
 - Perform the skills being taught

- Need an **atmosphere of safety**. The clinical trainer should open the course with an introductory activity that will help participants feel at ease. It should communicate an atmosphere of safety so that participants do not judge one another or themselves. For example, a good introductory activity is one that acquaints participants with one another and helps them to associate the names of the other participants with their faces. Such an activity can be followed by learning experiences that support and encourage the participants.
- Need to be recognized as **individuals** with unique backgrounds, experiences, and learning needs. People want to be **treated as individuals**, each of whom has a unique background, experience, and learning needs. A person's past experiences is a good foundation upon which the clinical trainer can base new learning. To help ensure that participants feel like individuals, the clinical trainer should:
 - Use participants' names as often as possible
 - Involve all participants as often as possible
 - Treat participants with respect
 - Allow participants to share information with others during classroom and clinical instruction
- Must maintain their **self-esteem**. Participants need to **maintain high self-esteem** to deal with the demands of a clinical training course. Often the clinical methods used in training are different from clinical practices used in the participants' clinics. It is essential that the clinical trainer shows respect for the participants, no matter what practices and beliefs they hold to be correct, and continually support and challenge them. This requires the trainer to:
 - Reinforce those practices and beliefs embodied in the course content
 - Provide corrective feedback when needed, in a way that the participants can accept and use it with confidence and satisfaction
 - Provide training that adds to, rather than subtracts from, their sense of competence and self-esteem
 - Recognize participants' own career accomplishments
- Have **high expectations** for themselves and their trainer. People attending courses tend to set **high expectations both for the trainers and for themselves**. Getting to know their clinical trainers is a real and important need. Clinical trainers should be prepared to talk modestly, and within limits, about themselves, their abilities, and their backgrounds.

- Have **personal needs** that must be taken into consideration. All participants have **personal needs** during training. Taking timely breaks and providing the best possible ventilation, proper lighting, and an environment as free from distraction as possible can help to reduce tension and contribute to a positive learning atmosphere.

USING EFFECTIVE PRESENTATION SKILLS

It is also important to use effective presentation skills. Establishing and maintaining a positive learning climate during training depend on how the clinical trainer delivers information because the **trainer sets the tone** for the course. In any course, **how** something is said may be just as important as **what** is said. Some common techniques for effective presentations are listed below:

- **Follow a plan and use trainer's notes**, which include the session objectives, introduction, body, activity, audiovisual reminders, summary, and evaluation.
- **Communicate in a way that is easy to understand.** Many participants will be unfamiliar with the terms, jargon, and acronyms of a new subject. The clinical trainer should use familiar words and expressions, explain new language, and attempt to relate to the participants during the presentation.
- **Maintain eye contact with participants.** Use eye contact to “read” faces. This is an excellent technique for establishing rapport and getting feedback on how well participants understand the content.
- **Project your voice** so that those in the back of the room can hear clearly. Vary volume, voice pitch, tone, and inflection to maintain participants’ attention. Avoid using a monotone voice, which is guaranteed to put participants to sleep!
- **Avoid the use of slang or repetitive words, phrases, or gestures** that may become distracting with extended use.
- **Display enthusiasm about the topic and its importance.** Smile, move with energy, and interact with participants. The trainer’s enthusiasm and excitement are contagious and directly affect the morale of the participants.
- **Move around the room.** Moving around the room helps ensure that the trainer is close to each participant at some time during the session. Participants are encouraged to interact when the clinical trainer moves toward them and maintains eye contact.
- **Use appropriate audiovisual aids** during the presentation to reinforce key content or help simplify complex concepts.
- Be sure to ask both **simple and more challenging questions.**

- **Provide positive feedback** to participants during the presentation.
- **Use participants' names as often as possible.** This will foster a positive learning climate and help keep the participants focused on the presenter.
- Display a **positive use of humor** related to the topic (e.g., humorous stories, cartoons on transparency or flipchart, cartoons for which participants are asked to create captions).
- **Provide smooth transitions between topics.** Within a given presentation, a number of separate yet related topics may be discussed. When shifts between topics are abrupt, participants may become confused and lose sight of how the different topics fit together in the bigger picture. Before moving on to the next topic, the clinical trainer can ensure that the transition from one topic to the next is smooth by:
 - providing a brief summary;
 - asking a series of questions;
 - relating content to practice; or
 - using an application exercise (case study, role play, etc.).
- **Be an effective role model.** The clinical trainer should be a positive role model in appearance (appropriate dress) and attitude (enthusiasm for the course), and by beginning and ending the session at the scheduled times.

CONDUCTING LEARNING ACTIVITIES

Every presentation (training session) should begin with an **introduction** to capture participant interest and prepare the participant for learning. After the introduction, the clinical trainer may deliver content using an **illustrated lecture, demonstration, small group activity, or other learning activity**. Throughout the presentation, **questioning** techniques can be used to encourage interaction and maintain participant interest. Finally, the clinical trainer should conclude the presentation with a **summary** of the key points or steps.

DELIVERING INTERACTIVE PRESENTATIONS

Introducing Presentations

The first few minutes of any presentation are critical. Participants may be thinking about other matters, wondering what the session will be like, or have little interest in the topic. The **introduction** should:

- Capture the interest of the entire group and prepare participants for the information to follow
- Make participants aware of the trainer's expectations
- Help foster a positive learning climate

The clinical trainer can select from a number of techniques to provide variety and ensure that participants are not bored. Many introductory techniques are available, including:

- Reviewing the session objectives. Introducing the topic by a simple restatement of the objectives keeps the participant aware of what is expected of her/him.
- Asking a series of questions about the topic. The effective clinical trainer will recognize when participants have prior knowledge concerning the course content and encourage their contributions. The trainer can ask a few key questions, allow participants to respond, discuss answers and comments, and then move into the body of the presentation.
- Relating the topic to previously covered content. When a number of sessions are required to cover one subject, relate each session to previously covered content. This ensures that participants understand the continuity of the sessions and how each relates to the overall topic. Where possible, link topics so that the concluding review or summary of one presentation can introduce the next topic.
- **Sharing a personal experience.** There are times when the clinical trainer can share a personal experience to create interest, emphasize a point, or make a topic more job-related. Participants

enjoy hearing these stories as long as they relate to the topic and are used only when appropriate.

- **Relating the topic to real-life experiences.** Many training topics can be related to situations most participants have experienced. This technique not only catches the participants' attention, but also facilitates learning because people learn best by "anchoring" new information to known material. The experience may be from the everyday world or relate to a specific process or piece of equipment.
- **Using a case study, clinical simulation, or other problem-solving activity.** Problem-solving activities focus attention on a specific situation related to the training topic. Working in small groups generally increases interest in the topic.
- **Using a video or other audiovisual aid.** Use of appropriate audiovisuals can be stimulating and generate interest in a topic.
- **Giving a classroom demonstration.** Most clinical training courses involve equipment, instruments, and techniques that lend themselves to demonstrations, which generally increase participant interest.
- **Using a game, role play, or simulation.** Games, role plays, and simulations generate tremendous interest through direct participant involvement and therefore are useful for introducing topics.
- **Relating the topic to future work experiences.** Participants' interest in a topic will increase when they see a relationship between training and their work. The clinical trainer can capitalize on this by relating objectives, content, and activities of the course to real work situations.

Using Questioning Techniques

Questions can be used at anytime to:

- Introduce a topic
- Increase the effectiveness of the illustrated lecture
- Promote brainstorming
- Supplement the discussion process

Use a variety of questioning techniques to maintain interest and avoid a repetitive style.

- **Ask a question of the entire group.** The advantage of this technique is that those who wish to volunteer may do so; however, some participants may dominate while others may not participate.
- **Target the question to a specific participant by using her/his name prior to asking the question.** The participant is aware that a

question is coming, can concentrate on the question, and respond accordingly. The disadvantage is that once a specific participant is targeted, other participants may not concentrate on the question.

- **State the question, pause, and then direct the question to a specific participant.** All participants must listen to the question in the event that they are asked to respond. The primary disadvantage is that the participant receiving the question may be caught off guard and have to ask the trainer to repeat the question.

The key in asking questions is to avoid a pattern. The skilled clinical trainer uses all three of the above techniques to provide variety and maintain the participants' attention. Other techniques follow:

- **Use participants' names** during questioning. This is a powerful motivator and also helps ensure that all participants are involved.
- **Repeat a participant's correct response.** This provides positive reinforcement to the participant and ensures that the rest of the group heard the response.
- **Provide positive reinforcement for correct responses** to keep the participant involved in the topic. Positive reinforcement may take the form of praise, displaying a participant's work, using a participant as an assistant, or using positive facial expressions, nods, or other nonverbal actions.
- **When a participant's response is partially correct,** the clinical trainer should reward the correct portion and then improve the incorrect portion or redirect a related question to that participant or to another participant.
- **When a participant's response is incorrect,** the clinical trainer should make a noncritical response and restate the question to lead the participant to the correct response.
- **When a participant makes no attempt to respond,** the clinical trainer may wish to follow the above procedure or redirect the question to another participant. Come back to the first participant after receiving the desired response and involve her/him in the discussion.
- **When participants ask questions,** the clinical trainer must determine an appropriate response by drawing upon personal experience and weighing the individual's needs against those of the group. If the question addresses a topic that is relevant but has not been previously discussed, the clinical trainer can either:
 - answer the question and move on; or
 - respond with another question, thereby beginning a discussion about the topic.

Summarizing Presentations

A **summary** is used to reinforce the content of a presentation and provide a review of its main points. The summary should:

- Be brief
- Draw together the main points
- Involve the participants

Many summary techniques are available to the clinical trainer:

- **Asking the participants for questions** gives participants an opportunity to clarify their understanding of the instructional content. This may result in a lively discussion focusing on those areas that seem to be the most troublesome.
- **Asking the participants questions** that focus on major points of the presentation helps the participants summarize what they have just heard.
- **Administering a practice exercise or test** gives participants an opportunity to demonstrate their understanding of the material. After the exercise or test, use the questions as the basis for a discussion by asking for correct answers and explaining why each answer is correct.
- **Using a game to review main points** provides some variety, when time permits. One popular game is to divide participants into two teams, give each team time to develop review questions, and then allow each team to ask questions of the other. The clinical trainer serves as moderator by judging the acceptability of questions, clarifying answers and keeping a record of team scores. This game can be highly motivational and serve as an excellent summary at the same time.

FACILITATING GROUP DISCUSSIONS

The **group discussion** is a learning method in which most of the ideas, thoughts, questions, and answers are developed by the participants. The clinical trainer typically serves as the **facilitator** and guides the participants as the discussion develops.

Group discussion is useful:

- At the conclusion of a presentation
- After viewing a video
- Following a clinical demonstration or skills practice session
- After reviewing a case study or clinical simulation
- After a role play

- Any other time when participants have prior knowledge or experience related to the topic

Attempting to conduct a group discussion when participants have limited knowledge or experience with the topic often will result in little or no interaction and thus an ineffective discussion. When participants are familiar with the topic, the ensuing discussion is likely to **arouse participant interest, stimulate thinking, and encourage active participation**. This interaction affords the facilitator an opportunity to:

- Provide positive feedback
- Stress key points
- Develop critical thinking skills
- Create a positive learning climate

The facilitator must consider a number of factors when selecting group discussion as the learning strategy:

- Discussions involving **more than 15 to 20 participants** may be difficult to lead and may not give each participant an opportunity to participate.
- Discussion requires **more time** than an illustrated lecture because of extensive interaction among the participants.
- A **poorly directed discussion may move off target** and never reach the objectives established by the facilitator.
- **If control is not maintained**, a few participants may dominate the discussion while others lose interest.

In addition to a **group discussion** that focuses on the session objectives, there are two other types of discussions that may be used in a training situation:

- **General discussion** that addresses participants' questions about a learning event (e.g., why one type of episiotomy is preferred over another)
- **Panel discussion** in which a moderator conducts a question-and-answer session between panel members and participants

Follow these key points to ensure successful group discussion:

- **Arrange seating to encourage interaction** (e.g., tables and chairs set up in a U-shape or a square or circle so that participants face each other).
- **State the topic** as part of the introduction.
- **Shift the conversation** from the facilitator to the participants

- **Act as a referee** and intercede only when necessary.
Example: “It is obvious that Alain and Ilka are taking two sides in this discussion. Alain, let me see if I can clarify your position. You seem to feel that...”
- **Summarize the key points** of the discussion periodically.
Example: “Let’s stop here for a minute and summarize the main points of our discussion.”
- **Ensure that the discussion stays on the topic.**
- **Use the contributions of each participant** and provide positive reinforcement.
Example: “That is an excellent point, Rosminah. Thank you for sharing that with the group.”
- **Minimize arguments** among participants.
- **Encourage all participants to get involved.**
- **Ensure that no single participant dominates the discussion.**
- **Conclude the discussion with a summary** of the main ideas. The facilitator must relate the summary to the objective presented during the introduction.

FACILITATING A BRAINSTORMING SESSION

Brainstorming is a learning strategy that **stimulates thought and creativity** and is often used in conjunction with group discussions. The primary purpose of brainstorming is to generate a list of ideas, thoughts, or alternative solutions that focus on a specific topic or problem. This list may be used as the introduction to a topic or form the basis of a group discussion. Brainstorming requires that participants have some background related to the topic.

The following guidelines will facilitate the use of brainstorming:

- **Establish ground rules.**
Example: “During this brainstorming session we will be following two basic rules. All ideas will be accepted and Jim will write them on the flipchart. Also, at no time will we discuss or criticize any idea. Later, after we have our list of suggestions, we will go back and discuss each one. Are there any questions? If not. . . .”
- **Announce the topic or problem.**
Example: “During the next few minutes we will be brainstorming and will follow our usual rules. Our topic today is ‘Indications for cesarean section.’ I would like each of you to think of at least one

indication. Maria will write these on the board so that we can discuss them later. Who would like to be first? Yes, Ilka. . . .”

- **Maintain a written record** of the ideas and suggestions on a flipchart or writing board. This will prevent repetition and keep participants focused on the topic. In addition, this written record is useful when it is time to discuss each item.
- **Involve the participants and provide positive feedback** in order to encourage more input.
- **Review written ideas and suggestions periodically** to stimulate additional ideas.
- **Conclude brainstorming by reviewing all of the suggestions** and clarifying those that are acceptable.

FACILITATING SMALL GROUP ACTIVITIES

There are many times during training that the participants will be divided into several **small groups**, which usually consist of four to six participants. Examples of small group activities include:

- **Reacting to a case study**, which may be presented in writing or orally by the clinical trainer, or introduced through video or slides
- **Preparing a role play** within the small group and presenting it to the entire group as a whole
- **Dealing with a clinical situation/scenario**, such as in a **clinical simulation**, which has been presented by the clinical trainer or another participant
- **Practicing a skill** that has been demonstrated by the clinical trainer using anatomic models

Small group activities offer many advantages including:

- Providing participants an opportunity to **learn from each other**
- **Involving** all participants
- Creating a sense of **teamwork** among members as they get to know each other
- Providing for a **variety of viewpoints**

When small group activities are being conducted, it is important that participants are not in the same group every time. Different ways the clinical trainer can create small groups include:

- **Assigning** participants to groups
- Asking participants to **count off** “1, 2, 3,” etc. and having all the “1s” meet together, all the “2s” meet together, etc.

- Asking participants to **form their own groups**
- Asking participants to **draw a group number** (or group name)

The room(s) used for small group activities should be large enough to allow different arrangements of tables, chairs, and teaching aids (models, equipment) so that individual groups can work without disturbing one another. The clinical trainer should be able to move easily about the room to visit each group. If available, consider using smaller rooms near the primary training room where small groups can go to work on their problem-solving activity, case studies, clinical simulations, or role plays. Note that it will be difficult to conduct more than one clinical simulation at the same time in the same room/area.

Activities assigned to small groups should be **challenging, interesting, and relevant**; should require **only a short time to complete**; and should be **appropriate for the background of the participants**. Each small group may be working on the same activity or each group may be taking on a different problem, case study, clinical simulation, or role play. Regardless of the type of activity, there is usually a time limit. When this is the case, inform groups when there are 5 minutes left and when their time is up.

Instructions to the groups may be presented:

- In a handout
- On a flipchart
- On a transparency
- Verbally by the clinical trainer

Instructions for small group activities typically include:

- **Directions**
- **Time limit**
- A **situation or problem** to discuss, resolve or role play
- Participant **roles** (if a role play)
- **Questions** for a group discussion

Once the groups have completed their activity, the clinical training facilitator will **bring them together** as a large group for a discussion of the activity. This discussion might involve:

- **Reports** from each group
- **Responses** to questions
- **Role plays** developed in each group and presented by participants in the small groups

- **Recommendations** from each group
- **Discussion of the experience** (if a clinical simulation)

It is important that the clinical trainer provide an effective summary discussion following small group activities. This provides closure and ensures that participants understand the point of the activity.

CONDUCTING AN EFFECTIVE CLINICAL DEMONSTRATION

When a new clinical skill is being introduced, a variety of methods can be used to demonstrate the procedure. For example:

- Show **slides** or a **video** in which the steps and their sequence are demonstrated in accordance with the accepted performance standards.
- Use **anatomic models** such as the childbirth simulator to demonstrate the procedure and skills.
- Perform **role plays** in which a participant or surrogate client simulates a client and responds much as a real client would.
- Demonstrate the procedure with **clients** in the clinical setting (clinic or hospital).

Whatever methods are used to demonstrate the procedure, the clinical trainer should set up the activities using the “**whole-part-whole**” approach.

- Demonstrate the **whole procedure** from beginning to end to give the participant a visual image of the entire procedure or activity.
- **Isolate or break down the procedure** into activities (e.g., pre-operative counseling, getting the client ready, pre-operative tasks, performing the procedure, etc.) and allow practice of the individual activities of the procedure.
- Demonstrate the **whole procedure** again and then allow participants to practice the procedure from beginning to end.

When planning and giving a demonstration of a clinical procedure, either using anatomic models or with clients, if appropriate, the clinical trainer should use the following guidelines:

- Before beginning, **state the objectives** of the demonstration and point out what the participants should do (e.g., interrupt with questions, observe carefully, etc.).
- Make sure that **everyone can see** the steps involved.
- **Never** demonstrate the skill or activity incorrectly.

- Demonstrate the procedure in as **realistic** a manner as possible, using instruments and materials in a simulated clinical setting.
- Include **all steps** of the procedure in the **proper sequence** according to the approved performance standards. This includes demonstrating “nonclinical” steps such as pre- and postoperative counseling and communication with the client during surgery, use of recommended infection prevention practices, etc.
- During the demonstration, **explain to participants what is being done**, especially any difficult or hard-to-observe steps.
- **Ask questions** of participants to keep them involved.
Example: “What should I do next?” “What would happen if...?”
- **Encourage** questions and suggestions.
- **Take enough time** so that each step can be observed and understood. Remember that the objective of the demonstration is for participants to learn the skills, **not** for the clinical trainer to show her/his dexterity and speed.
- **Use equipment and instruments properly** and make sure participants clearly see how they are handled.

In addition, participants should use a clinical skills **learning guide** developed specifically for the clinical procedure to observe the clinical trainer’s performance during the initial demonstration. Doing this:

- Familiarizes the participant with the use of competency-based learning guides
- Reinforces the standard way of performing the procedure
- Communicates to participants that the clinical trainer, although very experienced, is not absolutely perfect and can accept constructive feedback on her/his performance

As the role model the participants will follow, the clinical trainer must practice what s/he **demonstrates** (i.e., the approved **standard method** as detailed in the learning guide). Therefore, it is essential that the clinical trainer use the standard method. During the demonstration, the clinical trainer also should provide supportive behavior and cordial, effective communication with **the client** and **staff** to reinforce the desired outcome.

TEACHING CLINICAL DECISION-MAKING

Clinical decision-making is the systematic process by which skilled providers make judgments regarding a patient's condition, diagnosis, and treatment. Despite the importance of sound clinical decision-making to the provision of high-quality services, it is not well taught in either preservice education or inservice training. There is so much basic knowledge to be acquired that it leaves little time for complex skills such as clinical decision-making. And even when there is enough time, decision-making is a difficult skill to teach and learn.

Until recently, very little was known about how decisions are made. For experienced providers, decision-making is an intuitive process based on knowledge and experience. Many of the steps necessary to arrive at a decision can be completed rapidly and unconsciously. Such providers are unable to explain how they make decisions, which in turn makes it difficult to teach this skill to others. Nor is it easy for learners to identify how a decision is made when simply observing other providers in action. Consequently, they have nothing to model for developing their own skill.

It is now known, however, that there is a process to clinical decision-making that can be broken down into a series of steps that help the provider to gather the information needed to form accurate judgments, begin appropriate care, and evaluate the effectiveness of that care. There are a number of different ways to name these steps, but they describe the same process. Two such approaches are illustrated below.

- **Assessment**, or Gathering information
- **Diagnosis**, or Interpreting the information
- **Planning**, or Developing the care plan
- **Intervention**, or Implementing the care plan
- **Evaluation**, or Evaluating the care plan

An important strategy in teaching clinical decision-making is to be sure that learners are aware of this step-by-step process and what occurs in each step. They also must understand that, although there is a sequence of steps for clinical decision-making, movement through the steps is rarely linear or sequential. Rather, it is an ongoing, circular process, in which the provider moves back and forth between the steps as the clinical situation changes and different needs or problems emerge.

Learners should be introduced to the steps in clinical decision-making early in their education. After that, these steps should receive continual emphasis and be used in a variety of situations. Throughout the

curriculum, learners should be given opportunities and appropriate situations in which to apply these steps and practice their decision-making skills. Whether they are actively practicing their own skills or observing more experienced providers, learners should focus on understanding the reasoning and judgment that are the basis for each step in the process. **How** a decision is made is as important as what decision is made. Explaining how a decision is made usually requires the active involvement of the teacher because the **process** of decision-making is not easy to observe or identify.

Another key strategy in teaching clinical decision-making is to provide as much experience and practice in decision-making as possible. This experience, together with clinical knowledge, is a key component of successful decision-making. Teachers should:

- Expose learners to as many and as wide a **variety of patients** as possible.
- Put learners in the **clinical setting** as early as possible and provide careful guidance as they gain their experience.
- Give learners as much **structured independence** as possible; they must be given the opportunity and time to draw their own conclusions and consider their own decisions.
- Provide learners with a forum, for example, case reviews or clinical conferences, for **comparing their decisions** with the decisions made by more experienced providers.

It is important that the teacher discuss the decision-making process with each learner, and that learners share their experiences with one another. By sharing experiences, learners get that many more cases or approaches to the same case to “file away” for future use, even though they may not have been directly involved in the cases themselves.

Finally, the teacher should give learners feedback on how the clinical decision-making process was applied in a given situation. This will strengthen future performance more effectively than focusing on whether or not the “correct answer” was identified. In fact, a wrong answer for the right reason should receive more positive feedback than a right answer for the wrong reason.

Often, it is not possible to give learners experience with all the types of situations they will encounter as independent practitioners. Their “memory files” of experience can nevertheless be built up in other ways. Extensive use of case studies, role plays, and simulations, in which specific clinical situations are acted out, can contribute significantly to learners’ experience. For example, true shoulder dystocia during childbirth is uncommon, but repeated drilling or

practice on models of the corrective maneuvers for shoulder dystocia will help learners respond to the emergency when it happens.

Tools for teaching clinical decision-making are presented throughout this learning resource package. The case studies and clinical simulations have been designed to facilitate the teaching of decision-making by reinforcing the steps involved in the process. The partograph exercises are also effective tools for decision-making. Their purpose is not simply to help learners plot data on the partograph, but rather to use those data for identifying and responding to problems as soon as, or even before, they occur. The tools alone, however, will not effectively teach clinical decision-making. The teacher must take an active role in discussing, questioning, explaining, and challenging the learners about **how** decisions are being made each time one of these tools is used. And this interaction must continue as the learners move into the clinical area and work with patients.

Clinical decision-making is still a difficult skill to teach. But by beginning early in the curriculum and continually providing practice opportunities and guidance—whether by using the tools included in this learning resource package or through experience with patients—teachers will help learners more fully understand the decision-making process and develop their decision-making skills. As a result, the quality of care received by patients will be improved.

MANAGING CLINICAL PRACTICE

Getting the most out of clinical practice requires that the trainer be well acquainted with the clinical practice sites. Being familiar with the health care facility before training begins allows the trainer to develop a relationship with the staff, overcome any inadequacies in the situation, and prepare for the best possible learning experience for participants. Even the best planning, however, is not always enough to ensure a successful clinical practice experience. In the classroom, the trainer is able to control the schedule and activities to a large extent; whereas in the clinic, the trainer must always be alert to unplanned learning opportunities that may arise at any time, and be ready to modify the schedule accordingly.

PERFORMING CLINICAL PROCEDURES WITH CLIENTS

The final stage of clinical skill development involves practicing procedures with clients. Anatomic models, no matter how realistic, cannot substitute entirely for the reality of performing the procedure with a living, breathing, feeling, and reacting human being. The **disadvantages** of using real clients during clinical skills training are obvious. Clients may be subjected to increased discomfort or even increased risk of complications when procedures are performed by unskilled clinicians. Therefore, when possible and appropriate, participants should be allowed to work with clients only after they have **demonstrated skill competency** and some degree of **skill proficiency** on an anatomic model or in a simulated situation.

The **rights of clients** should be considered at all times during a clinical training course. The following practices will help ensure that clients' rights are routinely protected during clinical training.

- The right to **bodily privacy** must be respected whenever a client is undergoing a physical examination or procedure.
- The **confidentiality** of any client information obtained during counseling, history taking, physical examinations, or procedures must be strictly observed. Clients should be reassured of this confidentiality. Confidentiality can be difficult to maintain when specific cases are used in learning exercises such as case studies and clinical meetings. Such discussions always should take place in a private area where other staff and clients cannot overhear and should be conducted without reference to the client by name.

- When receiving counseling, undergoing a physical examination, or receiving maternal and neonatal health services, **the client should be informed about the role of each person involved** (e.g., clinical trainers, individuals undergoing training, support staff, researchers).
- The **client’s permission should be obtained** before having a clinician-in-training observe, assist with, or perform any procedures. Understanding the right to refuse care from a clinician-in-training is important for every client. Furthermore, care should not be rescheduled or denied if the client does not permit a clinician-in-training to be present or provide services. In such cases, the clinical trainer or other staff member should perform the procedure.
- The **clinical trainer should be present during any client contact** in a training situation and the client should be made aware of the trainer’s role. Furthermore, the clinical trainer should be ready to intervene if the client’s safety is in jeopardy or if the client is experiencing severe discomfort.
- The **trainer must be careful how coaching and feedback are given** during practice with clients. Corrective feedback in the presence of a client should be limited to errors that could harm or cause discomfort to the client. Excessive negative feedback can create anxiety for both the client and the clinician-in-training.
- **Clients should be chosen carefully** to ensure that they are appropriate for clinical training purposes. For example, participants should **not** practice with “difficult” clients until they are proficient in performing the procedure.

CREATING OPPORTUNITIES FOR LEARNING

Planning for Learning

The clinical trainer should **develop a plan for each day spent in the health care facility**. The plan will provide a daily focus that is consistent with the learning objectives and help to ensure that all required skills will be adequately addressed. When preparing the plan, the trainer should consider the following points:

- Clinical practice should progress from **basic to more complex skills**. This not only helps ensure the safety and quality of care provided by participants, but also allows them to gain self-confidence as they demonstrate competency in the basic skills.
- **There may be more participants than can be accommodated** comfortably in one area of the health care facility at the same time. Generally, three or four participants are the most that a specific area of a facility can absorb without affecting service delivery. If there are more, the trainer should plan a rotation system that allows each participant to have equal time and opportunity in each clinical area.

- Some clinical experiences, such as **obstetrical emergencies (e.g., eclampsia, postpartum haemorrhage, obstructed labor), cannot be planned or predicted**. The trainer must be alert to identify appropriate clinical situations and distribute them equally among the participants. Before each day's practice, the trainer should ask the staff to notify her/him of any clients that may be of particular interest, so that participants can be assigned to work with them.
- In addition to daily practice of specific clinical skills, the **trainer's plan should include other areas of focus** such as infection prevention, facility logistics, or client flow. Although these topics may not be directly assessed with a checklist or other competency-based assessment tool, they play an important role in the provision of high-quality maternal and neonatal health services. To make sure that participants give adequate attention to these topics, the trainer should design and develop activities that address each one, such as:
 - Observing the infection prevention practices used in the facility. Which recommended practices are being used, and which are not? Are they being used consistently and correctly? Why or why not?
 - Reviewing facility records for the past several months to identify the types of obstetrical clients seen. Additional information could be obtained, such as the most common complaints and, in individual cases, course of labor (partograph review), progression of a specific condition, treatment provided, response to treatment, etc.
 - Taking an inventory of the supplies, equipment, and drugs available in the service provision area to ensure rapid access when needed.
- Inevitably there will be **times when there are few or no clients in the facility**. The trainer should have ready additional activities, such as those described above, for the participants. Case studies and role plays also are very useful at such times. **Even without clients, learning must continue**. Taking extended breaks or leaving the clinical site early is not an acceptable option.

In the Health Care Facility

As has been mentioned, planning alone is not sufficient to guarantee a successful clinical practice. There are several key strategies that a clinical trainer can use in the health care facility to increase the likelihood of success.

- The trainer must **actively monitor** the skills each participant is able to practice, and with what frequency, so that each participant has adequate opportunities to develop competency. A participant who demonstrates competency in performing a caesarean section

operation or in administering spinal anaesthesia should not be assigned additional patients requiring this operation or procedure until other participants have had an opportunity to develop such competency.

- It is essential that the trainer **be flexible and constantly alert** to learning opportunities as they arise. This requires knowing about the health care facility—how it is set up and functions, the client population, etc.—as well as having a good working relationship with the staff. The trainer will need to rely on the staff's cooperation in notifying her/him of unique or unusual clients and allowing participants to provide services to these clients. This relationship is most easily established beforehand, during site preparation and other visits made by the trainer.
- The **participants also should be encouraged to watch** for such learning opportunities. The trainer may then decide which, and how many, of the participants will be assigned to a particular client. The trainer and participants should remember that clinical experiences need to be shared equally. Therefore, the participant who identifies a case may not be assigned to it if this participant has had a similar case before. It is not appropriate to subject the client to a procedure multiple times simply so that all participants can practice a skill.
- To take advantage of opportunities as they occur may require that the trainer **modify the plan for that day and subsequent days**, but with as little disruption as possible to the provision of services. Participants should be notified of any changes as soon as possible so that they can be well prepared for each clinical day.
- Rarely will all participants have the opportunity to work with all types of clients. The clinical trainer will need to **supplement, with case studies and role plays, the work done with clients**. The trainer should rapidly identify important but rare events or conditions, such as severe pre-eclampsia, and prepare activities in advance. Actual cases seen in the health care facility may also serve as the basis for such activities. These can then be used during clinical sessions to expand the participants' range of experiences.

CONDUCTING PRE- AND POST-CLINICAL PRACTICE MEETINGS

Although every health care facility will not have a meeting room, the clinical trainer must make every effort to find a space that:

- Allows **free discussion**, small group work, and practice on models
- Is **away from the client care area** if possible, so as to not interfere with efficient client care or other staff duties

Pre-Clinical Practice Meetings

The trainer and participants should meet at the beginning of each clinical practice session. The meeting should be brief. Items to be covered include:

- The learning objectives for that day
- Any scheduling changes that may be needed
- Participants' roles and responsibilities for that day, including the work assignments and rotation schedule if applicable
- Special assignments to be completed that day
- The topic for the post-clinical practice meeting, so that the participants can take special note of anything happening during the day that would contribute to the discussion
- Questions related to that day's activities or from previous days if they can be answered concisely; if not, they should be deferred until the post-clinical practice meeting

Post-Clinical Practice Meetings

The clinical trainer should end each clinical day with a meeting to review the day's events and build on them as learning experiences. A minimum of 1 hour is recommended. These meetings are used to:

- Review the day's learning objectives and assess progress toward their completion
- Present cases seen that day, particularly those that were interesting, unusual or difficult
- Respond to clinical questions concerning situations and clients in the health care facility or information in the reference manual
- Plan for the next clinical session, making changes in the schedule as necessary
- Conduct additional practice with models if needed
- Review and discuss case studies, role plays, or assignments that have been prepared in advance by the participants. These activities should complement the sessions conducted during the classroom portion of the course, especially when classroom time is limited and clinical experience is necessary to gain a better understanding of the issues to be discussed. Topics for case studies, role plays, and assignments include:
 - Quality of care
 - Clinical services provided
 - Preventive care measures
 - Medical barriers to providing high-quality services
 - Recommended follow-up

THE TRAINER AS SUPERVISOR

In the role of supervisor, the trainer must monitor participant activities in the health care facility so that:

- Each participant receives appropriate and adequate opportunities for skill practice,
- Participants do not disrupt the efficient provision of services within the facility or interfere with staff and their duties, and
- The care provided by each participant does not harm clients or place them in an unsafe situation.

The trainer must always be with participants when they are working with clients, especially when they are performing clinical procedures. Trainers may have more than one or two participants to supervise. Because the trainer cannot be with all of them at the same time, other methods of supervision must be used.

- Participants must understand what they can do independently and what requires trainer supervision, so that they can keep busy when the trainer is involved with another participant. Participants should be made responsible for ensuring that they are supervised when necessary. The trainer, however, still holds the ultimate responsibility.
- Additional activities that require no direct supervision will give participants the opportunity to be actively engaged in learning when they are not with clients.
- Clinical staff also can act as supervisors if the trainer is confident of their clinical skills and ability to provide appropriate feedback. The possibility of having clinical staff supervise participants is another reason why the trainer should get to know the staff before the training begins. During clinical site preparation, the trainer can observe the skills of the staff members, and verify that they are competent, if not proficient, service providers. The trainer may also have the opportunity to assess their coaching skills. There may even be time to work with staff members to improve their skills so that they can serve as role models and support participant learning.
- The more participants there are in the facility, the more the trainer relies upon the staff to act also as trainers. Nevertheless, the ultimate responsibility for each participant, including that of final assessment of skill competency, is the trainer's. For this reason, if multiple clinical sites are used during a course, a trainer must be assigned to each site.
- Because clinical staff usually is not involved in the classroom portion of a course, they do not have an opportunity to get to know the participants and their abilities before they arrive at the facility. Therefore, it is a good idea to share such information with the

clinical staff whenever they will have to take over a large part of the participant supervision. Clinical staff should also be encouraged to do an initial assessment of participants' skills before allowing them to work with clients so that they can feel confident that the participants are well prepared.

- Clinical staff should also be aware of the feedback the trainer would like to receive from them about participants.
 - Will it be oral, written, or both? If written feedback is needed, the trainer should design an instrument or form to guide the clinical staff. The trainer should furnish a sufficient number of copies of the form and instruct the staff in its use. The trainer should develop a form that staff members can complete quickly and easily.
 - How frequently will feedback be provided? Daily? Weekly? Only at the end of training?
 - Should both positive and corrective feedback be provided?
 - Are there appropriate administrative channels through which the feedback should be transmitted? In some clinics, for example, staff members provide their feedback to the individual in charge of the health care facility who then prepares a report for the trainer.
- When designing the feedback system, the trainer should keep in mind the time required to prepare and provide feedback. This will be extra work for the clinical staff, who already have a very busy schedule. It is best to keep the system as simple and easy to use as possible.

THE TRAINER AS COACH

One of the most difficult tasks for the trainer, and one with which even experienced trainers struggle, is to be a good coach and provide feedback in the clinical setting. No matter how comfortable a trainer may be in giving feedback in the classroom or while working with models, the situation changes in the facility. The clients, staff, and other participants are nearby and the emergency services need to keep running smoothly and efficiently. The trainer often feels pressured to keep things moving because other clients need to be seen and the trainer needs to be available to all the participants. Spending “too much time” with any one client or participant has an impact on everyone.

Feedback Sessions

The feedback sessions before and after practice are often skipped in an effort to save time. These sessions, however, are very important for the continued development of the participant's psycho-motor or decision-

making skills. Without adequate feedback and coaching, the participant may miss an important learning opportunity and take longer to achieve competency. Keep in mind that by this time the participant has already demonstrated competency on a model and may not need extensive feedback. To minimize disruption of services, the pre- and post-practice feedback sessions can take place in just a few minutes in a location away from the client care areas.

The structure of the feedback session is essentially the same regardless of whether the session takes place before or after practice, and whether it is for a participant's performance with models or with clients.

- The participant should first identify personal strengths and the areas where improvement is needed.
- Next, the trainer should provide specific, descriptive feedback that includes suggestions of not only what, but also how, to improve.
- Finally, the participant and the trainer should agree on what will be the focus of the practice session, including how they will interact while they are with the client. For example, they may agree that if the trainer places a hand on the participant's shoulder, it is a signal to stop and wait for further instructions.

The feedback session before practice should be given before the trainer and participant enter the room to work with the client. The feedback session after practice can be delayed until the client's care has been completed or the client is in stable condition so that continuous care is no longer needed. The trainer should try not to delay feedback any longer than necessary. Feedback is always more effective when given as soon after care as possible. This will also allow the participant to use the feedback with the next client for whom services are provided, if appropriate.

Feedback during a Procedure

Be sure the client knows that the participant, although already a service provider, is also a learner. Reassure the client that the participant has had extensive practice and mastered the skill on models. The client should expect to hear the trainer talk to the participant and understand that it does not mean that something is wrong. Finally, the client should clearly understand that the trainer is a proficient service provider and is there to ensure that the procedure is completed safely and without delay.

Positive Feedback

Positive feedback is often easy to give and can be provided in the presence of the client. Trainers often think that hearing feedback, even positive feedback, will disturb the client. Many clients, however, find

it comforting to hear the service provider being given positive feedback.

- Keep the feedback restrained and low-key; overly exuberant praise can be as worrisome to the client as hearing negative comments. Too much praise may cause the client to wonder, “What is being hidden?” “Why is it so surprising that this person is doing a good job?”
- Positive feedback can be conveyed by facial expression and tone of voice rather than words, and still be highly effective.

At the same time, the **absence** of feedback of any kind can be disturbing to the participant. By this phase of skill development the participant is expected to do a good job even with the first client, and is accustomed to hearing positive comments. Therefore, in order to maintain the participant’s confidence, it is still important to give positive feedback.

Corrective Feedback

Corrective feedback is difficult to give under any circumstances, but particularly when a client is present. It is important to keep such feedback low-key and restrained. There are a number of techniques that will make it easier.

- Often a look or hand gesture (e.g., a touch on the shoulder) can be as effective as words and less worrisome to the client.
- Simple suggestions to facilitate the procedure can be made in a quiet, direct manner. Do not go into lengthy explanations of why you are making the suggestion or offering an observation—save that for the post-practice feedback session.
- To help a participant avoid making a mistake, the trainer can calmly ask a simple, straightforward question about the procedure itself. If a step in a procedure is about to be missed, for example, asking the participant to name the next step **before** doing anything further could help avoid an error. This is **not** the time to ask hypothetical questions about potential side effects and complications, as this may distract the participant and alarm the client.
- Sometimes, even though they have had extensive practice on models, participants make mistakes that can potentially harm the client. In these instances, the trainer must be prepared to step in and take over the procedure at a moment’s notice. This should be done calmly and with complete control to avoid unnecessarily alarming the client.

SECTION FOUR: SUPPLEMENTAL INFORMATION

The Multiload Cu375: Frequently Asked Questions	1
Anatomy of Multiload Cu375 Assembly and Packaging.....	3
Instructions for Inserting and Removing the Multiload Cu375	
Inserting Multiload	5
Removing Multiload.....	7
Learning Guide for IUD Clinical Skills (Adapted for the Multiload Cu375)	9
Checklist for IUD Counseling and Clinical Skills	
(Adapted for the Multiload Cu375)	15
MIRENA®: Frequently Asked Questions	19

THE MULTILOAD CU375: FREQUENTLY ASKED QUESTIONS

1. What is the Multiload Cu375?

The Multiload Cu375 is a copper-releasing intrauterine contraceptive device (IUD) that is effective for 5 years. It is widely used and well known for its unique design, as well as its effectiveness, ease of insertion, wide margin of safety, acceptability to clients, and low cost.

2. What does “Multiload” mean?

The Multiload IUD was originally designed so that the same basic “skeleton” (stem and arms) could be loaded with different amounts of copper or hormones in subsequent models.

3. How long has the Multiload been around?

Designed by Willem van Os, the Multiload Cu250 was inserted for the first time in The Netherlands in 1972. Since then, several new models have been developed. The Multiload 375A, which has a higher copper load than the ML Cu250, is among the most widely used IUDs in the world today.

4. What does “Cu375” refer to?

“Cu” means Copper, and “375” refers to copper surface area in mm². Whereas the Multiload Cu375 has a copper surface area of 375 mm², the Multiload Cu250 has a copper surface area of 250 mm².

5. Why is the Multiload shaped as it is?

The plastic arms of the Multiload have little “spurs” on them, providing a fundal-hugging effect that helps to ensure that the IUD remains as high up in the fundus as possible. The arms are also curved to help protect against puncturing the uterine wall.

6. What are the main differences between the Multiload Cu375 and the Copper T 380A?

Lifespan of contraceptive efficacy: Multiload Cu375 is effective for 5 years; Copper T 380A is effective for at least 12 years.

Loading: Multiload is preloaded (does not require loading before insertion), whereas the Copper T is loaded in its sterile package before insertion.

Insertion technique: Multiload is released into the uterus by withdrawing the insertion tube. The Copper T, on the other hand, is released from the insertion tube by pushing the plunger rod before the insertion tube is withdrawn.

Removal technique: Removal of Multiload requires the use of a tenaculum, whereas removal of the Copper T generally does not.

Level of discomfort upon insertion and removal: Insertion and removal may be slightly more uncomfortable for the Multiload user than for the Copper T user.

7. What are the main similarities between the Multiload Cu375 and the Copper T 380A?

Mechanism of action: As copper-bearing IUDs, the Copper T 380A and Multiload Cu375 act primarily by preventing fertilization.

Contraceptive efficacy: Among the copper-bearing IUDs, the Copper T 380A and Multiload Cu375 have the largest surface areas of copper and are the most effective, with a failure rate of 0.6 to 0.8 per 100 women per year (WHO 2000).

Applicability of World Health Organization (WHO) eligibility criteria: Considerations, precautions, and contraindications based on these criteria are essentially the same for all copper-bearing IUDs, including the Copper T 380A and Multiload Cu375.

Menstrual problems: Prevalence of menstrual problems among Multiload versus Copper T users is comparable.

Other problems: Prevalence of expulsion, ectopic pregnancy, and uterine perforation among Multiload versus Copper T users is low but comparable.

ANATOMY OF MULTILOAD CU375 ASSEMBLY AND PACKAGING

This handout presents key information on the assembly (parts used in insertion procedure) and packaging of the Multiload Cu375. A working knowledge of the basic structure and main parts of the IUD's assembly and packaging—as well as the associated terminology—is critical to the provision of quality IUD services.

Key parts of the Multiload Cu375 are clearly identified in Figure S-1, and terminology is defined as follows:

- The **insertion tube** is used to guide the IUD through the cervical canal and into the uterus.
- The **cervical guard** helps to ensure that the IUD will be inserted as high in the fundus as possible without perforating the uterine wall.
- The **measurement insert** is used in setting the cervical guard to the measurement obtained when sounding the uterus.

Figure S-1. Key parts of the Multiload Cu375

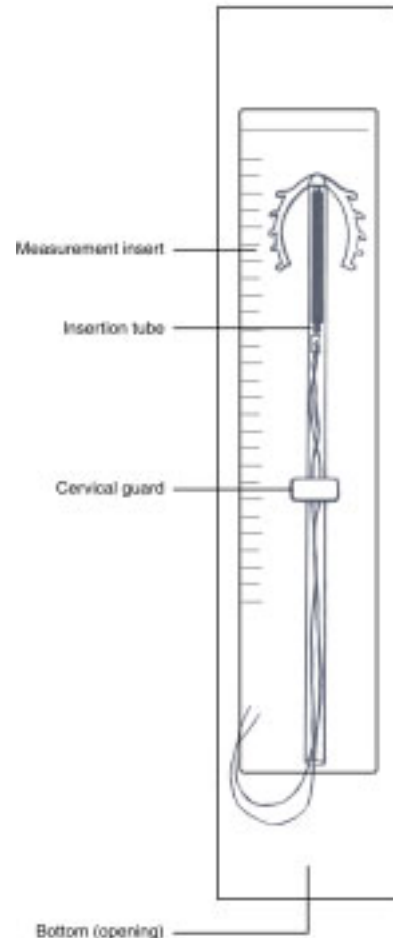

INSTRUCTIONS FOR INSERTING AND REMOVING THE MULTILOAD CU375¹

INSERTING MULTILOAD

See Chapter 5 in the reference manual for steps that should happen before and after inserting Multiload. Note that the Multiload does not have to be loaded in its sterile package first (it is “preloaded”).

Using gentle, no-touch (aseptic) technique throughout, perform the following steps:

STEP 1: Put new/clean examination or high-level disinfected surgical gloves on both hands (if not already done).

STEP 2: Prepare the client:

- Give the woman a brief overview of the procedure (as shown above), encourage her to ask questions, and provide reassurance as needed.
- Remind her to let you know if she feels any pain.

STEP 3: Gently grasp the tenaculum and apply gentle traction:

Hold the loaded IUD so that the cervical guard is in the horizontal position with one hand, while grasping the tenaculum (still in place from sounding the uterus) with the other hand and gently pulling outward and downward. (This will help straighten the cervical canal for easier insertion of the IUD.)

STEP 4: Carefully insert the loaded IUD: Carefully insert the loaded IUD into the vaginal canal, and gently push it through the cervical os and into the uterine cavity at the appropriate angle (based on your assessment of the position of the uterus when sounding the uterus). **Be careful not to touch the walls of the vagina or the speculum blades with the tip of the loaded IUD.**

During insertion, the flexible arms of the Multiload will fold inward, accommodating the shape of the cervical canal (Figure S-2). The arms spring back into shape once they have passed through.

Note: Women who are having the Multiload Cu375 inserted may feel more discomfort (than those having a Copper T inserted) as the arms of the IUD pass through the cervical os, especially if they are nulliparous.

Figure S-2. Arms of Multiload Folding Inward

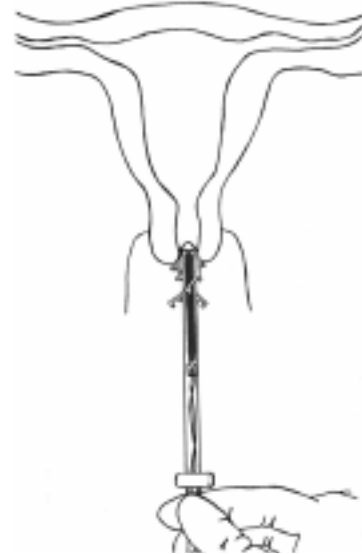

¹ Information on Multiload insertion is based in part on Organon's *Multiload Range Copper IUDs: Guidelines for Health Workers*.

Figure S-3. Advancing the Multiload

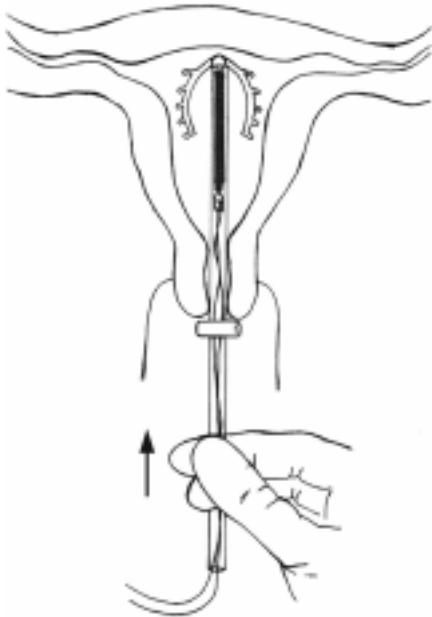
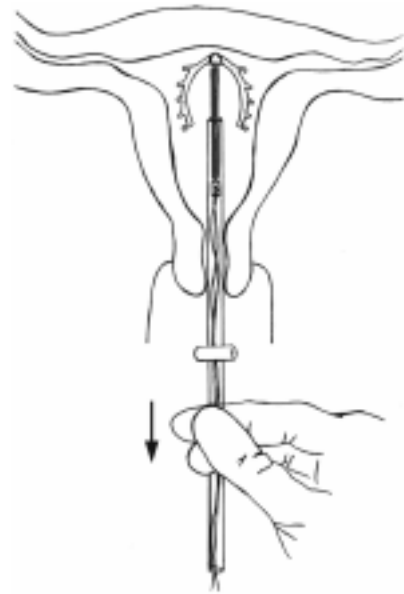

Figure S-4. Withdrawing the Inserter Tube



STEP 5: Gently advance the loaded IUD into the uterine cavity, and STOP when the cervical guard comes in contact with the cervix or slight resistance is felt (Figure S-3). Be sure that the cervical guard is still in the horizontal position.

Do **not** use force at any stage of this procedure.

STEP 6: Continuing to apply gentle downward traction to the tenaculum, remove the inserter tube from the cervical canal (Figure S-4).

Do **not** pass the loaded IUD into the uterus more than once.

Note: Sharp blades are very important. If the scissor blades are too dull to cut well, the IUD strings may become trapped in the closed blades of the scissors, and the IUD may be accidentally removed when the scissors are withdrawn.

STEP 7: Use high-level disinfected (or sterile) sharp Mayo scissors to cut the IUD strings at 3 to 4 cm:

- Partially withdraw the insertion tube from the cervical canal until the strings can be seen extending from the cervical os, and use sharp Mayo scissors to cut the strings at 3 to 4 cm from the cervical opening. (This technique ensures that the pieces of cut-off string will stay in the insertion tube for easy disposal.)
- Place the insertion tube and scissors in 0.5% chlorine solution for 10 minutes for decontamination.

STEP 8: Gently remove the tenaculum and place it in 0.5% chlorine solution for 10 minutes for decontamination.

STEP 9: Examine the woman's cervix for bleeding: If there is bleeding where the tenaculum was attached to the cervix, use high-level disinfected (or sterile) forceps to place a cotton (or gauze) swab on the affected tissue, and apply gentle pressure for 30 to 60 seconds.

STEP 10: Gently remove the speculum and place it in 0.5% chlorine solution for 10 minutes for decontamination.

STEP 11: Allow the woman to rest. Advise the woman to remain on the examination table until she feels ready to get dressed. Begin performing the post-insertion steps (below) while she is resting.

Note: Women who are having the Multiload Cu375 removed may feel more discomfort (than those having a Copper T removed) as the arms of the IUD pass through the cervical os, especially if they are nulliparous.

REMOVING MULTILOAD

See Chapter 5 in the reference manual for steps that should happen before and after removal of Multiload.

STEP 1: Prepare the client:

- Give the woman a brief overview of the procedure, encourage her to ask questions, and provide reassurance as needed.
- Remind her to let you know if she feels any pain.

STEP 2: Put new/clean examination or high-level disinfected surgical gloves on both hands.

STEP 3: Insert a high-level disinfected (or sterile) speculum and visualize the cervix and the IUD strings.

→ If the strings can not be seen, manage as Missing Strings (reference manual, page 6-11).

STEP 4: Cleanse the cervix and vagina with an appropriate antiseptic: Thoroughly apply an appropriate antiseptic (e.g., povidone iodine or chlohexidine) two or more times to the cervix (wiping from inside the os outward) and vagina. If povidone iodine is used, ensure that the woman is not allergic to iodine and wait 2 minutes for the solution to act.

STEP 5: Apply a HLD (or sterile) tenaculum to the cervix to straighten out the uterine axis. This will help prevent the IUD arms from breaking as they pass through the os.

STEP 6: Alert the woman immediately before you remove the IUD:

- Ask her to take slow, deep breaths and relax.
- Inform her that she may feel some discomfort and cramping, which is normal.

Do **not** use force at any stage of this procedure.

STEP 7: Grasp the IUD strings and apply gentle traction:

- Grasp the strings of the IUD with a high-level disinfected (or sterile) narrow forceps. **With the Multiload, it is important to grasp the strings as close to the cervical os as possible.**
- Apply steady but gentle traction, gently pulling the strings toward you with the forceps). (The device can usually be removed without difficulty.)
 - If the strings break off but the IUD is visible, grasp the device with the forceps and remove it.
 - If removal is difficult, **do not use excessive force!** See Textbox 5-2 (reference manual, page 5-17) for guidance on managing this problem.

STEP 8: Gently remove the speculum, and place it in 0.5% chlorine solution for 10 minutes for decontamination.

STEP 9: Show the woman the IUD, and place it in 0.5% chlorine solution for 10 minutes for decontamination.

STEP 10: Insert a new IUD, if the woman so desires and there are no precautions to continued use.

LEARNING GUIDE FOR IUD CLINICAL SKILLS

(ADAPTED FOR THE MULTILOAD CU375)

(To be used by **Participants**)

Rate the performance of each step or task observing the following rating scale:

- 1 Needs Improvement:** Step or task not performed correctly or out of sequence (if necessary) or is omitted
- 2 Competently Performed:** Step or task performed correctly in proper sequence (if necessary) but participant does not progress from step to step efficiently
- 3 Proficiently Performed:** Step or task efficiently and precisely performed in the proper sequence (if necessary)

LEARNING GUIDE FOR IUD <i>CLINICAL SKILLS</i> (MULTILOAD CU375)					
STEP/TASK	CASES	1	2	3	4
IUD INSERTION					
Client Assessment					
1. Greet the client with kindness and respect.					
2. Determine that the client has been counseled about the IUD in general, as well about the insertion procedure.					
History					
3. Review the client's contraceptive, menstrual, and obstetric history to confirm that the IUD is an appropriate choice for the client, focusing especially on ensuring that the client is not pregnant . Ask about: <ul style="list-style-type: none"> ● Heavy, prolonged, or menstrual painful periods ● Parity/gravida ● Childbirth or abortion within the last 4 weeks; signs/symptoms of infection with either ● Possibility of pregnancy (delayed or missing period, unprotected sex since last menstrual period [LMP]) (Note: If needed, use checklist provided in Appendix B to be reasonably sure the client is not pregnant.)					
4. Review the client's pertinent (general and reproductive) medical history to confirm that the IUD is an appropriate choice for the client, focusing especially on ensuring that the client is not at high individual risk of sexually transmitted infections (STIs) . Ask about: <ul style="list-style-type: none"> ● Severe anemia ● HIV/AIDS ● Complicated valvular heart disease ● Cancer of the reproductive organs ● Trophoblastic disease ● Pelvic tuberculosis ● Unexplained vaginal bleeding ● High individual risk of STIs <ul style="list-style-type: none"> – STI within last 3 months (self or partner) – Multiple partners (self or partner) – Partner with symptoms of STI (e.g., penile discharge) ● Diagnosis of pelvic inflammatory disease (PID), gonorrhea, chlamydia, or other STIs (within last 3 months) ● Symptoms of PID, gonorrhea, chlamydia, or other STIs <ul style="list-style-type: none"> – Lower abdominal pain – Current unusual or purulent vaginal discharge 					
Physical Examination					
5. Ensure that a high-level disinfected (HLD) instrument pan (or sterile pack), supplies, and light source are available.					

LEARNING GUIDE FOR IUD <i>CLINICAL SKILLS</i> (MULTILOAD CU375)					
STEP/TASK	CASES				
6. Have the client empty her bladder and wash and rinse her perineal area if possible.					
7. Help the client onto the examination table.					
8. Tell the client what is going to be done, and ask her if she has any questions.					
9. Wash your hands thoroughly with soap and water; and dry them with clean, dry cloth or allow them to air dry.					
10. Check for signs of anemia/severe anemia .					
11. Palpate the abdomen : <ul style="list-style-type: none"> ● Check for suprapubic tenderness. ● Check for swellings, bulges, masses, or other gross-abnormalities. 					
12. Drape the client appropriately for pelvic exam.					
13. Wash your hands <u>again</u> thoroughly with soap and water; and dry them with clean, dry cloth or allow them to air dry.					
14. Open the HLD instrument pan (or sterile pack) without touching instruments.					
15. Using an HLD (or sterile) pick-up forcep, arrange the instruments and supplies on an HLD pan (or sterile tray), being very careful not to touch parts of the instruments that will go into the vagina or uterus.					
16. Put new/clean examination or HLD (or sterile) surgical gloves on both hands.					
17. Inspect the external genitalia and urethral opening: <ul style="list-style-type: none"> ● Check for ulcers, lesions, and sores. ● Check for buboes (enlarged groin nodes). ● Palpate Skene's and Bartholin's glands, checking for tenderness or discharge. 					
Note: <ul style="list-style-type: none"> ● If findings are normal (findings that do not suggest possible infection or other pelvic problems), perform the bimanual exam first and the speculum exam second. This allows you to sound the uterus and insert the IUD without having to insert the speculum twice. ● If there are potential problems (findings that suggest possible infection or other pelvic problems), perform the speculum exam first and a bimanual exam second. 					
18a. Perform a bimanual exam (see Note above): <ul style="list-style-type: none"> ● Determine the size, shape, and position of uterus. ● Check for enlargement or tenderness of the adnexa and for cervical motion tenderness. ● Check for uterine abnormalities that may interfere with proper placement of the IUD. 					
18b. Perform rectovaginal exam only if: <ul style="list-style-type: none"> ● Position or size of uterus is unclear. ● There is a possible mass behind the uterus. 					
18c. If rectovaginal exam is performed, do the following before continuing: <ul style="list-style-type: none"> ● Immerse both gloved hands in 0.5% solution. ● Remove gloves by turning inside out and dispose of them ● Put on new/clean examination or HLD (or sterile) gloves. 					
19. Perform a speculum exam (see Note above) of the vagina and cervix (by gently spreading the labia with two fingers and then inserting the HLD [or sterile] speculum, starting obliquely and then rotating it to the horizontal position): <ul style="list-style-type: none"> ● Check for purulent vaginal discharge. ● Check for ulcers, lesions, and sores. ● Check cervix for purulent cervicitis, bleeding, erosions, or narrowing of the cervical canal (stenosis). (Note: If laboratory testing is indicated and available, refer to steps at the end of learning guide.)					

LEARNING GUIDE FOR IUD <i>CLINICAL SKILLS</i> (MULTILOAD CU375)					
STEP/TASK	CASES				
Preinsertion and Insertion Steps					
1. If both bimanual and speculum exams are normal, give the client a brief overview of the insertion procedure, encourage her to ask questions, and provide reassurance if needed. Remind her to let you know if she feels any pain.					
Sounding the Uterus					
2. Gently insert the HLD (or sterile) speculum (if not already done; visualize cervix), and cleanse the cervical os and vaginal wall with an appropriate antiseptic two or more times.					
3. Gently grasp the cervix with an HLD (or sterile) tenaculum and apply gentle traction. Do not lock the tenaculum beyond the first notch, unless necessary.					
4. While gently pulling on the tenaculum, and without allowing the tip of the sound to touch the vaginal walls or the speculum blades, carefully insert the sound into the cervical os.					
5a. Gently advance the sound at the appropriate angle (based on bimanual exam).					
5b. STOP advancing the sound when a slight resistance is felt, and confirm the position of the uterus (anterior or posterior) for the IUD insertion. Do not use force at any stage of this procedure.					
6. Remove the sound. (Do not pass the sound into the uterus more than once.)					
7. Determine the depth of the uterus by noting the level of mucus or wetness on the sound.					
8. Place the sound in 0.5% chlorine solution for 10 minutes for decontamination.					
Removing Multiload from its Sterile Package (Note: The Multiload does not require loading because its vertical stem is “preloaded” in the inserter tube, and its arms are flexible enough to adapt to the shape of the cervical canal.)					
9. Prepare to remove Multiload from its sterile package: <ul style="list-style-type: none"> Place package on flat surface. Remove wrapping 1/3 of the way by lifting the transparent front sheet from the bottom end of the package 					
10. Grasp the insertion tube and the IUD string together at the lower end of the tube.					
11. Move the cervical guard to the number corresponding to the measurement obtained from sounding the uterus, using the no-touch technique.					
12. Remove loaded insertion tube from the package without touching anything that is not sterile. Make sure to hold the tube level so that the IUD does not fall out.					
Inserting Multiload					
13. Put new/clean examination or HLD (or sterile) surgical gloves on both hands (if not already done).					
14. Give the client a brief overview of the procedure, encourage her to ask questions, and provide reassurance if needed. Remind her to let you know if she feels any pain. (Note: Women who are having the Multiload Cu375 inserted may feel more discomfort [than those having a Copper T inserted] as the arms of the IUD pass through the cervical os, especially if they are nulliparous.)					
15. Hold the IUD so that cervical guard is in horizontal position. Gently grasp the tenaculum with the other hand and gently pull outward and downward.					
16a. Carefully insert the loaded IUD into the vaginal canal and gently push it through the cervical os and into uterine cavity at the appropriate angle (based on sounding).					

LEARNING GUIDE FOR IUD <i>CLINICAL SKILLS</i> (MULTILOAD CU375)					
STEP/TASK	CASES				
16b. Gently advance the loaded IUD into the uterine cavity until the cervical guard comes into contact with the cervix or slight resistance is felt. (Important: Be careful not to touch the wall of vagina or the speculum blades with the tip of the loaded IUD. Do not use force at any stage of this procedure.)					
17. Continuing to apply gentle downward traction to the tenaculum, remove the inserter tube from the cervical canal.					
18. Partially withdraw the insertion tube from the cervical canal until the string can be seen extending from the cervical os.					
19. Use HLD (or sterile) sharp Mayo scissors to cut the IUD strings to 3–4 cm length.					
20. Gently remove the tenaculum and place in 0.5% chlorine solution for 10 minutes for decontamination.					
21. Examine the cervix. If there is bleeding where the tenaculum was attached to the cervix, use HLD (or sterile) forceps to place cotton (or gauze) swab on the affected tissue, and apply gentle pressure for 30–60 seconds.					
22. Gently remove speculum and place in 0.5% chlorine solution for 10 minutes for decontamination.					
23. Ask the client if she is experiencing nausea, mild to moderate lower abdominal pain/cramping, and dizziness or fainting. If she is experiencing any of these symptoms, provide reassurance and allow her remain on the examination table until she feels better (she should stay in clinic for at least 15 to 30 minutes). Begin performing the postinsertion steps.					
Postinsertion Steps					
1. Before removing the gloves, place all used instruments in 0.5% chlorine solution for 10 minutes for decontamination. (After the client has left, wipe the examination table with 0.5% chlorine solution.)					
2. Dispose of waste materials (e.g., cotton balls) by placing in a leak-proof container (with a tight-fitting lid) or plastic bag.					
3. Immerse both gloved hands in 0.5% chlorine solution. Remove gloves by turning inside out: <ul style="list-style-type: none"> ● If disposing of gloves, place in the leak-proof container or plastic bag. ● If reusing surgical gloves (not recommended), submerge them in 0.5% chlorine solution for 10 minutes for decontamination. 					
4. Wash hands thoroughly with soap and water; and dry them with a clean, dry cloth or air dry.					
5. Provide postinsertion instructions (key messages for IUD users): <ul style="list-style-type: none"> ● Basic facts about her IUD (e.g., type, how long effective, when to replace/remove) ● No protection against STIs; need for condoms if at risk ● Possible side effects ● Warning signs (PAINS) ● Checking for possible IUD expulsion ● When to return to clinic 					
IUD REMOVAL					
Preremoval Steps					
1. Greet the woman with kindness and respect, and establish purpose of visit.					
2. Ask the woman her reason for having the IUD removed.					
3. Determine whether she will have another IUD inserted immediately, start a different method, or neither.					

LEARNING GUIDE FOR IUD <i>CLINICAL SKILLS</i> (MULTILOAD CU375)					
STEP/TASK	CASES				
4. Counsel as appropriate: <ul style="list-style-type: none"> • Ensure that she understands that there is immediate return to fertility after IUD removal. • Review the client's reproductive goals and need for STI protection • Discuss other contraceptive methods if desired. 					
5. Ensure that a high-level disinfected (HLD) instrument pan (or sterile pack), supplies, and light source are available.					
6. Open the HLD instrument pan (or sterile pack) without touching instruments. Using an HLD (or sterile) pick-up forcep, arrange the instruments and supplies on an HLD pan (or sterile tray), being very careful not to touch parts of the instruments that will go into the vagina or uterus.					
7. Have the client empty her bladder and wash and rinse her perineal area if possible.					
8. Help the client onto the examination table.					
9. Wash your hands thoroughly with soap and water; and dry them with clean, dry cloth or allow them to air dry.					
10. Put new/clean examination or HLD (or sterile) surgical gloves on both hands.					
11. Give the client a brief overview of the procedure, encourage her to ask questions, and provide reassurance as needed. Remind her to let you know if she feels any pain. (Note: Women who are having the Multiload Cu375 removed may feel more discomfort [than those having a Copper T removed] as the arms of the IUD pass through the cervical os, especially if they are nulliparous.)					
Removing Multiload					
1. Insert an HLD (or sterile) speculum to visualize the IUD strings.					
2. Cleanse the cervix (especially the os) and vagina with an appropriate antiseptic two or more times.					
3. Apply a HLD (or sterile) tenaculum to the cervix to straighten out the uterine axis. This will help prevent the IUD arms from breaking as they pass through the os.					
4. Alert the client immediately before you remove the IUD. Ask her to take slow, deep breaths and inform her that she may feel some discomfort and cramping, which is normal.					
5. Grasp the IUD strings close to the cervix with an HLD (or sterile) hemostat or other narrow forceps. With the Multiload, it is important to grasp the strings as close to the cervical os as possible.					
6. Apply steady but gentle traction, pulling the strings toward you, to remove the IUD. Do not use excessive force.					
7. Show the IUD to client.					
8. Place the IUD in 0.5% chlorine solution for 10 minutes for decontamination.					
9. If the woman is having a new IUD inserted, insert it now if appropriate. If she is not having a new IUD inserted, gently remove the speculum and place it in 0.5% chlorine solution for 10 minutes for decontamination.					
10. Ask the client if she is experiencing nausea, mild to moderate lower abdominal pain/cramping, and dizziness or fainting. If she is experiencing any of these symptoms, provide reassurance and allow her remain on the examination table until she feels better (she should stay in clinic for at least 15 to 30 minutes).					

LEARNING GUIDE FOR IUD <i>CLINICAL SKILLS</i> (MULTILOAD CU375)					
STEP/TASK	CASES				
Postremoval Steps					
1. Before removing the gloves, place all used instruments in 0.5% chlorine solution for 10 minutes for decontamination. (After the client has left, wipe the examination table with 0.5% chlorine solution.)					
2. Dispose of waste materials (e.g., cotton balls) by placing in a leak-proof container (with a tight-fitting lid) or plastic bag.					
3. Immerse both gloved hands in 0.5% chlorine solution. Remove gloves by turning inside out: <ul style="list-style-type: none"> • If disposing of gloves, place in the leak-proof container or plastic bag. • If reusing surgical gloves (not recommended), submerge them in 0.5% chlorine solution for 10 minutes for decontamination. 					
4. Wash hands thoroughly with soap and water; and dry them with a clean, dry cloth or air dry.					
5. If the woman has had a new IUD inserted, review key messages for IUD users. [If the woman is starting a different method, provide the information she needs to use it safely and effectively (and a back-up method, if needed).]					
*Laboratory Testing (if available and if indicated based on assessment)					
1. Remove speculum after taking samples of vaginal and cervical discharge.					
2. Immerse both gloved hands in 0.5% solution. Remove gloves by turning inside out. <ul style="list-style-type: none"> • If disposing of gloves, place in leakproof container or plastic bag. • If reusing surgical gloves (not recommended), submerge in 0.5% chlorine solution for 10 minutes for decontamination. 					
3. Prepare for saline and KOH wet mounts and Gram staining.					
4. Identify on the wet mounts: <ul style="list-style-type: none"> • Vaginal epithelial cells • Trichomoniasis (if present) • Monilia (if present) • Clue cells (if present) 					
5. Identify on the Gram stain: <ul style="list-style-type: none"> • WBC (polymorphonuclear white cells) (if present) • Gram-negative intracellular diplococci (GNID) (if present) • Clue cells (if present) 					
6. When testing is done, wash hands thoroughly with soap and water; and dry them with clean, dry cloth or air-dry.					
7. Treat any conditions identified according to national guidelines/local protocols (refer, if needed).					

CHECKLIST FOR IUD COUNSELING AND CLINICAL SKILLS

(ADAPTED FOR THE MULTILOAD CU375)

(To be completed by the Trainers)

Place a “✓” in case box of step/task is performed satisfactorily, an “X” if it is not performed satisfactorily, or **N/O** if not observed.

Satisfactory: Performs the step or task according to the standard procedure or guidelines

Unsatisfactory: Unable to perform the step or task according to the standard procedure or guidelines

Not Observed: Step, task or skill not performed by participant during evaluation by trainer

Participant _____ Course Dates _____

CHECKLIST FOR IUD COUNSELING AND CLINICAL SKILLS (MULTILOAD CU375)					
STEP/TASK	CASES				
METHOD-SPECIFIC COUNSELING					
1. Once the woman has chosen to use the IUD, assess her knowledge of the method.					
2. Ensure that she knows that menstrual changes are a common side effect among IUD users, and that the IUD does not protect against STIs.					
3. Describe the medical assessment required before IUD insertion, as well as the procedures for IUD insertion and removal.					
4. Encourage her to ask questions. Provide additional information and reassurance as needed.					
SKILL/ACTIVITY PERFORMED SATISFACTORILY					
IUD INSERTION					
Client Assessment (Use Appendix B to confirm that the woman is eligible for IUD use.)					
1. Review the client’s medical and reproductive history.					
2. Ensure that equipment and supplies are available and ready to use.					
3. Have the client empty her bladder and wash her perineal area.					
4. Help the client onto the examination table.					
5. Tell the client what is going to be done, and ask her if she has any questions.					
6. Wash hands thoroughly and dry them.					
7. Palpate the abdomen .					
8. Wash hands thoroughly and dry them <u>again</u> .					
9. Put clean or HLD gloves on both hands.					
10. Inspect the external genitalia.					
Note:					
<ul style="list-style-type: none"> ● If findings are normal, perform the bimanual exam first and the speculum exam second. ● If there are potential problems, perform the speculum exam first and a bimanual exam second. 					
11a. Perform a bimanual exam (see Note above)					
11b. Perform rectovaginal exam only if indicated.					
11c. If rectovaginal exam is performed, change gloves before continuing.					

CHECKLIST FOR IUD COUNSELING AND CLINICAL SKILLS (MULTILOAD CU375)					
STEP/TASK	CASES				
12. Perform a speculum exam (see Note above). (Note: If laboratory testing is indicated and available, take samples now.)					
SKILL/ACTIVITY PERFORMED SATISFACTORILY					
Preinsertion and Insertion Steps (Using aseptic, “no touch” technique throughout)					
1. Provide an overview of the insertion procedure. Remind her to let you know if she feels any pain.					
2. Gently insert the HLD (or sterile) speculum to visualize the cervix (if not already done), and cleanse the cervical os and vaginal wall with antiseptic.					
3. Gently grasp the cervix with an HLD (or sterile) tenaculum and apply gentle traction.					
4. Insert the HLD (or sterile) sound using the “no touch” technique.					
5. Grasp the insertion tube and the IUD string together at the lower end of the tube.					
6. Move the cervical guard to the measurement of the uterus.					
7. Gently advance the loaded IUD into the uterine cavity until the cervical guard touches cervix or a slight resistance is felt					
8. Continuing to apply gentle downward traction to the tenaculum, remove the inserter tube from the cervical canal.					
9. Partially withdraw the insertion tube from the cervical canal until the string can be seen extending from the cervical os.					
10. Use HLD (or sterile) sharp Mayo scissors to cut the IUD strings to 3–4 cm length.					
11. Gently remove the tenaculum and speculum and place in 0.5% chlorine solution for 10 minutes for decontamination..					
12. Examine the cervix for bleeding.					
13. Ask how the client is feeling and begin performing the postinsertion steps.					
SKILL/ACTIVITY PERFORMED SATISFACTORILY					
Postinsertion Steps					
1. Before removing the gloves, place all used instruments in 0.5% chlorine solution for 10 minutes for decontamination.					
2. Properly dispose of waste materials.					
3. Process gloves according to recommended IP practices.					
4. Wash hands thoroughly and dry them.					
5. Provide postinsertion instructions (key messages for IUD users): <ul style="list-style-type: none"> ● Basic facts about her IUD (e.g., type, how long effective, when to replace/remove) ● No protection against STIs; need for condoms if at risk ● Possible side effects ● Warning signs (PAINS) ● Checking for possible IUD expulsion ● When to return to clinic 					
SKILL/ACTIVITY PERFORMED SATISFACTORILY					
IUD REMOVAL					
Preremoval Steps					
1. Ask the woman her reason for having the IUD removed.					
2. Determine whether she will have another IUD inserted immediately, start a different method, or neither.					

CHECKLIST FOR IUD COUNSELING AND CLINICAL SKILLS (MULTILOAD CU375)				
STEP/TASK	CASES			
3. Review the client's reproductive goals and need for STI protection, and counsel as appropriate.				
4. Ensure that equipment and supplies are available and ready to use.				
5. Have the client empty her bladder and wash her perineal area.				
6. Help the client onto the examination table.				
7. Wash hands thoroughly and dry them.				
8. Put new or HLD gloves on both hands.				
SKILL/ACTIVITY PERFORMED SATISFACTORILY				
Removing the IUD				
1. Provide an overview of the insertion procedure. Remind her to let you know if she feels any pain.				
2. Gently insert the HLD (or sterile) speculum to visualize the strings, and cleanse the cervical os and vaginal wall with antiseptic.				
3. Apply an HLD (or sterile) tenaculum to the cervix to straighten out the uterine axis.				
4. Alert the client immediately before you remove the IUD.				
5. Grasp the IUD strings close to the cervix with an HLD (or sterile) hemostat or other narrow forceps. With the Multiload, it is important to grasp the strings as close to the cervical os as possible.				
6. Show the IUD to client.				
7. Place the IUD in 0.5% chlorine solution for 10 minutes for decontamination.				
8. If the woman is having a new IUD inserted, insert it now if appropriate. [If she is not having a new IUD inserted, gently remove the speculum and place it in 0.5% chlorine solution for 10 minutes for decontamination.]				
9. Ask how the client is feeling and begin performing the postremoval steps.				
SKILL/ACTIVITY PERFORMED SATISFACTORILY				
Postremoval Steps				
1. Before removing the gloves, place all used instruments and the IUD in 0.5% chlorine solution for 10 minutes for decontamination.				
2. Properly dispose of waste materials.				
3. Process gloves according to recommended IP practices.				
4. Wash hands thoroughly and dry them.				
5. If the woman has had a new IUD inserted, review key messages for IUD users. [If the woman is starting a different method, provide the information she needs to use it safely and effectively (and a back-up method, if needed).]				
SKILL/ACTIVITY PERFORMED SATISFACTORILY				

PARTICIPANT IS **QUALIFIED** **NOT QUALIFIED** TO DELIVER IUD SERVICES, BASED ON THE FOLLOWING CRITERIA:

- Score on Midcourse Questionnaire _____% (Attach Answer Sheet)
- Counseling and Clinical Skills Evaluation: Satisfactory Unsatisfactory
- Provision of services (practice): Satisfactory Unsatisfactory

Trainer's Signature _____ Date _____

MIRENA[®]: FREQUENTLY ASKED QUESTIONS²

1. What is Mirena?

- The levonorgestrel-releasing IUD or intrauterine system (LNG IUS), also called Mirena, is a T-shaped plastic device that is inserted into a woman's uterus. The device steadily releases small amounts of levonorgestrel (the progestin widely used in implants, oral contraceptive pills, and vaginal rings) each day into the uterus.
- The LNG-IUD provides several non-contraceptive health benefits, including treatment for long and heavy menstrual periods (see p. xx).
- The LNG-IUD is licensed for 5 years of use (and data shows that it is effective for at least 7 years).

2. How does Mirena work?

The LNG-IUD works more like hormonal methods than like copper IUDs. It works mainly by thickening cervical mucus so that sperm cannot pass through it. It also changes the endometrium and inhibits the survival of sperm, and prevents ovulation in some women.

3. How effective is Mirena and for how long?

The LNG-IUD is *always very effective*—0.1 pregnancies per 100 women in the first year of use (1 per 1,000); and 0.5 per 100 women to 0.8 per 100 women (5 to 8 women per 1,000) by 5 years of use. One study found a pregnancy rate of 1.1 pregnancies per 100 women after seven years of use. The LNG-IUD is effective for at least 5 years.

4. What side effects can Mirena have?

Mirena can cause changes in monthly bleeding, including: absence of any bleeding, lighter bleeding and fewer days of bleeding, irregular bleeding, infrequent bleeding, and prolonged bleeding. It can also cause ovarian cysts.

5. Who can use Mirena? Who should not use it?

Medical eligibility for the LNG-IUD is similar to that of Cu-IUDs. There are additional medical conditions, however, that are not compatible with LNG-IUD use (due to the added hormonal component), such as:

² Adapted from: WHO and JHU/CCP 2006 (draft).

- Birth less than 4 weeks ago
 - Serious heart or blood pressure problems (e.g., deep vein thromboembolism or pulmonary embolism)
 - Current breast cancer
 - Jaundice, viral hepatitis, cirrhosis of the liver, or a liver tumor
6. What are the main similarities between LNG-IUDs and copper-bearing IUDs?
- Effectiveness:** Both types of IUDs are among the most effective contraceptive methods available.
- No protection against STIs:** Neither type of IUD offers any protection against STIs, including HIV/AIDS.

7. What are some differences between LNG-IUDs and copper-bearing IUDs?
- Effective life:** Whereas LNG-IUD is approved for 5 years, the Copper T 380A is approved for 10 years (effective for at least 12).
- Ease of insertion:** LNG-IUDs are generally more difficult to insert than Cu-IUDs. The procedure, which requires a specially trained provider, is more likely to cause pain, faintness, and nausea or vomiting.
- Cost:** The LNG-IUD is more expensive than Cu-IUDs.
- Postpartum use:** Whereas the Cu-IUD can be inserted within 48 hours of birth (by a specially trained provider), the LNG-IUD must not be inserted until 4 weeks postpartum.
- Bleeding patterns and reasons for discontinuation:** The LNG-IUD is likely to decrease the monthly bleeding over time and can cause absence of monthly bleeding, which is among the main reasons LNG-IUD users discontinue the method. Cu-IUD users often have longer and heavier monthly bleeding, bleeding between monthly periods, and more cramps or pain during monthly bleeding, which are among the main reasons they discontinue the method.
- Anemia:** Whereas Cu-IUDs may make contribute to anemia, LNG-IUDs may actually help prevent it.